

# BioDisc<sup>®</sup> BA, BAX, BB, NB

---

## INSTALLATION MANUAL

---

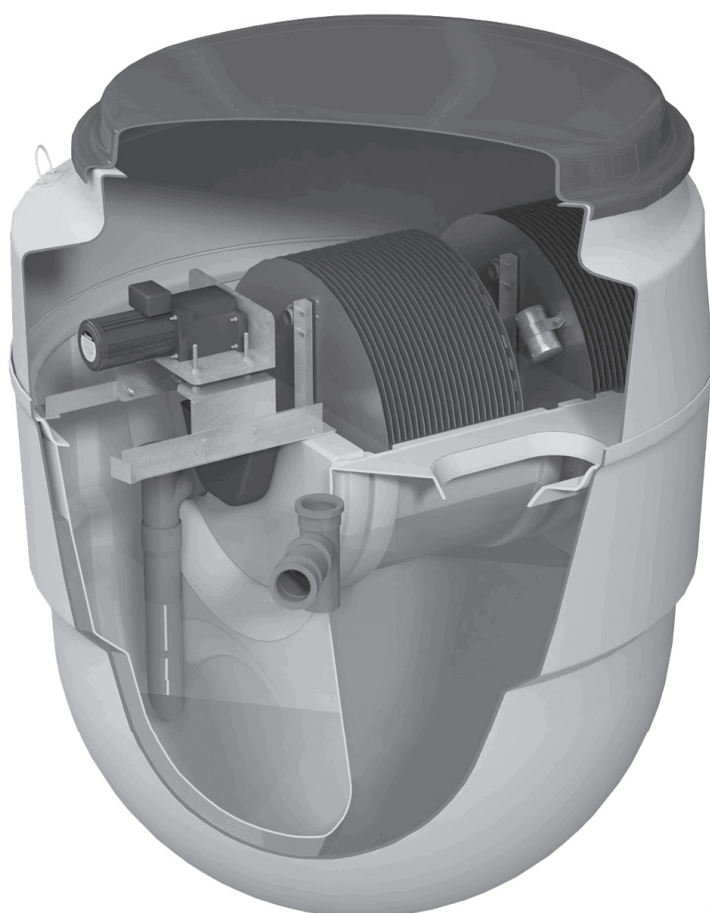

### Important

Once installed, the motor should be left on and running. If there is delayed electrical connection or if there is no power available to operate the unit, then the motor with gearbox must be removed and stored in a dry environment. The motor must not be left non-operational for a period of 7 days or more.

Part Code	Issue	Description	Date
017900	01	Initial Issue	January 2014

# Contents

<b>Health and Safety</b>	<b>Page 3</b>
<b>BioDisc® Checklist</b>	<b>Page 4</b>
<b>Installation</b>	<b>Page 5</b>
<b>Capacitor and Control Panel</b>	<b>Page 8</b>
<b>Start up</b>	<b>Page 11</b>



## HEALTH AND SAFETY

You must read these warnings carefully before installing or using the equipment. Should the equipment be transferred to a new owner, always ensure that all relevant documents are supplied. Observe all hazard labels and take appropriate action to avoid exposure to the risks indicated. Take care to maintain correct posture, particularly when lifting. Use appropriate lifting equipment when necessary.



- Only experienced contractors should carry out installation, following the guidelines.
- The unit should have a Pre-Service Agreement Inspection by an approved engineer.
- A qualified electrician should carry out electrical work.
- Covers must be kept locked.
- Observe all hazard labels and take appropriate action to avoid exposure to the risks indicated.



### CLOTHING

- We recommend the use of a dust mask and gloves when cutting GRP components.
- Any person carrying out maintenance on the equipment should wear suitable protective clothing, including gloves.

### WORKING AREA

- Ensure that the working area is adequately lit.
- Ensure that you are familiar with the safe working areas, accesses and that the area is adequately lit.
- Use only the designated access walkways. Do not walk on the cover or deep well safety mesh(es).
- Keep proper footing and balance at all times. Avoid any sharp edges.



### MAINTENANCE AND INSPECTION PROCEDURES

- Should you wish to inspect the operation of the equipment, please observe all necessary precautions, including those listed below, which apply to maintenance procedures.
- The power supply to the equipment must be isolated at the control panel(s) before lifting the covers.
- If the equipment has to run with the covers off, all care must be taken to avoid contact with moving parts and electrical components or conductors.
- Drive guards must be replaced and secured if removed during maintenance.
- Once power has been isolated, the control panel must be kept locked shut to avoid accidental re-connection whilst work or inspection is being carried out.



### DESLUDGING

- Desludging should be carried out by a licensed waste disposal contractor holding the relevant permits to transport and dispose of sewage sludge.
- The contractor must refer to the desludge instructions in the Operating Handbook, a copy of the instructions is fastened under the covers.

## BioDisc® Checklist

### BA - BB - BAX BioDisc

---

Product Code Example - ,BAUAGA104000K'

1. The unit will be fitted complete with internal pipework and equipment.
2. Inlet pipework will be fitted.
3. Unit supplied strapped to a standard pallet.
4. Unit Overall Heights are as follows;

- 450mm Inlet Invert	=	2160mm
- 750mm Inlet Invert	=	2460mm
- 1250mm Inlet Invert	=	2960mm



### HOLDING DOWN BOLTS

---

1. The Holding Down Bolts pack will be secured to the pallet as shown in the picture.
2. The Holding Down Bolts need to be fitted to the Holding Down Lugs that are fitted to the Tank - 4 Pos. as detailed in the Installation Manual.

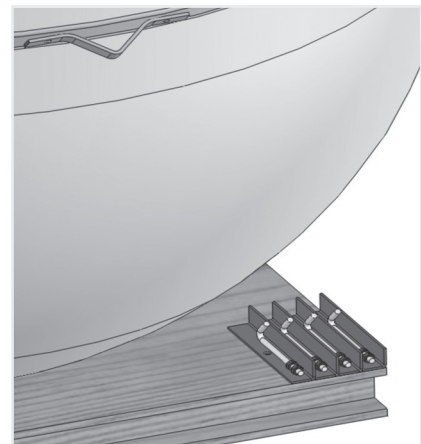

### CONTROL PANEL

---

1. The unit Control Panel will be secured inside the Tank (below the Motor) when delivered.
2. The Control Panel must be removed before the the tank is filled with water during the installation process.

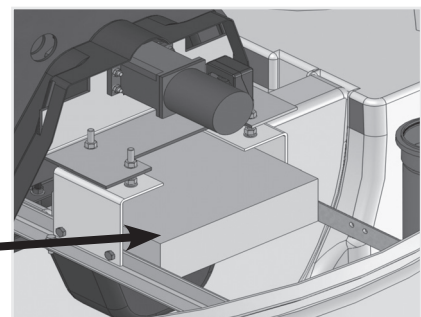

# INSTALLATION

## 1. EXCAVATE A HOLE

Approximate dimensions

Inlet	Depth	Width
450 mm	2000 mm	2145 mm
750 mm	2300 mm	2145 mm
1250 mm	2800 mm	2145 mm

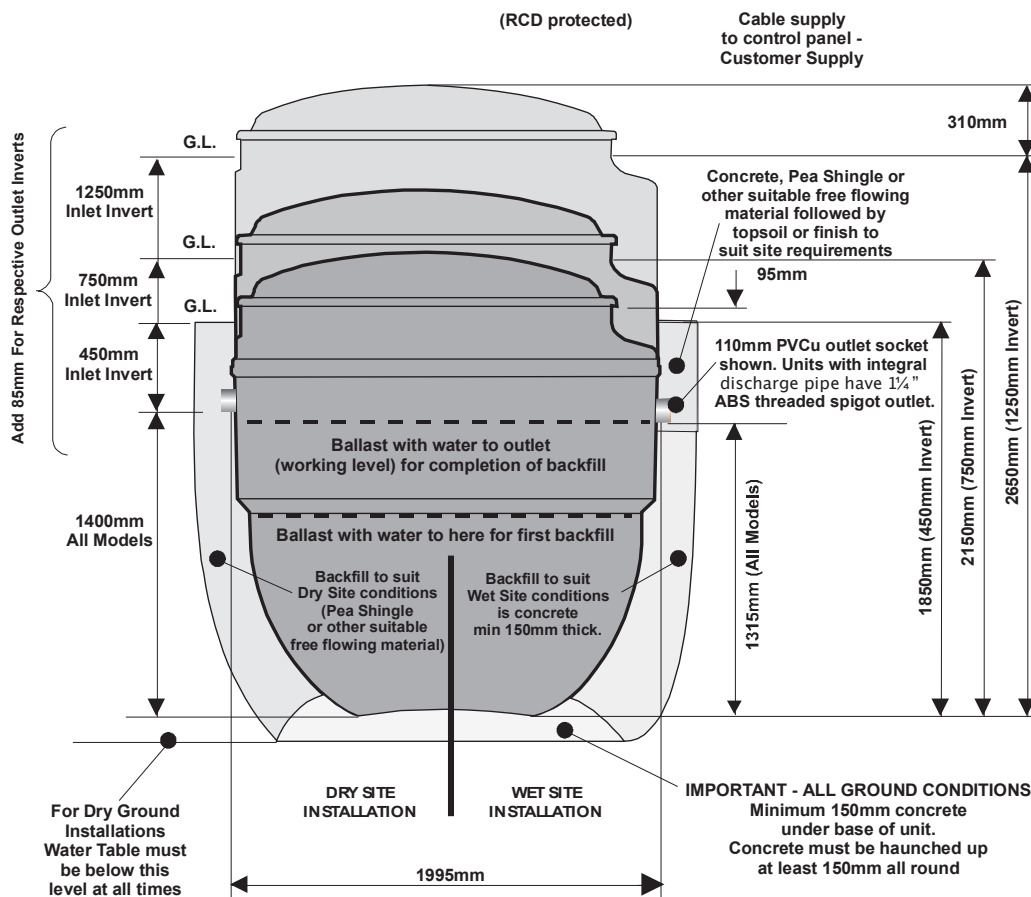

Internal Volumes of Units as an aid to Calculate Materials

① Base to Working Water Level	3.00m <sup>3</sup>
② Water Level to Ground Level	
450mm invert	3.00m <sup>3</sup>
750mm invert	4.75m <sup>3</sup>
1250mm invert	7.50m <sup>3</sup>

Approx. Weights:  
(includes pallet)

	BA	BB	NB
450mm invert	310kg	335kg	360kg
750mm invert	325kg	350kg	375kg
1250mm invert	380kg	405kg	430kg

## 2. LAY CONCRETE BED 150 MM



## 3. LOWER UNIT ONTO CONCRETE

Should not be lifted with any water inside



## 4. BACKFILL AND LEVEL

1. Pour water into primary (inlet) and final (outlet) chamber to 200 mm.
2. Backfill.

Wet site: concrete  
Dry site: Pea shingle

Check that the inlet and outlet orientation is correct and that the unit is level.

The rotor shaft must be level end to end, to within  $\pm 3$ mm, measured at the bearing caps or directly on the shaft. The unit must also be level to within  $\pm 5$ mm from side to side, measured at the GRP platform on either side of the rotor.



**Water levels always in the primary and final chamber 200 mm higher than backfill**

**5. WET SITE: ASSEMBLE THE FOUR ANCHOR BARS**

---

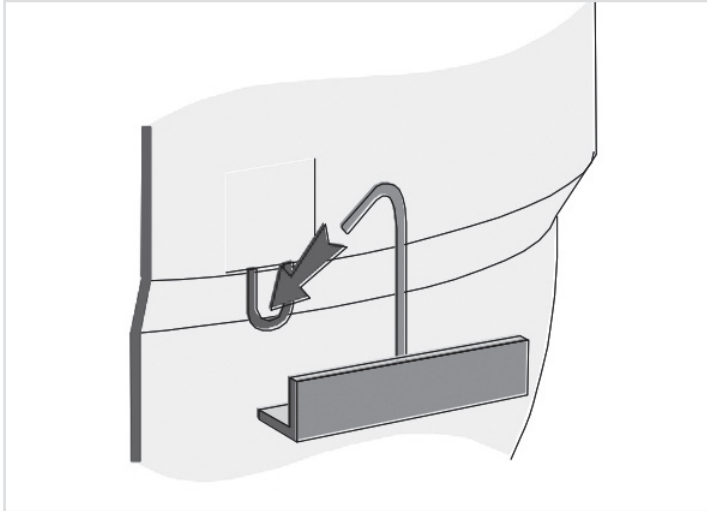

**6. CONNECT INLET AND OUTLET PIPEWORK**

---

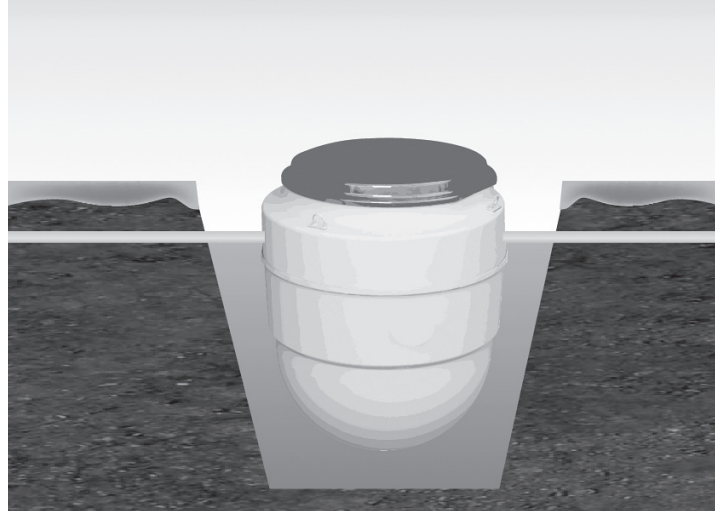

**7. ERECT CONTROL PANEL**

---

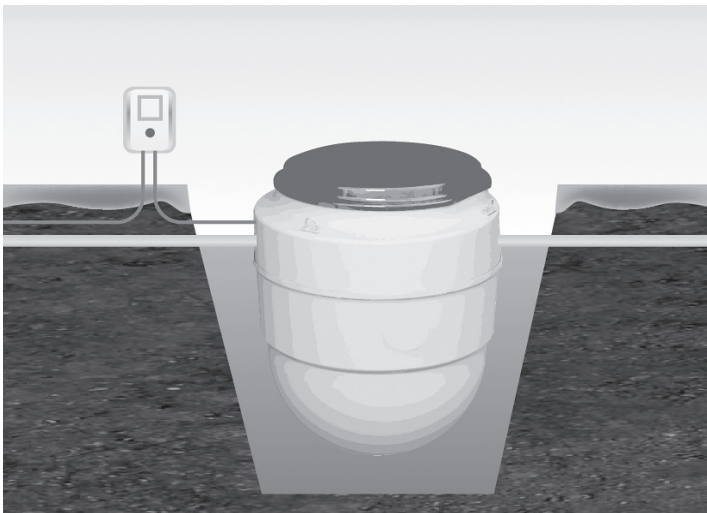

**8. CONTINUE TO BACKFILL**

---

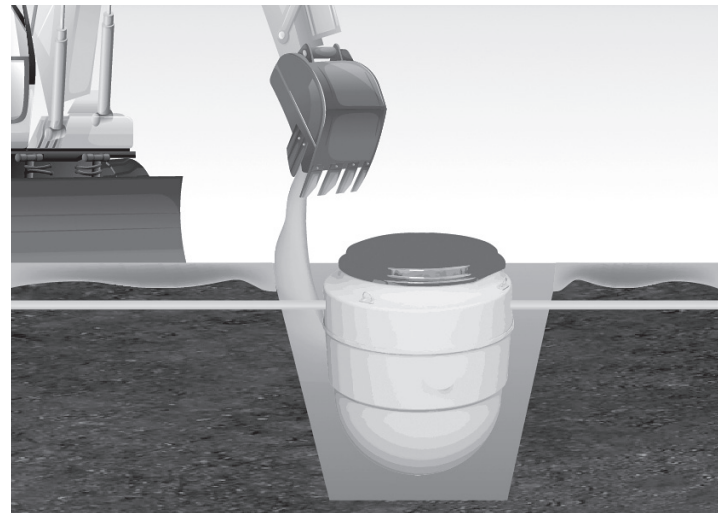

**Finished surface 95 mm lower than lid**

## CAPACITOR AND CONTROL PANEL

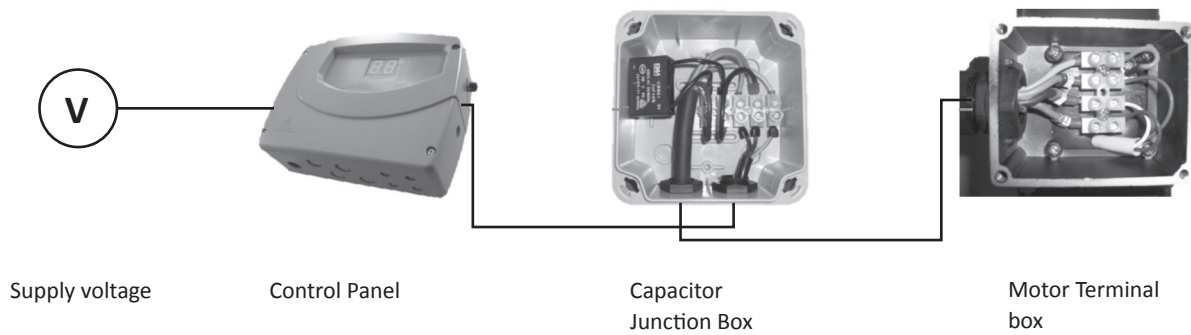

### CONTROL PANEL INSTALLATION

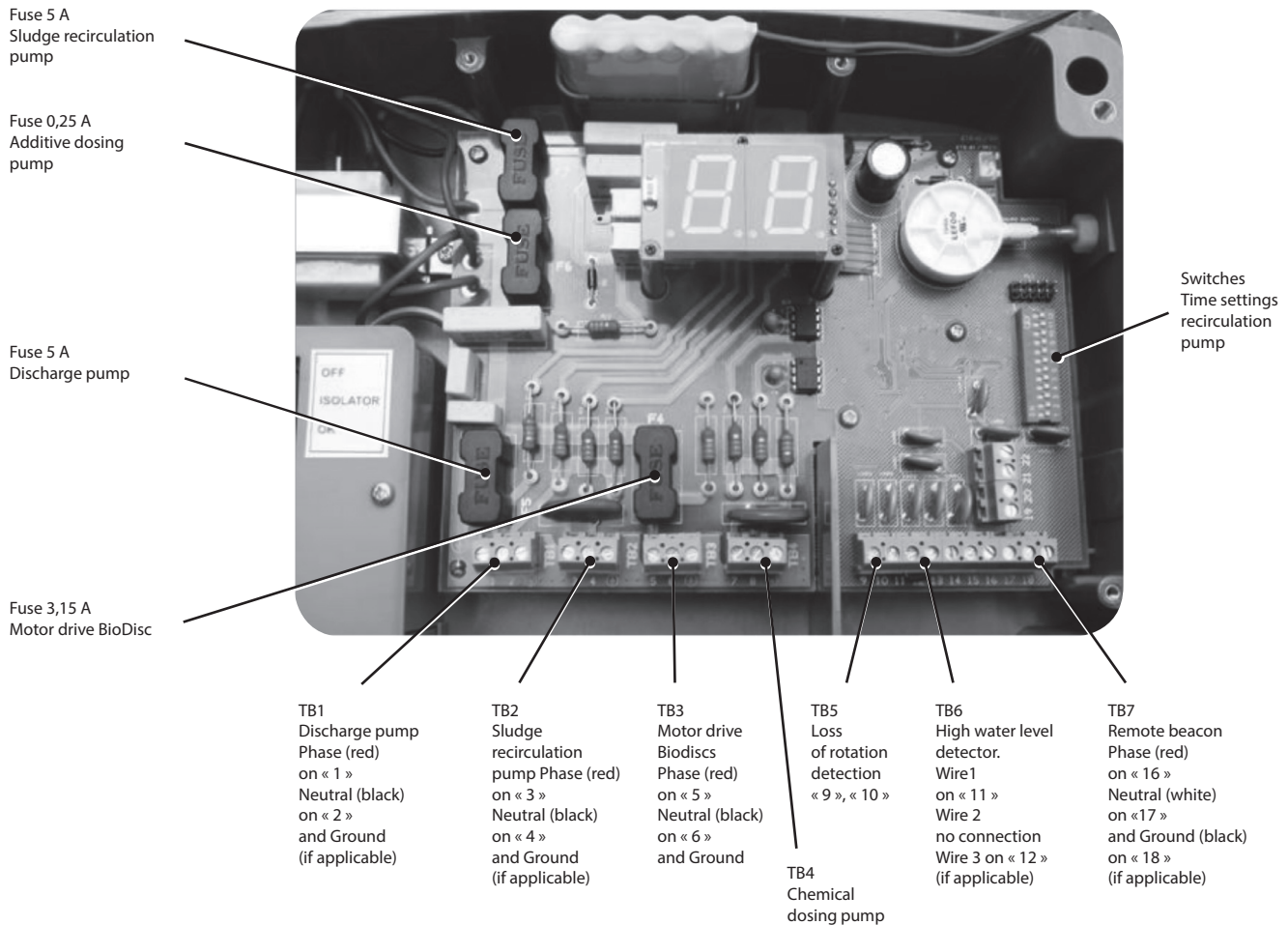



## CONTROL PANEL ENTRY POINTS DEPENDING ON THE EQUIPMENT SUPPLY

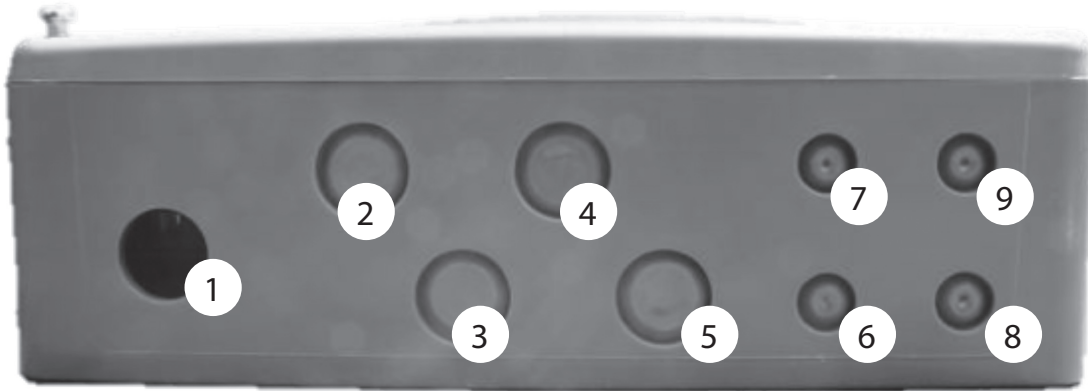

Product	Required Gland	Feed through Gland Hole number	Terminate to connection
Mains power supply	M20	1	
Integral discharge pump power cable	M20	2	1&2
Sludge return pump power cable	M20	3	3&4
Motor power supply cable	M20	4	5&6
Chemical dosing pump power cable	M20	5	7&8
Loss of rotation alarm cable	M12	6	9&10
High level alarm cable	M12	7	11&12
Chemical dosing probe cable	M12	8	13, 14&15
Beacon	M12	9	16, 17&18

		Full Load Current (Amps)			
		BA	BAX	BB	NB
Motor	240 volt single phase	0.52	0.52	0.52	0.52
	415 volt three phase	0.22	0.22	0.22	0.22
Integral discharge pump	240 volt single phase only	2.2	2.2	2.2	N/A
Sludge return pump	240 volt single phase only	N/A	N/A	N/A	2.2

## FAULT CODES AND FUSES

CODE	FAULT CONDITION	FUSE	Amp
F1	No power to the unit	Customer Fuse box	N/A
F2	The blower pressure has failed (not applicable to BioDisc®)	N/A	N/A
F3	The high level alarm has activated (where fitted)	N/A	N/A
F4	The fuse to the motor has failed	F3	3.15
F5	The fuse to the discharge pump has failed (where fitted)	F1	5.0
F6	The fuse to the chemical dosing pump has failed (where fitted)	F4	0.25
F7	The fuse to the recirculation pump has failed (where fitted)	F2	5.0
F8	The loss of rotation alarm has been activated	N/A	N/A
--	The unit has had a fault which has now corrected itself (Flashing left and right - Battery charging Flashing left only - Battery charged)	N/A	N/A

All fuses are Time Lag HBC 20mm type

## RUN AND PAUSE TIME SETTING

### Chemical Dosing Pump Pause Time

Switch 1	Switch 2	
Off	Off	48 minutes (default BA)
Off	On	24 minutes (default BB)
On	Off	12 minutes
On	On	6 minutes

### Chemical Dosing Pump On Time

Switch 3	Switch 4	
Off	Off	4 seconds
Off	On	3 seconds
On	Off	2 seconds (default)
On	On	1 second

### Sludge Return Pump Pause Time

Switch 5	Switch 6	
Off	Off	12 hours
Off	On	6 hours
On	Off	2 hours (default)
On	On	1 hour

### Sludge Return Pump On Time

Switch 7	Switch 8	
Off	Off	30 seconds
Off	On	20 seconds (default)
On	Off	10 seconds
On	On	5 seconds

## START UP

---

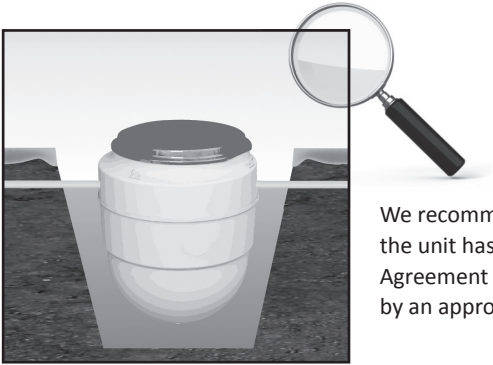

We recommend that the unit has a Pre-Service Agreement Inspection by an approved engineer.

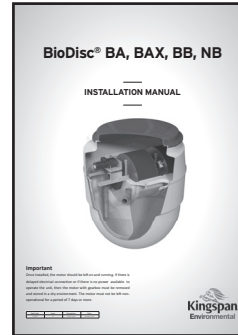

Refer to the Owner's Handbook for details of the Start Up Procedure.



Once the unit has been installed it should be left filled with water.

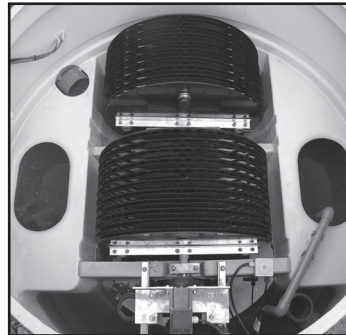

**DO NOT CONNECT UNITS WITH INTEGRAL PUMPS TO A SEWAGE SUPPLY, WITHOUT ENSURING THAT THE ELECTRICITY IS CONNECTED AND THAT THE UNIT IS OPERATIONAL**



**Kingspan Environmental Ltd**

180 Gilford Road  
BT635LF  
Portadown  
United Kingdom

Tel: +44 (0) 28 3836 4400  
Fax: +44 (0) 28 3836 4445  
[www.kingspanenviro.com](http://www.kingspanenviro.com)

---