



6 panel SF55s with fixed frame angled glazing above | RAL 7012 Basalt grey | 3-left, 3-right | flush track

bifold doors

aluminium

Innovative, award-winning bifold doors



SUNFLEX™

Aluminium folding door systems

Aluminium's incredible strength and lightweight construction make it a highly versatile material. Our range of precision engineered SUNFLEX aluminium bifold doors offer a contemporary, modern look and provide a maintenance free solution. With minimal sight lines, more than 200 different colours and double or triple glazing, this range will meet the demands of your project.



For over thirty years, SUNFLEX has led the global market in the design, development and manufacture of bifold doors. Today they are widely regarded as the most advanced systems available, with each product handmade to the highest quality and featuring a wide range of unique features and system options.

The SUNFLEX range of aluminium bifold doors features:

- SF55i – designed and manufactured for standard configurations of doors making it ideal for urban or suburban extensions or renovation projects
- SF55s – an award-winning bifold door designed for more complex configurations including those featuring moveable corner posts or for projects in more rural or exposed locations
- SF55v – a truly innovative adaptation of the SF55i that allows the doors to be open from and be stacked to the same end of the aperture
- SF75 – an industry-leader for thermal and weather performance that can achieve an incredibly low U-value from just 0.9W/m²K, ideal for ultra-thermally efficient new-builds and renovations

In addition the SF55s and SF75 are also available with internal timber cladding, providing the natural beauty of wood on the inside face of the door with maintenance free aluminium on the outside. Please request a copy of our composite bifold door brochure for more information.



3-panel SF55s | RAL 7013 Brown Grey | 3-left | Low-threshold track



See our bifold doors at

- ▶ The Building Centre in Central London
- ▶ Our Comprehensive Showroom in Norwich
- ▶ Exhibitions across the country

4 panel SF55s | RAL 7016 Anthracite grey | 3-left, 1-right | weathered track

SUNFLEX SF55i

Innovative aluminium bifold door



Designed with narrow 55mm frame depths and contemporary square-edge profile the SUNFLEX SF55i is ideally suited for standard bifold door configurations that slide to one end or meet in the middle and slide to either side.

The SF55i shares the same quality and effortless usability of all SUNFLEX bifold doors and, like the rest of the SUNFLEX range, carries the prestigious BSI Kitemark™ quality assurance and Secured by Design security awards.

Available with double glazing as standard (the SF75 offers industry-leading thermal performance if triple glazing is required), the SF55i can be designed to be fold to the left or right, open inwards or outwards with panels up to 3m high and up to 1.1m wide.

Each set of SF55i doors is handmade in-house to your exact requirements by our own experienced fabricators, providing you with complete peace of mind, whatever the size and scale of your project.

SF55i Track options

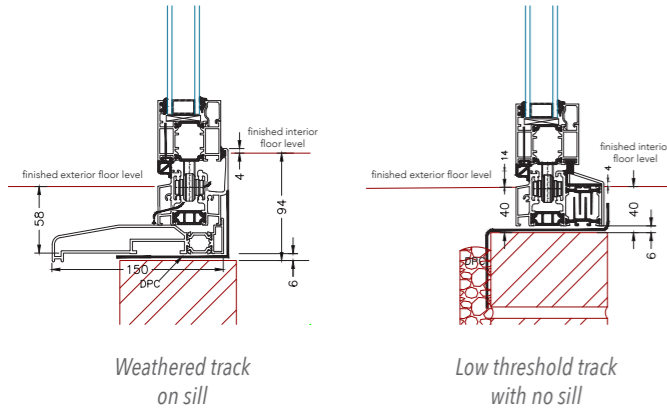

SF55i U-Values

U-value of glass (Wm ² /K)	Overall system U-value (Wm ² /K)
0.7 Triple glazed	1.3
1.0 Double glazed	1.6

SF55i KEY FEATURES

- Unrivalled quality**
 Designed with more than 30 years of folding door experience to meet prestigious BSI Kitemark™ standards.
- Stunning appearance**
 Slender 55mm frame depths, narrow 117mm sightlines, panels up to 1,100mm wide and up to 3,000mm high and a choice of either low-threshold or fully weathered tracks.
- Complete usability**
 Designed to be used, the SF55i has ultra-smooth, effortless operation on doors that can open inwards or outwards and that include exclusive panel catch technology.
- Security as standard**
 Manufactured with multi-point locking to meet the requirements of PAS 24:2016 and Secured by Design's police preferred specification for security.
- Severe weather rating**
 Independently tested to severe weather rating standards to achieve 600Pa water tightness and 300Pa air permeability.

SF55v versifold door

With its ability to open and stack to either end the SF55v provides a versatile alternative to standard bifold door configurations.



"We absolutely love our SUNFLEX bifolds, they look amazing, are so easy to use and being able to open them up makes our kitchen feel so much bigger"

Mr & Mr Hall, North London

SUNFLEX SF55s



Award-winning aluminium bifold door

The innovative SUNFLEX SF55s is amongst the most advanced aluminium bifold doors on the market and perfect for more complex configurations that include moveable corner posts or for extreme panel sizes.

Manufactured from the same aluminium frame as the SF55i, the SF55s features incredibly slim 55mm frame depths, minimal 115mm sightlines and an advanced triple-rebated EPDM rubber gaskets for superior weather performance that make it ideal for rural and exposed locations.

Like all of the SUNFLEX bifold doors, the SF55s has been awarded the BSI Kitemark™ quality assurance accreditation and holds the Secured by Design awards for police preferred security specification.

Available with either double or triple glazing, the SF55s can be designed and installed in an almost limitless range of configurations, enabling you to create your dream home without compromising on design, performance or everyday usability.

SF55s Track options

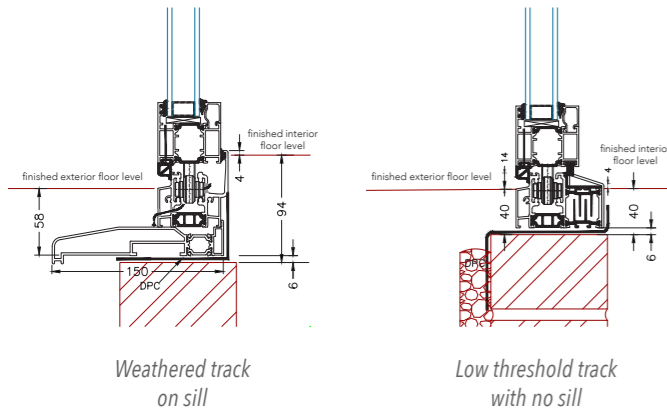

SF55s U-Values

U-value of glass (Wm ² /K)		Overall system U-value (Wm ² /K)
0.7	Triple glazed	1.3
1.0	Double glazed	1.6

SF55s KEY FEATURES

- Award-winning bifold doors**
 Named Build It magazine's 'Best Glazed Doors'.
- Capable of complex configurations**
 Achieves even the most complex of configurations, including moveable corner posts to create stunning uninterrupted open corners.
- Stunning appearance**
 Ultra-slim 115mm sightlines and narrow 55mm frame depths with panels up to 1,200mm wide and up to 3,500mm high and a choice of either low-threshold or fully weathered tracks.
- The most weathertight bifold doors available**
 Independently tested to industry leading weather performance standards of 900Pa water tightness and 600Pa air permeability thanks to continuous interlocking triple rebated gaskets.
- Innovative features**
 Unique panel catch holds first door in place whilst exclusive stacking clip technology secures system when doors are fully opened. Unique part-vent position allows for doors to provide ventilation without having to be opened.
- Unrivalled quality**
 Designed with more than 30 years of folding door experience to meet prestigious BSI Kitemark™ standards.
- Security as standard**
 Manufactured with multi-point locking to meet the requirements of PAS 24:2016 and Secured by Design's police preferred specification for security.



SF55c composite bifold door

Also available with internal timber cladding to provide the natural beauty of wood on the inside face of the doors.

"Opening up the entire corner of the extension with our bifold doors is easily my favourite bit of the entire project and it is so easy to do. The view into the garden and over the fields is incredible"

Mrs Keane, Suffolk

SUNFLEX SF75

Ultra thermally efficient aluminium bifold doors with industry leading weather protection

The SUNFLEX SF75 bifold doors have been specifically designed to offer the best in thermal efficiency – an extremely low U-Value, eco-friendly folding door system. This market leading system provides the lowest in CO2 emissions associated with reduced energy consumption and considerable savings in heating bills.

Designed for efficiency – a unique bifold door system, specifically designed to accommodate a triple glazed sealed unit. The advanced engineering and clever technology enables the system to perform to the highest levels of thermal efficiency, as well as maintaining the stunning visual appearance, slim sight lines and configuration options of the award-winning SF55s. Unlike competitors' systems that use the same profile to accommodate double glazing and triple glazing, the SF75 has been designed and developed specifically to offer the ultimate levels of performance and the flexibility for everyday use.

SF75 Track options

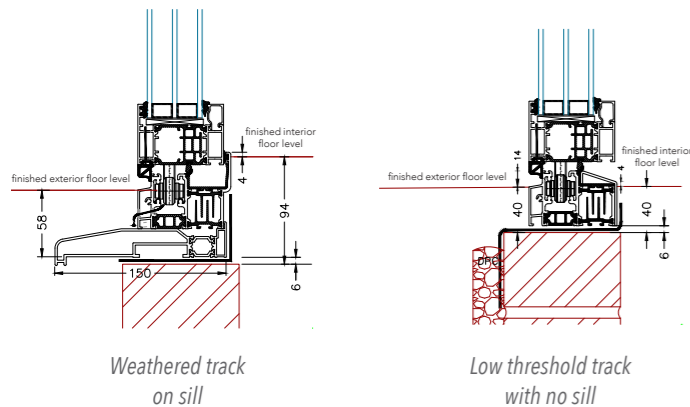

SF75 U-Values

U-value of glass (Wm ² /K)	Overall system U-value (Wm ² /K)
0.6 Triple glazed	1.0
0.5 Triple glazed	0.9

SF75 KEY FEATURES

- Unrivalled performance**
 An industry leading combination of advanced thermal performance (U-value from 0.9W/m²K) with unrivalled weather performance (900Pa water tightness and 600Pa air permeability) to severe weather rating standards.
- Stunning appearance**
 Ultra-slim 115mm sightlines and 75mm frame depths designed to accommodate a triple-glazed unit. Panels sizes up to 1,200mm wide and up to 3,500mm high with a choice of either low-threshold or fully weathered tracks. Can be used to create open corners with integrated moveable corner post.
- Security as standard**
 Manufactured with multi-point locking to meet the requirements of PAS 24:2016 and Secured by Design's police preferred specification for security.
- Innovative features**
 Unique panel catch holds first door in place whilst exclusive stacking clip technology secures system when doors are fully opened. Unique part-vent position allows for doors to provide ventilation without having to be opened.
- Unrivalled quality**
 Designed with more than 30 years of folding door experience to meet prestigious BSI Kitemark™ standards.

SF55c composite bifold door

Also available with internal timber cladding to provide the natural beauty of wood on the inside face of the doors.

"When we were choosing doors for our home the SUNFLEX SF75 was the only system we came cross that was specifically designed for triple glazing which was crucial for our eco-build project"

Mr Hannant, Norfolk





Finger safe gaskets

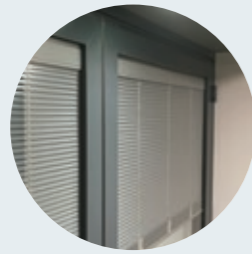

Integrated Venetian blinds



Flush and lever handles



Panel catch



Unique stacking clip (SF55s & SF75 only)



Pull handle

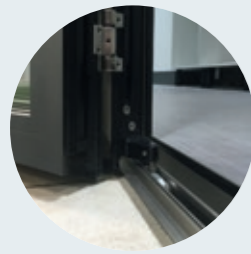

Weathered track

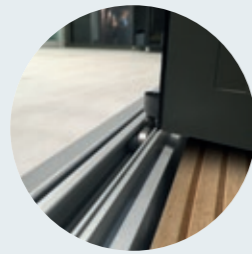

Low threshold track

A unique range of custom made features, options and finishes

There are over 200 RAL colours to choose from, a dual colour option giving different colours to the inside and outside is available as an additional extra.

We have chosen the most popular colours as stocked finishes for each system. For the SF55i you can choose Graphite Black RAL 9011 matt, Slate Grey RAL 7015 matt or Anthracite Grey RAL 7016 matt as standard colours. For the SF55s and SF75 the standard colours are Silver Anodised EVI, Anthracite Grey RAL 7016 semi-gloss, Grey Aluminium RAL 9007 semi-gloss, White Aluminium RAL 9006 semi-gloss or Traffic White RAL 9016 semi-gloss.

There is the option to have different colours on the interior and exterior sides of the doors, which is perfect if you are trying to match interior décor or exterior hardware. Handles and hinges can also be colour coded to match your choice of door colour, as well as the ever-popular choice of stainless steel door furniture.



6 panel SF55s | Dual colour | 3-left, 3-right | flush track

Complete glazing solutions, whatever your project...

Award-winning bifold doors, sliding doors and glazing solutions - all made to fit your home perfectly.

Transforming your home needs an experienced and safe pair of hands, so choosing the right company to work with is important. At IDSystems, we're the market leader in providing multi-award winning glazing solutions for all types of projects - extensions, renovations, self-builds and complete new homes. We guarantee the highest standards of advice, build quality, design and bespoke installation for your complete peace of mind. As a family business founded in 2000, we've built an outstanding reputation for quality, service, expertise and some of the most exciting and innovative designs. From your very first contact with us, you'll know that you're dealing with an industry leader. From our initial designs and technical advice to liaison with architects and builders, creating working CAD drawings and the logistics of final installation, our own staff will be with you every step of the way.





bifold doors



sliding doors



slide & turn doors



windows & doors

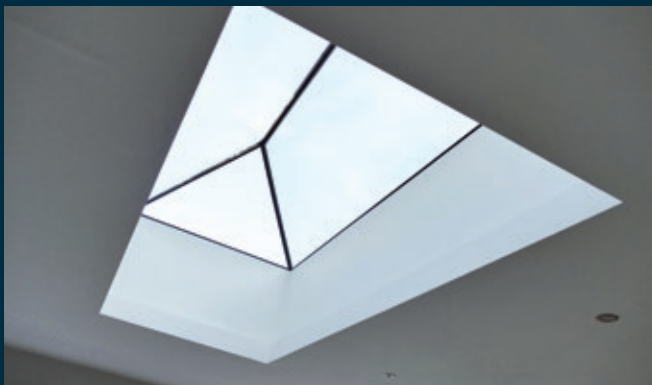

glass roofs

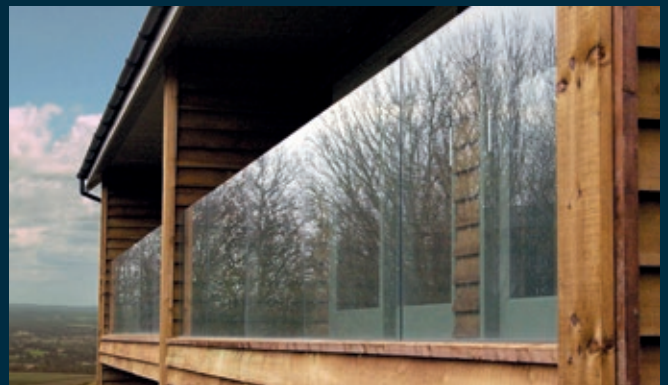

glass balustrades



t 01603 408804 f 01603 258648 e info@idsystems.co.uk

B2 Rhombus Park Diamond Road Norwich NR6 6NN

www.idsystems.co.uk/bifold-doors

See our **bifold doors** at

- ▶ **The Building Centre** in Central London
- ▶ **Our Comprehensive Showroom** in Norwich
- ▶ **Exhibitions** across the country

