

Typical Elevation
Scale 1:20

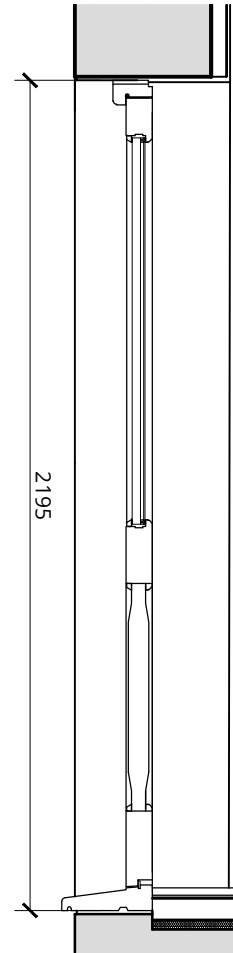

Typical Section - Door
Scale 1:20

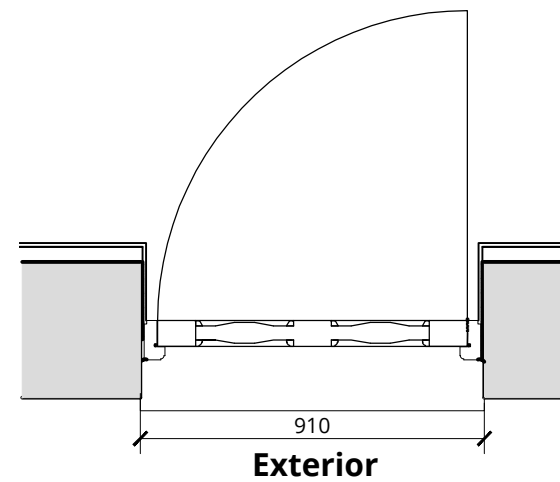

Typical Plan
Scale 1:20

**External Door
ELG-D08**

Existing timber framed doors to be replaced with new four panel timber framed door with upper double glazed panels. New door to fit within existing opening. All profiles and timber mouldings to match existing. External glazing plane to be security rated glass.

Rev.	Description	Date	Rev.	Description	Date	Rev.	Description	Date
0	Discharge of Condition	27.11.2020						