

Typical Elevation
Scale 1:20

Typical Section
Scale 1:20

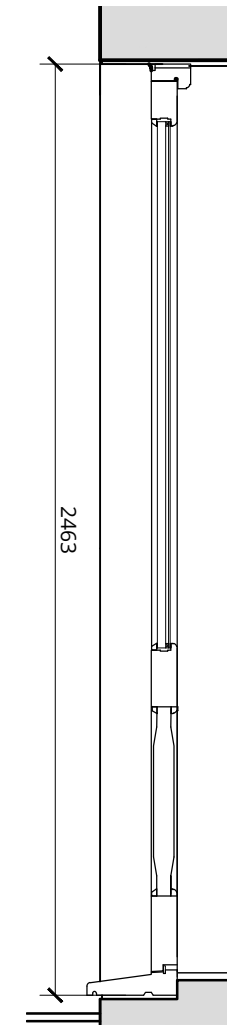
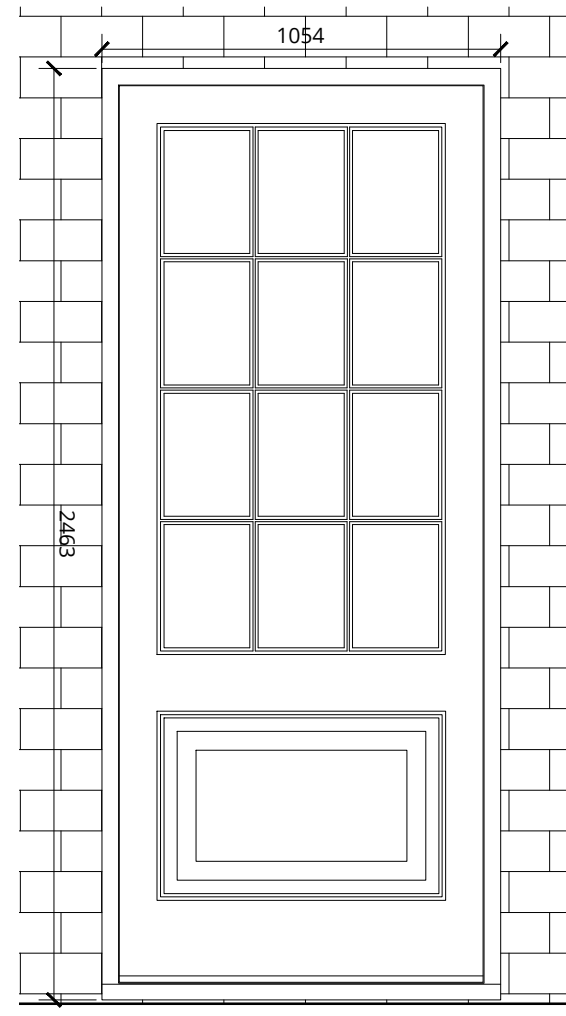

Typical Elevation
Scale 1:20

Typical Section
Scale 1:20

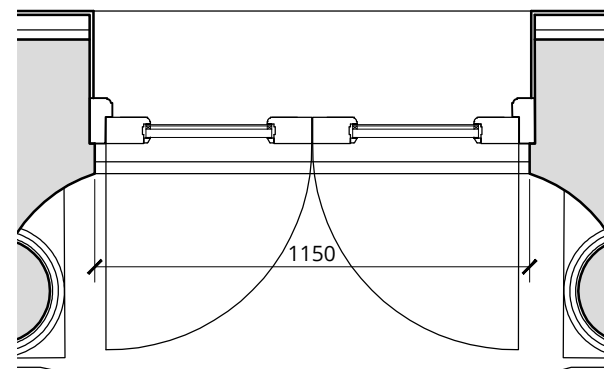

Typical Plan
Scale 1:20

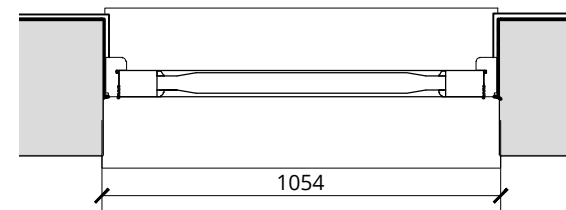

Typical Plan
Scale 1:20

External Door E2-D01

Existing timber framed doors to be replaced with new timber framed double glazed doors in a style to match existing. New door to fit within existing opening. All profiles and timber mouldings to match existing. External glazing pane to be security rated glass.

External Door E5-D03 & E5-D02

Existing windows to be removed and sill lowered new timber framed paneled and double glazed doors to be installed. New door to match the width of existing window. All profiles and timber mouldings to match existing found elsewhere. External glazing pane to be security rated glass.

Rev.	Description	Date	Rev.	Description	Date	Rev.	Description	Date
0	Discharge of Condition	27.11.2020						

