

Solid Oak ledged door

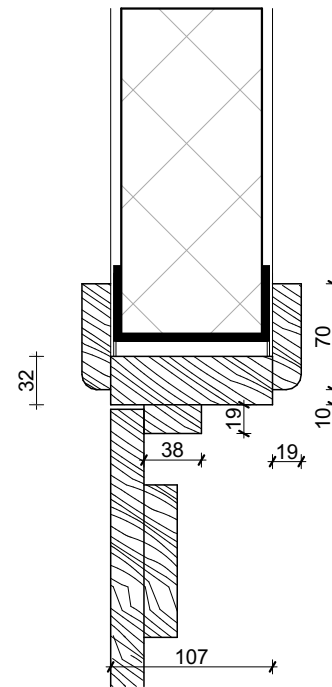
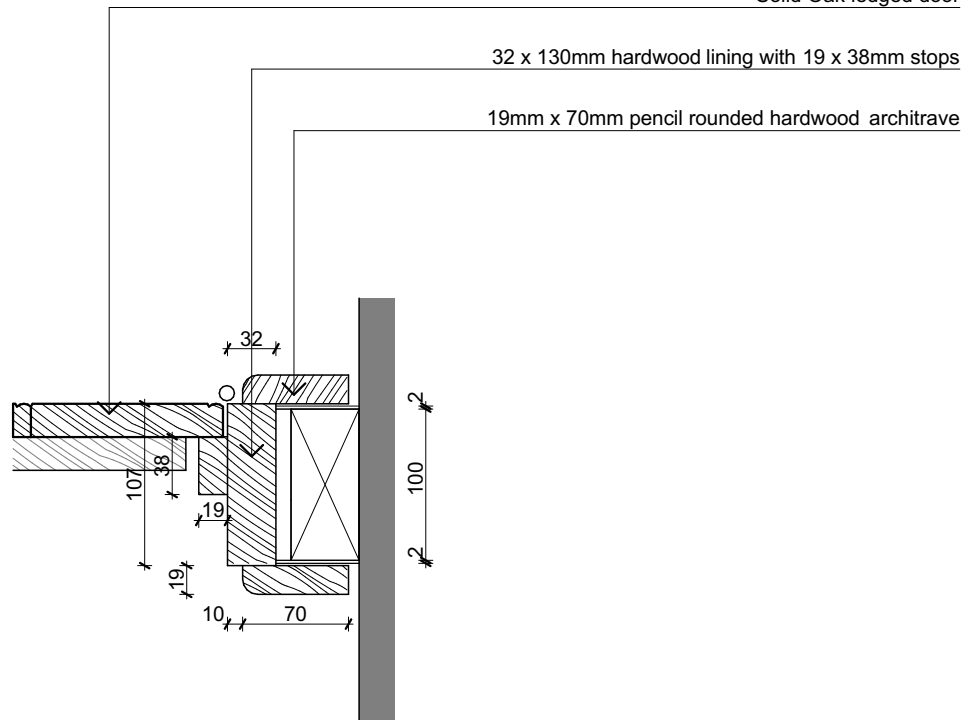

This scheme may be subject to Town Planning and other necessary consents. Ensure Building Control are notified 48 hours in advance of building works starting on site. Refer / comply with all approvals and associated conditions.

Dimensions, areas and levels where given are only approximate and subject to site survey. All dimensions are to be checked on site. Any discrepancies or variations are to be reported to the Architect before work commences. Figured dimensions only are to be taken from this drawing.

This drawing is to be read in conjunction with all relevant consultants and / or specialists drawings and specifications and any discrepancies or variations are to be reported to the Architect before affected work commences.

This drawing is COPYRIGHT

0	1	2	3	4	5	6
0	1	2	3	4	5	6



REPLACEMENT SOLID OAK FOUR LEDGED DOOR



SOLID OAK FULL HEIGHT GLAZED DOOR  
(to study and study lobby)



**Ploice Design Co Ltd**  
Architects & Technologists

Woodbridge | Southwold  
01394 610844 | 01502 722426  
info@ploice.org.uk  
www.ploicemaking.net

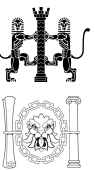

Planning | Landscape | Architecture | Interiors | Cost | Environment

Job Title  
**GOSBECK HOUSE**  
**HELMINGHAM ROAD**  
**GOSBECK, IP6 9RZ**

Drawing Name  
**INTERNAL DOOR DETAILS**

Status  
**PLANNING**

Drawing Scale @ A4	Drawn By	Checked
<b>1:5</b>	<b>GR</b>	<b>CG</b>

Job Number	Drg No	Revision
<b>PL555</b>	<b>A02-15</b>	