

**CDM 2015 RESIDUAL RISKS**

1. Deep excavation required for soakaway.
2. Access to soakaway for maintenance purposes by trained and competent persons only.
3. Density of chalk unknown. Further investigation required or soakaway to be adequately positioned. Refer to Note S2.

The above residual risks are for non-standard hazards. It is assumed that a competent contractor familiar with the construction of this type of work will be appointed who will be aware of the standard hazards.

DO NOT SCALE THIS DRAWING. ALL SETTING OUT TO ARCHITECT'S DETAILS AND DRAWINGS

THIS DRAWING IS TO BE READ IN CONJUNCTION WITH ALL OTHER RELEVANT DRAWING ISSUES AND THE SPECIFICATION.

**Notes:**

- G1. All building materials, components and workmanship to comply with the appropriate public health acts, building regulations, british standards and codes of practice and the appropriate manufacturer's recommendations.
- G2. For all specialist work see relevant drawings.
- G3. Any discrepancies, errors or omissions to be reported to the project co-ordinator for further instructions before commencement of works.
- G4. The Engineer is not responsible for dimensions, except where shown on his drawings. All setting out information, dimensions, etc, shall be calculated from the Architect's drawings.
- S1. Soakaway has been designed based on a maximum drained area of 227m<sup>2</sup>.
- S2. Soakaway is to be positioned at least 5m from existing or proposed buildings or roads. If strata is deemed to be 'low density chalk' or density is unknown, then soakaway is to be positioned at least 10m from existing or proposed buildings or roads.
- S3. Design of external works and below ground drainage network is by others.

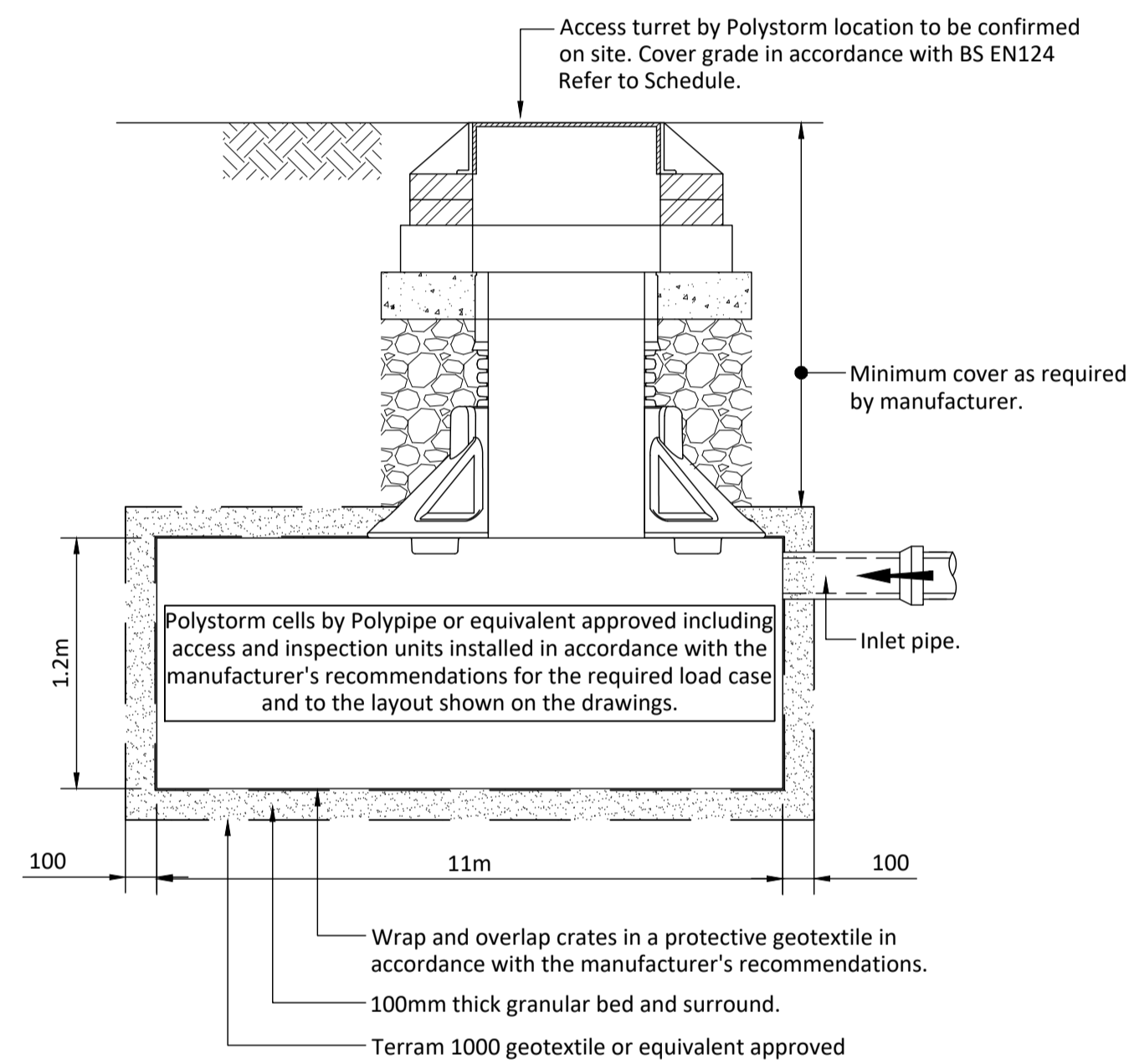

**Typical Geo-Cellular Soakaway Detail**

Soakaway Dimensions: 11m x 2m x 1.2m effective depth.  
NTS

Rev	Amendment	Drn	Chk	Date
PO1	Preliminary issue.	JEM	MIF	09.03.21

**considine**  
civil + structural engineers  
25 Hollingworth Court, Turkey Mill  
Ashford Road, Maidstone, Kent ME14 5PP  
t: 01622 919918 e: info@considine.co.uk  
www.considine.co.uk

Client:  
**MR H KENNEDY**

Project:  
**18A SOMERSET ROAD  
WALMER  
CT14 7TD**

Drawing Title:  
**SOAKAWAY CONSTRUCTION DETAILS**

considine ref	drawn by	date	drawing scales	original paper size
4269	JEM	MAR'21	NOT TO SCALE	A1

drawing reference :	originator	volume	level	type	role	number
4269 - CON - 00 - XX - DR - C - 1530						

status :	status description :
SO	SUITABLE FOR INFORMATION
revision :	revision status :
PO1	PRELIMINARY

This document is © Considine Limited