

Horizontal Section  
1:2

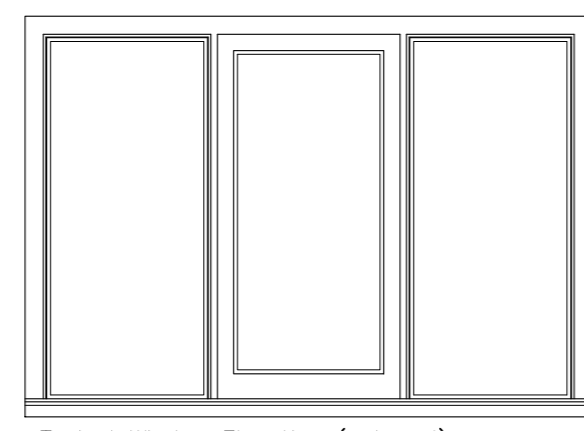

Typical Window Elevation (external)  
1:20

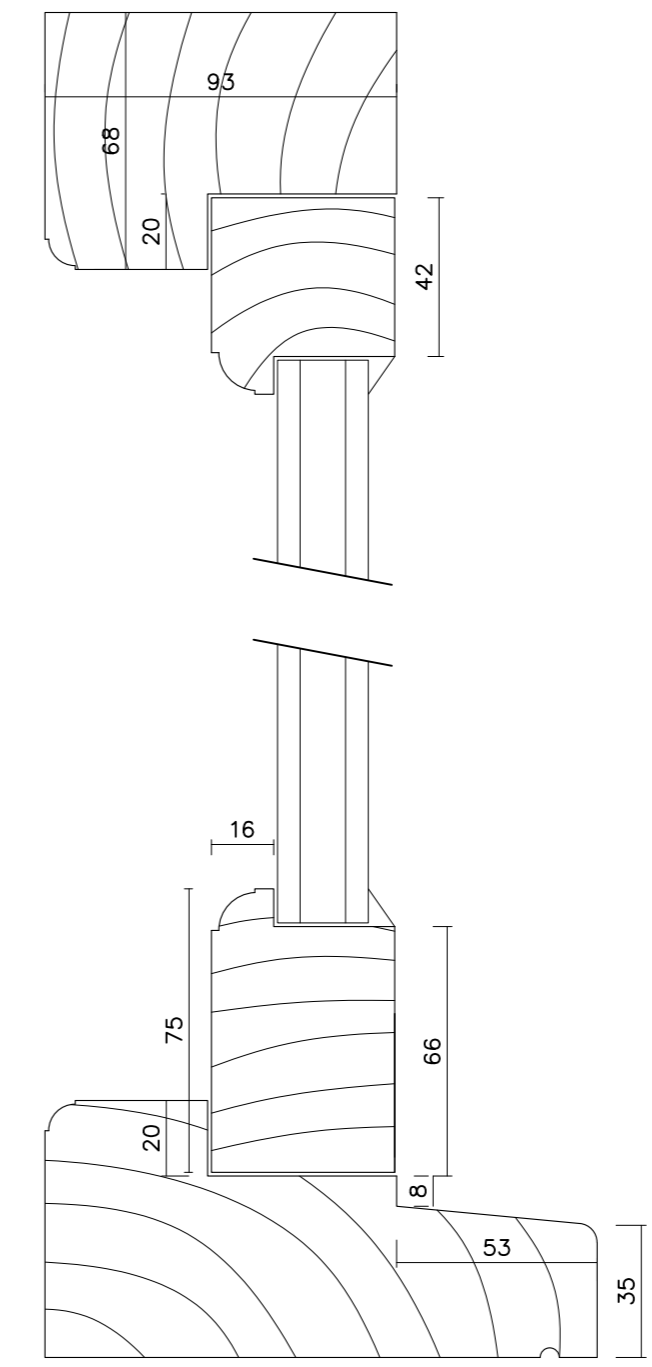

Vertical Section  
1:2

revision	description	date
----------	-------------	------

Client:	Ampton Estate		
Job Title:	11-14 Ampton		
Drawing Title:	Window Details		
Scale:	1:20 1:2	Drawn By:	ET
	A2	Date:	Feb 2022
Job Number:	6661.4	Drawing Number:	02
		Status:	Planning

**whitworth**

Chartered Architects & Chartered Building Surveyors  
Unit 12 Park Farm, Fornham St Genevieve, Bury St Edmunds, IP28 6TS  
01284 760421 info@whitworth.co.uk www.whitworth.co.uk

NOTE:  
Do not scale from this drawing except for the purposes of planning. Confirm all dimensions on site. Refer any discrepancies to the Architect before work is put in hand. Read this drawing in conjunction with the relevant sections of the specification, schedule of works and other drawings.

This drawing is copyright of whitworth.