

Notes:
 - Do not scale from this drawing
 - All dimensions are to be checked on site prior to construction
 - Dimensions marked with an asterisk thus * are open site dimensions to be confirmed on site.
 - Should any discrepancy be found with this drawing please report to this office immediately.
 - This plan and its content is copyright of Smith&Garratt - © Smith&Garratt 2021. All rights reserved.
 - Any redistribution or reproduction of part or all of the contents in any form is prohibited.

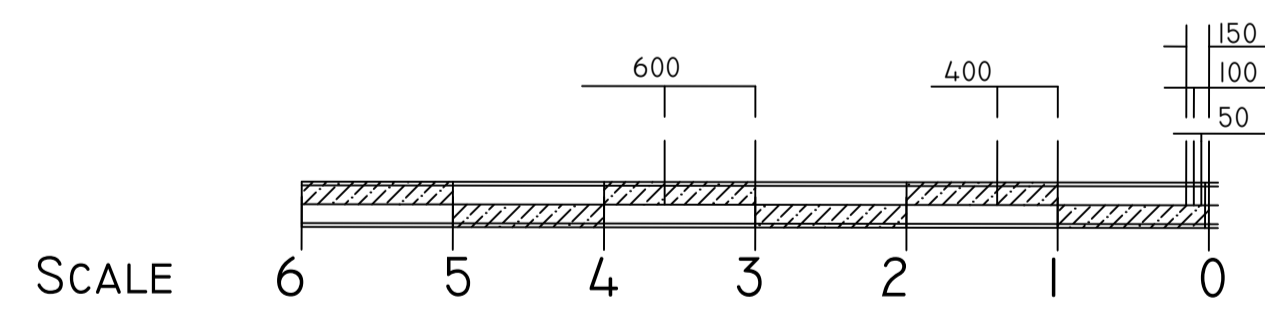

Rev | Date | Note | By | Ckx

Status **PLANNING**

Project **Watkinson**

Client **Watkinson**

Drawing **Proposed North Elevation**

Drawn by **Rachel Reeves**

Scale **1:50 @A1**

Date **11 Apr 2022**

Drawing Number **WAT03.1**

Rev **A**

