

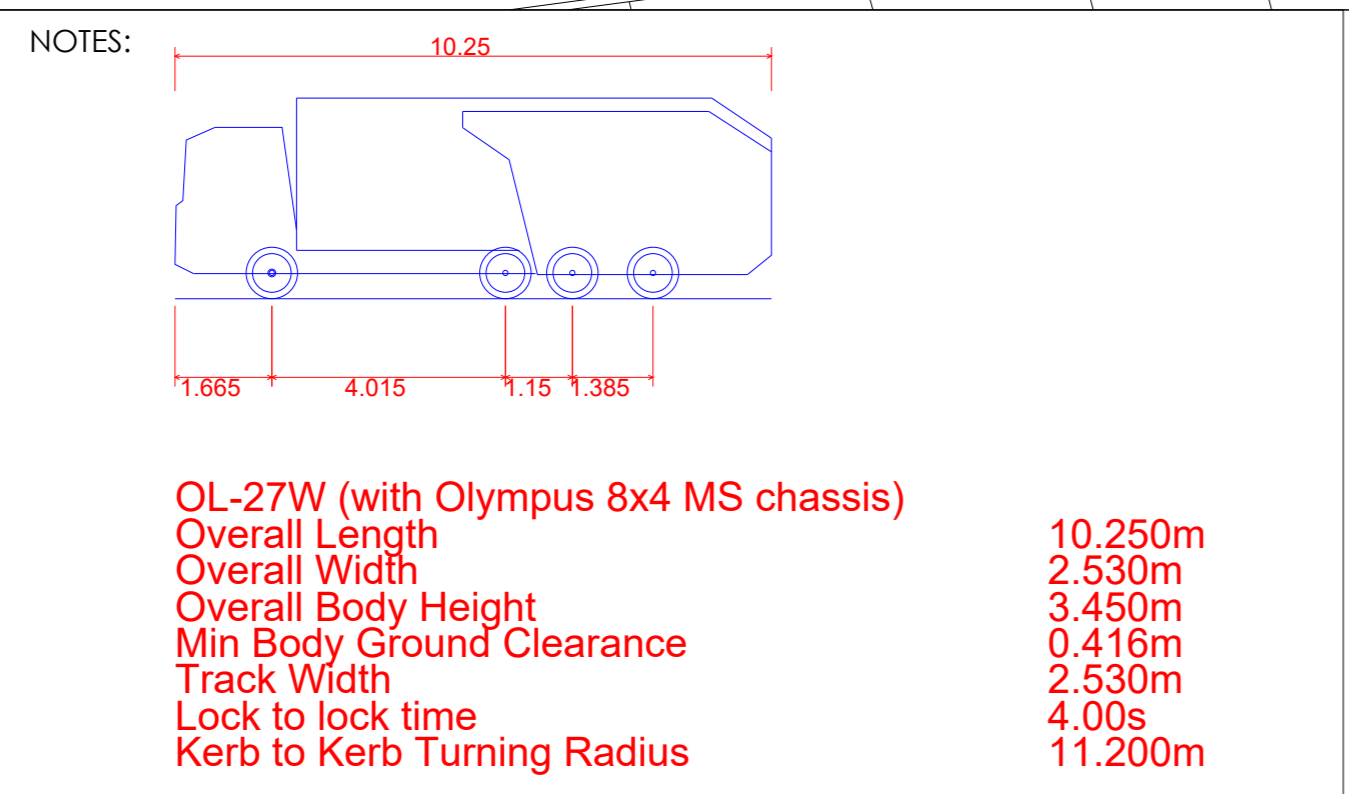

CLIENT:
 Linden Homes Limited
 Ashurst, Southgate Park
 Bakewell Road
 Orton Southgate
 Peterborough
 PE2 6YS

**Linden
 HOMES**

Tel: 01733 396600
 Fax: 01733 396669



REV	DESCRIPTION	DATE

STATUS:
 Planning Purposes Only

SCALE: 1:500 @ A0
 DATE: March 2022
 DRAWN: IDL

TITLE:
 Refuse Tracking

PROJECT:
 Mepal Road, Sutton

DRG. No:
 985-00-20 Rev A

iDLTD
 INFRASTRUCTURE DESIGN LIMITED

33 The Point
 Market Harborough
 Leicestershire LE16 7QU
 Tel: 01858 411570 Fax: 01858 411571