

Left Turn - Road 12 to Road 10

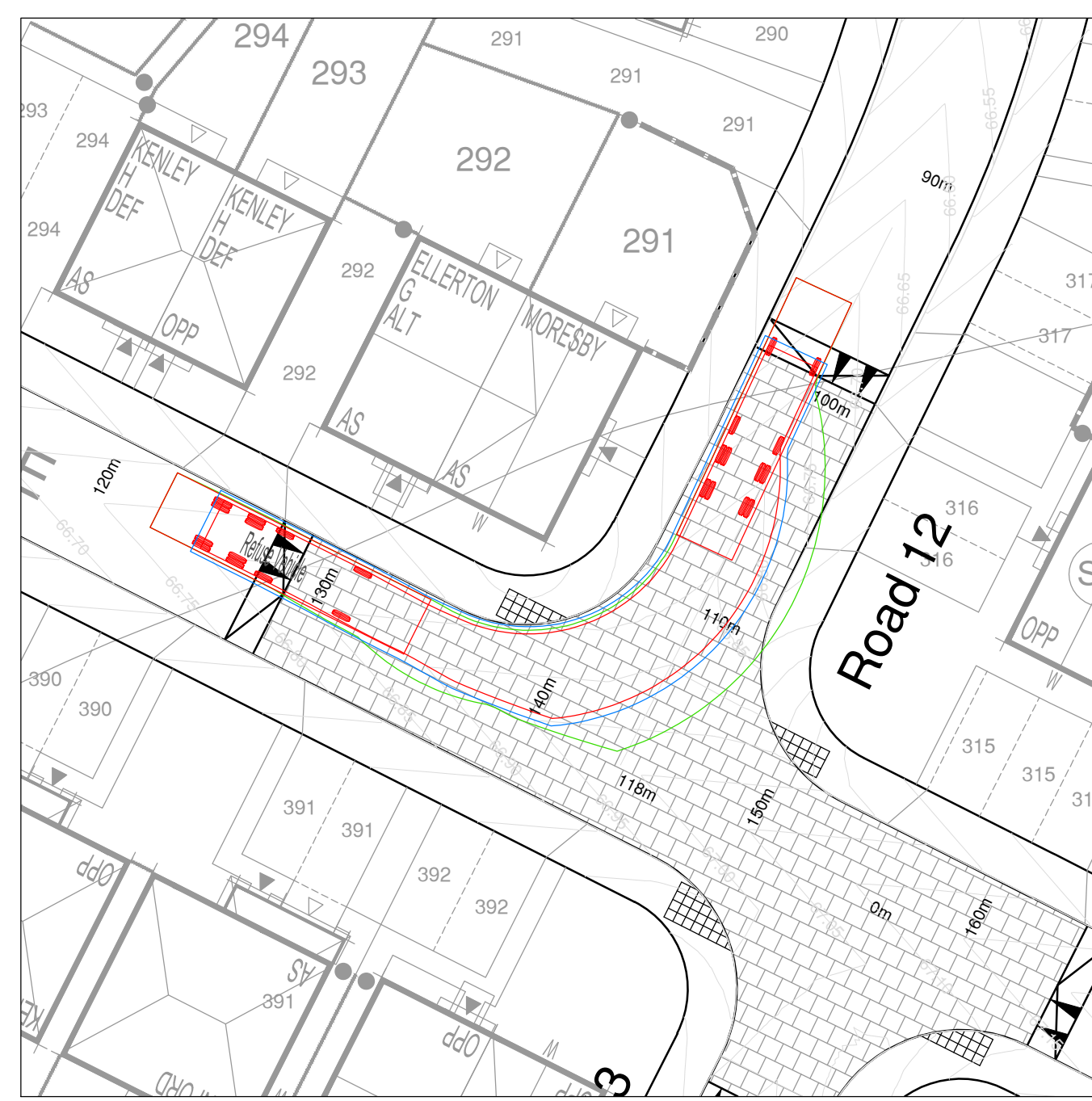

Left Turn - Road 10 to Road 12

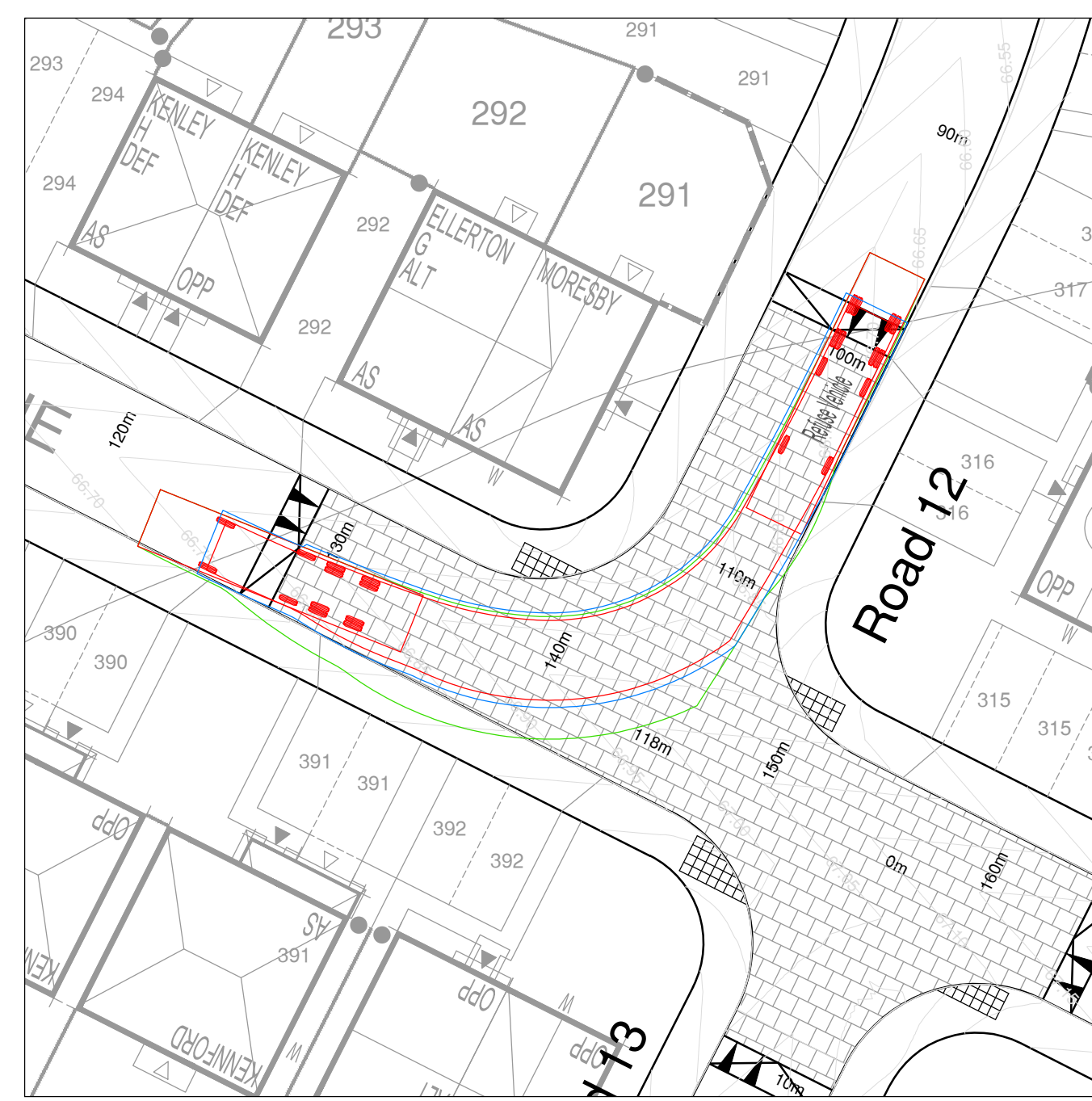

Right Turn - Road 12 to Road 10

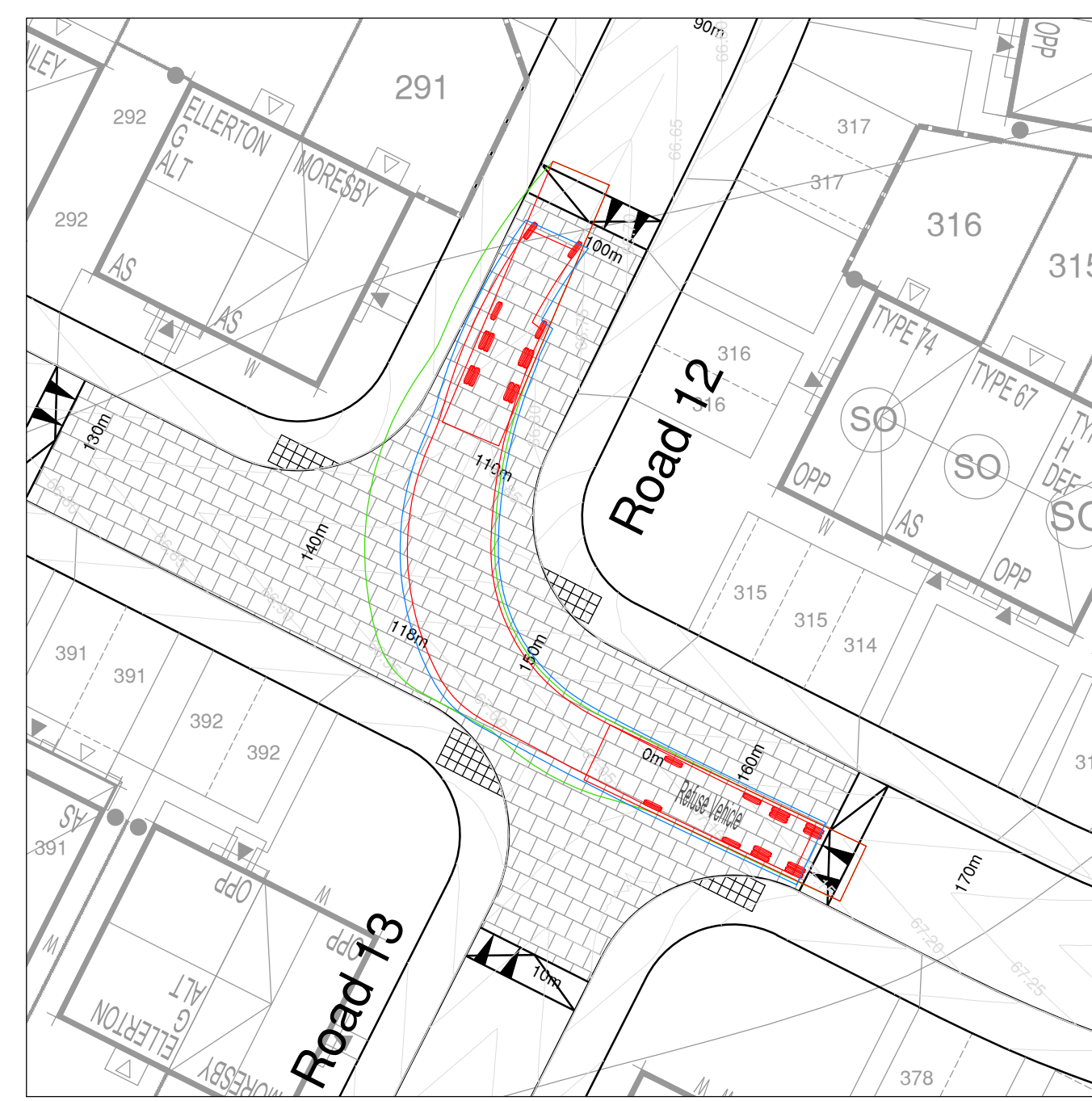

Right Turn - Road 10 to Road 12

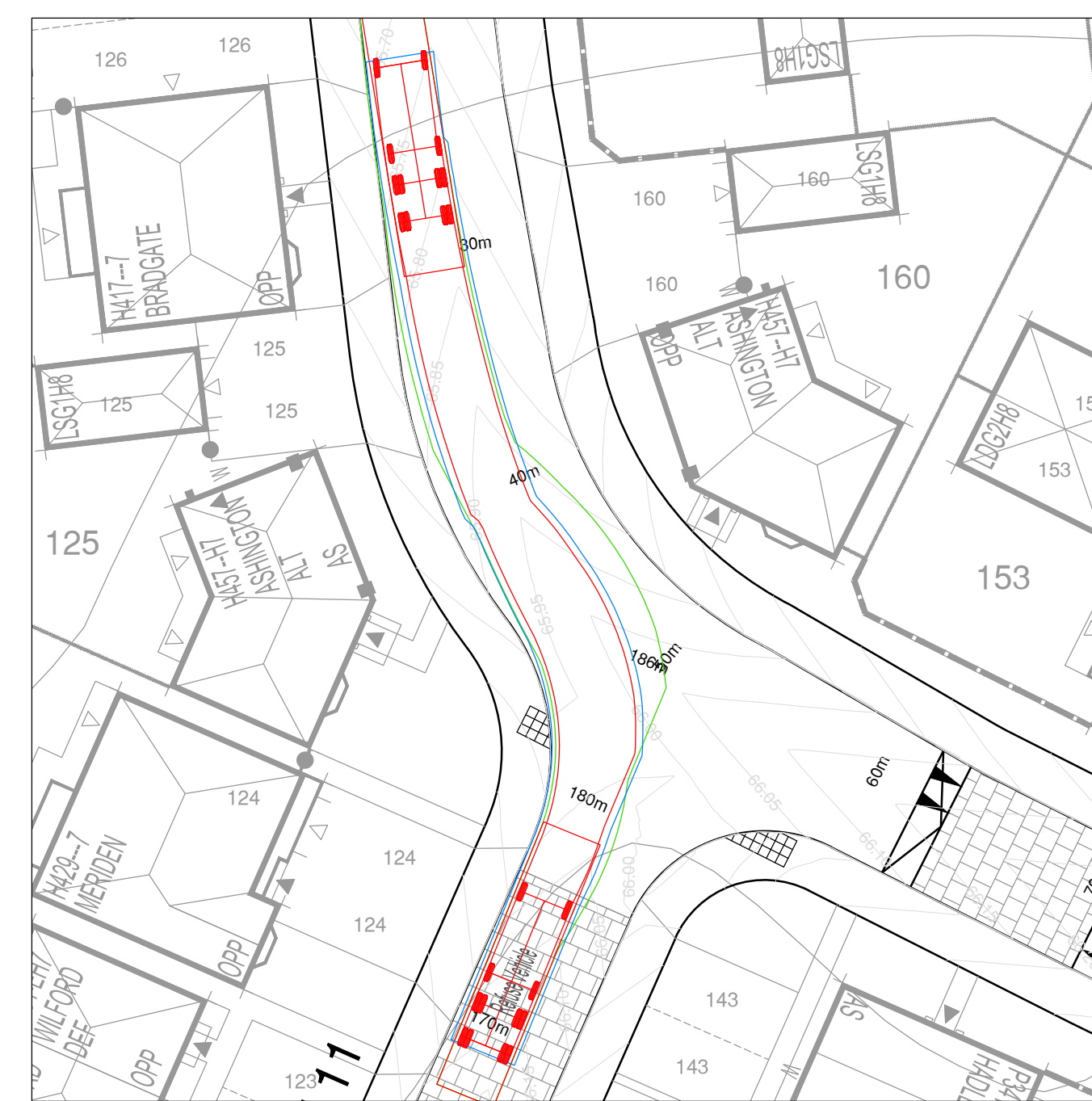

Right Turn - Road 11 to Road 10

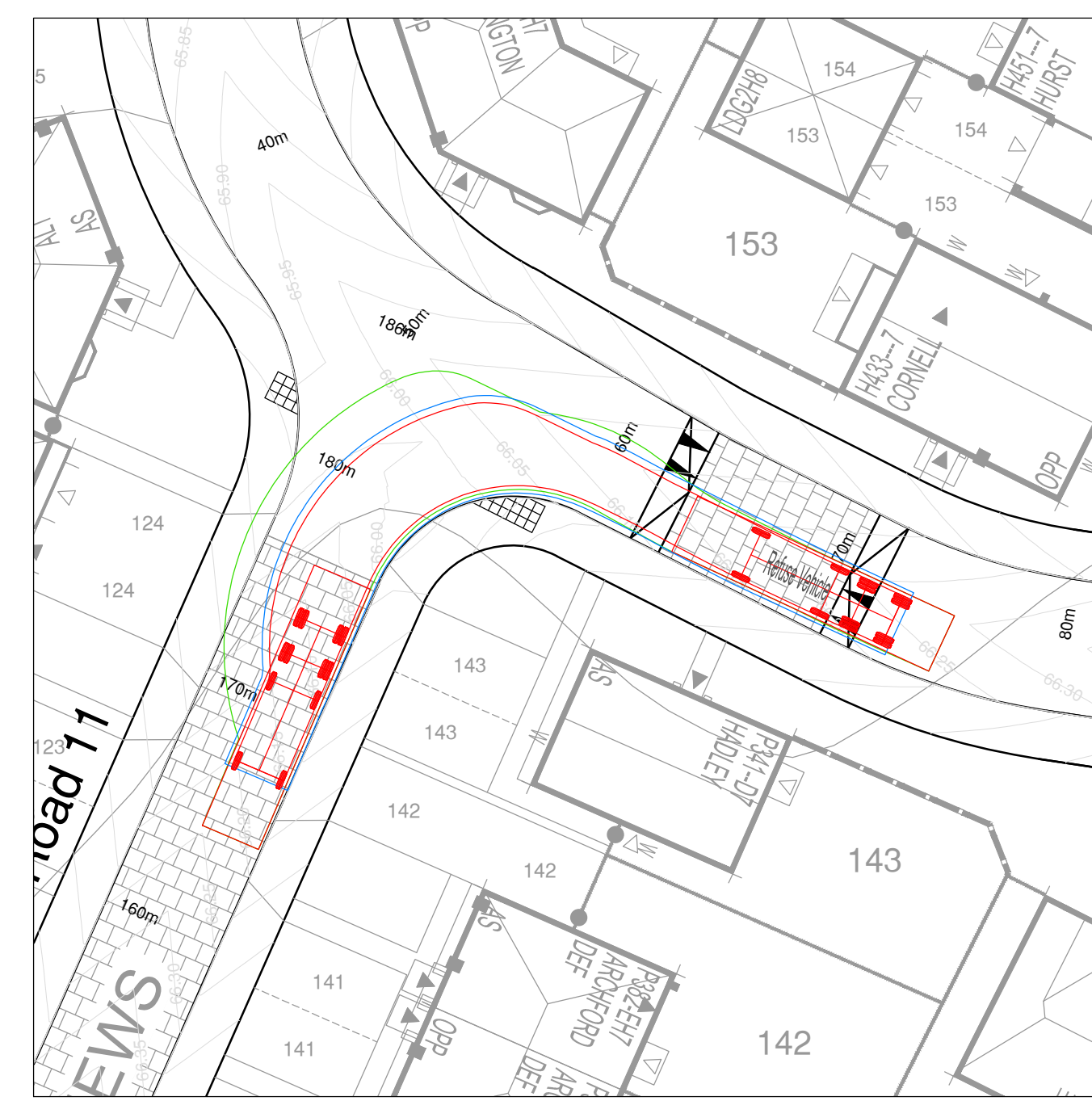

Left Turn - Road 10 to Road 11



Right Turn - Road 10 to Road 11

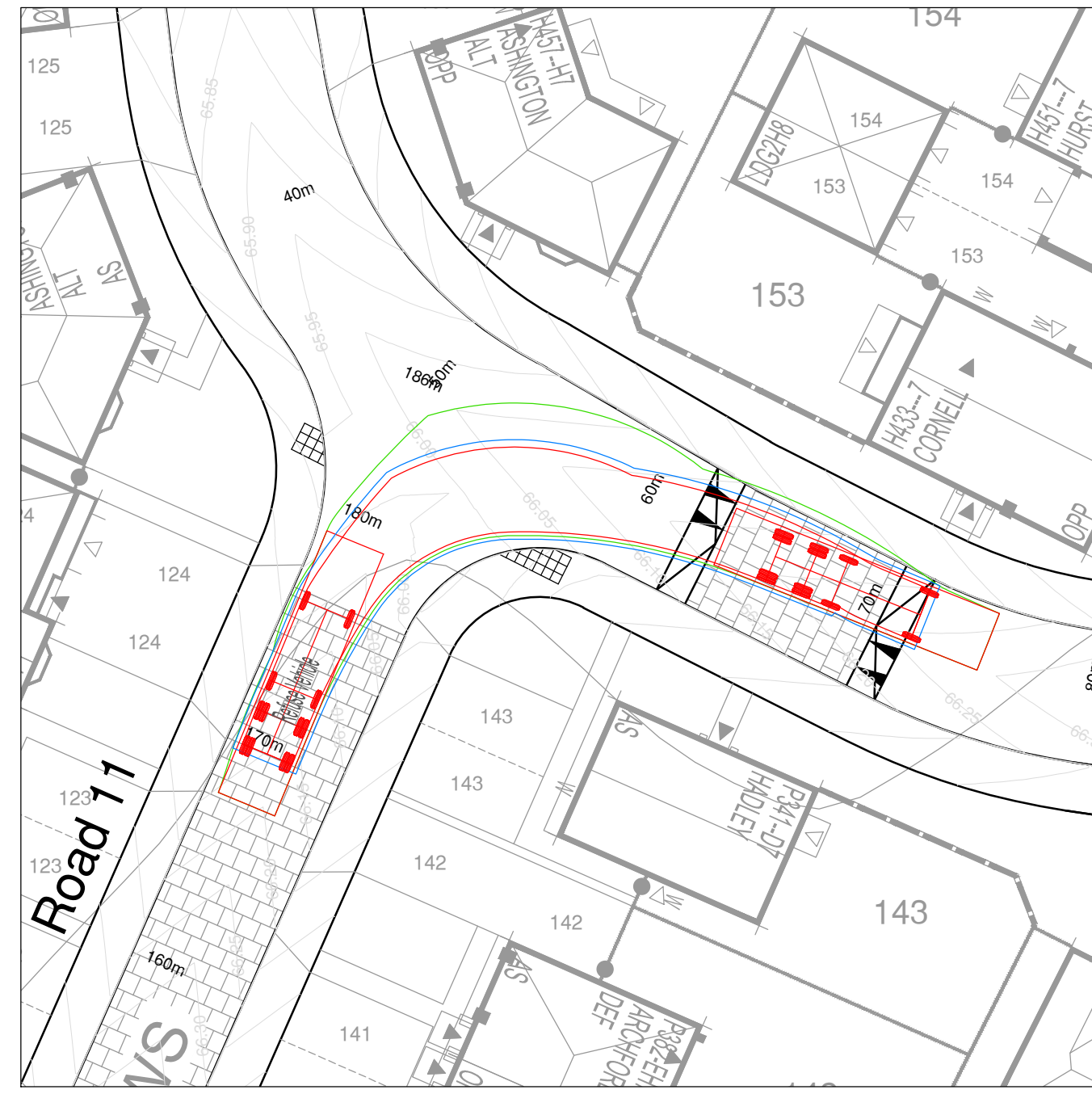

Right Turn - Road 11 to Road 10

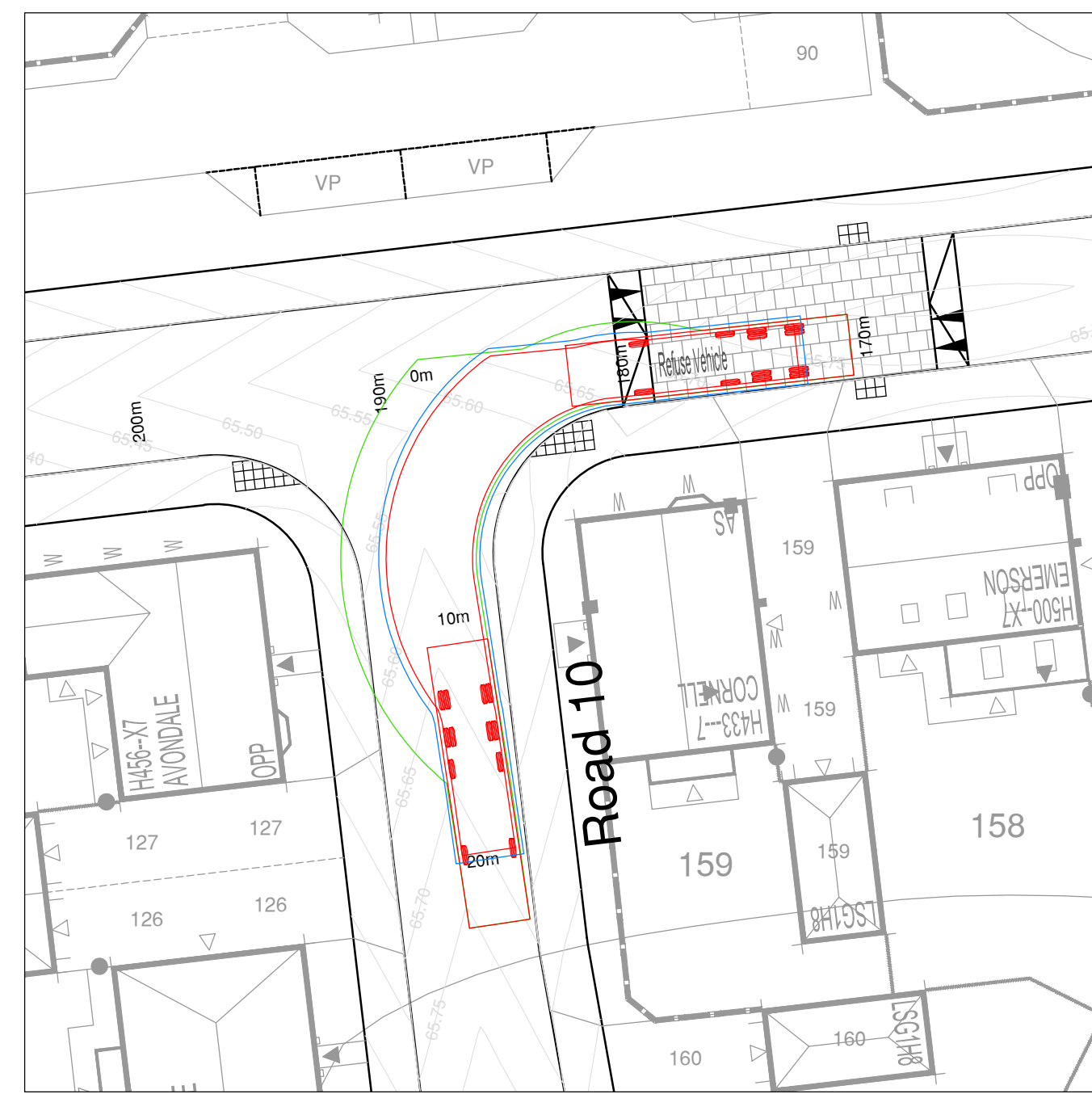

Left Turn - Road 8 to Road 10

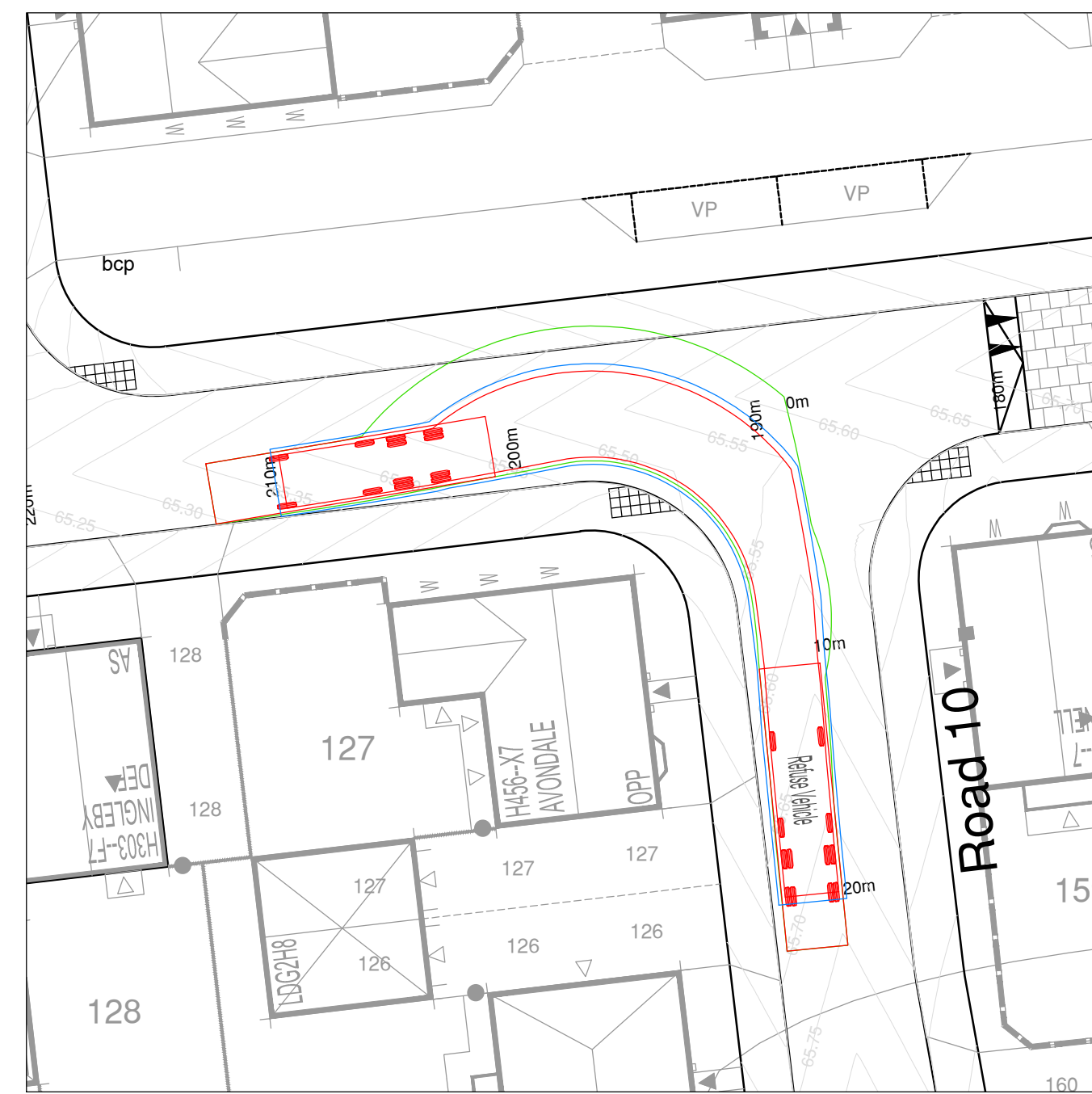

Left Turn - Road 10 to Road 8

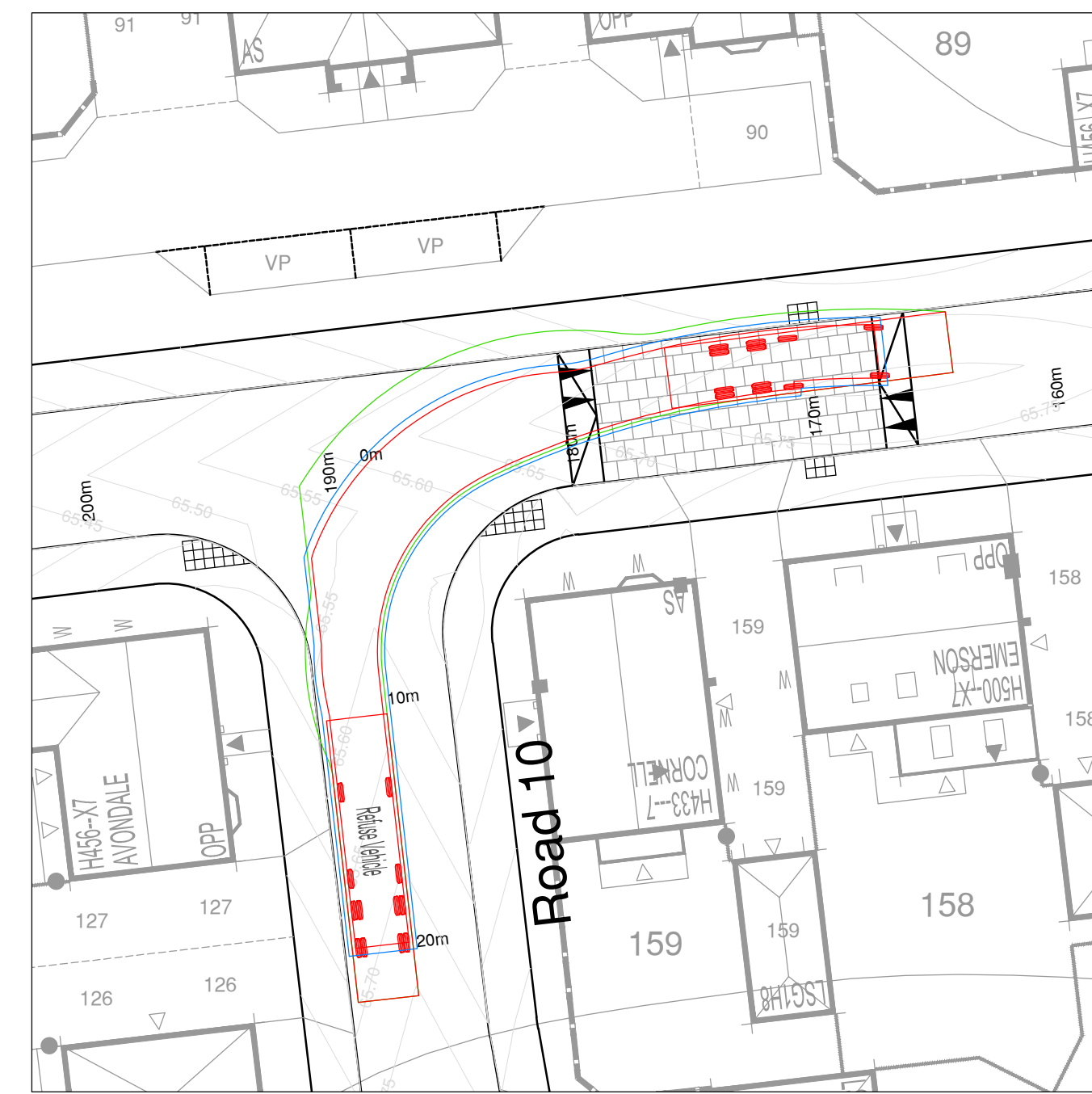

Right Turn - Road 10 to Road 8

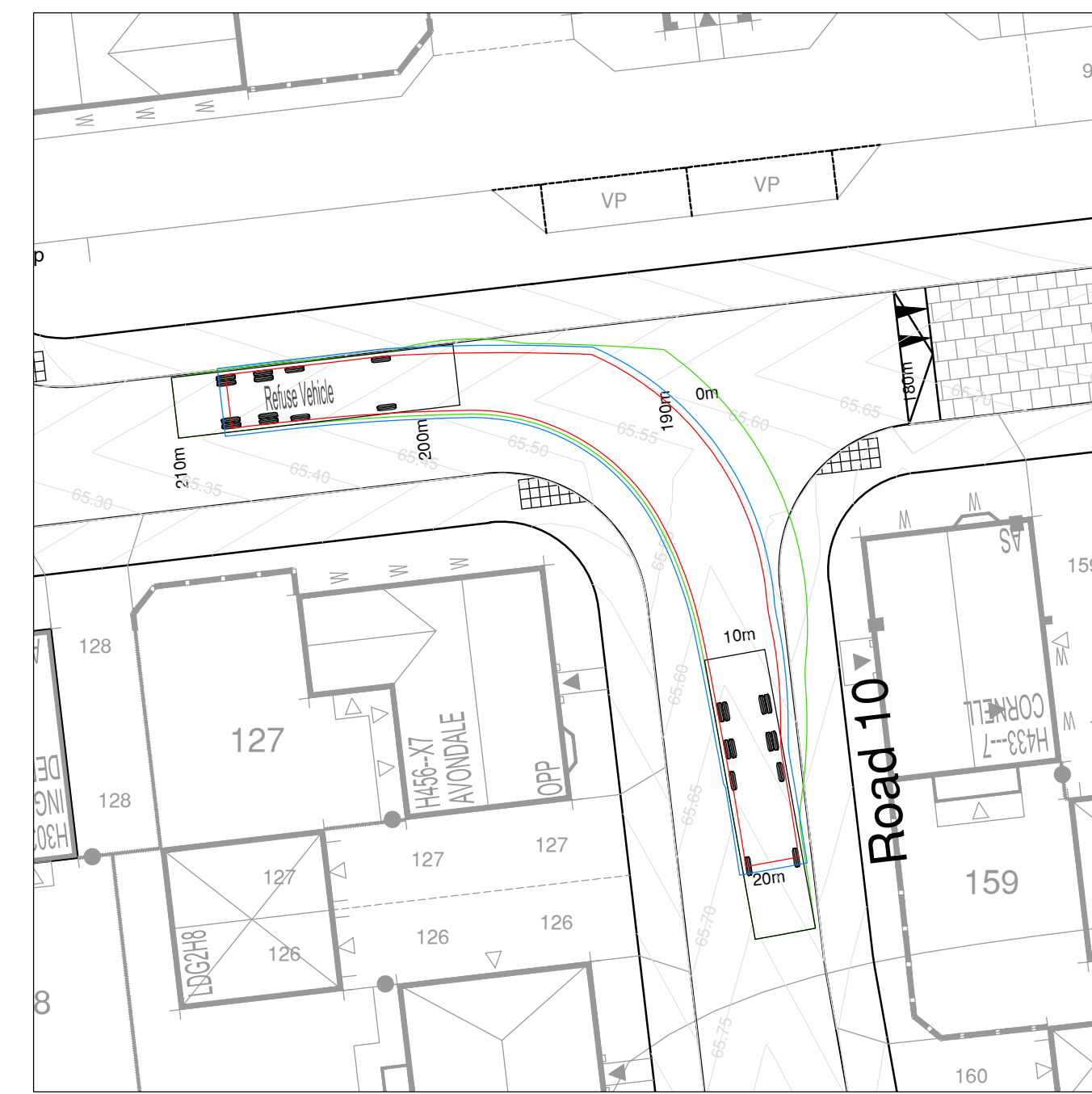

Right Turn - Road 8 to Road 10

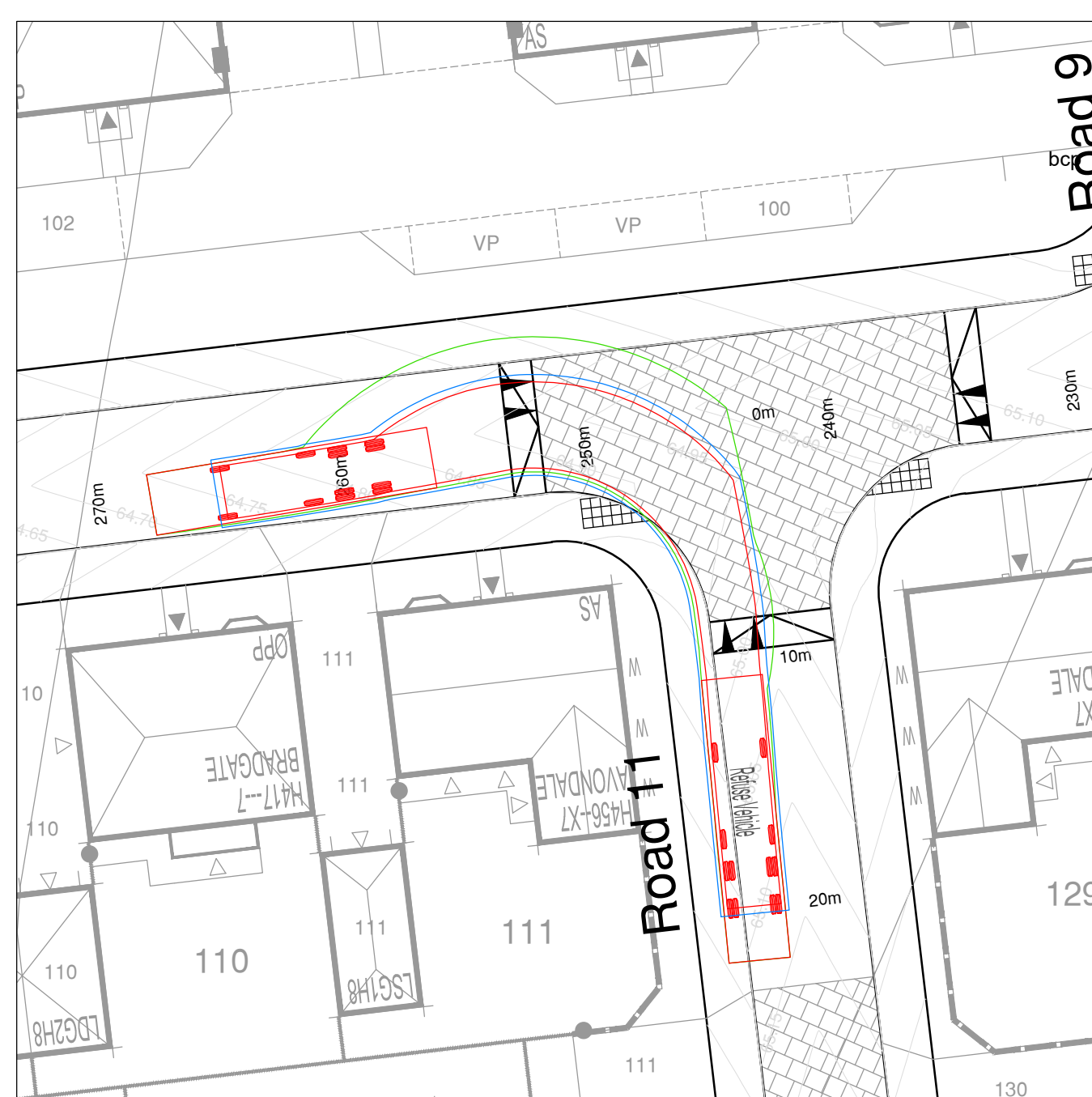

Left Turn - Road 11 to Road 8

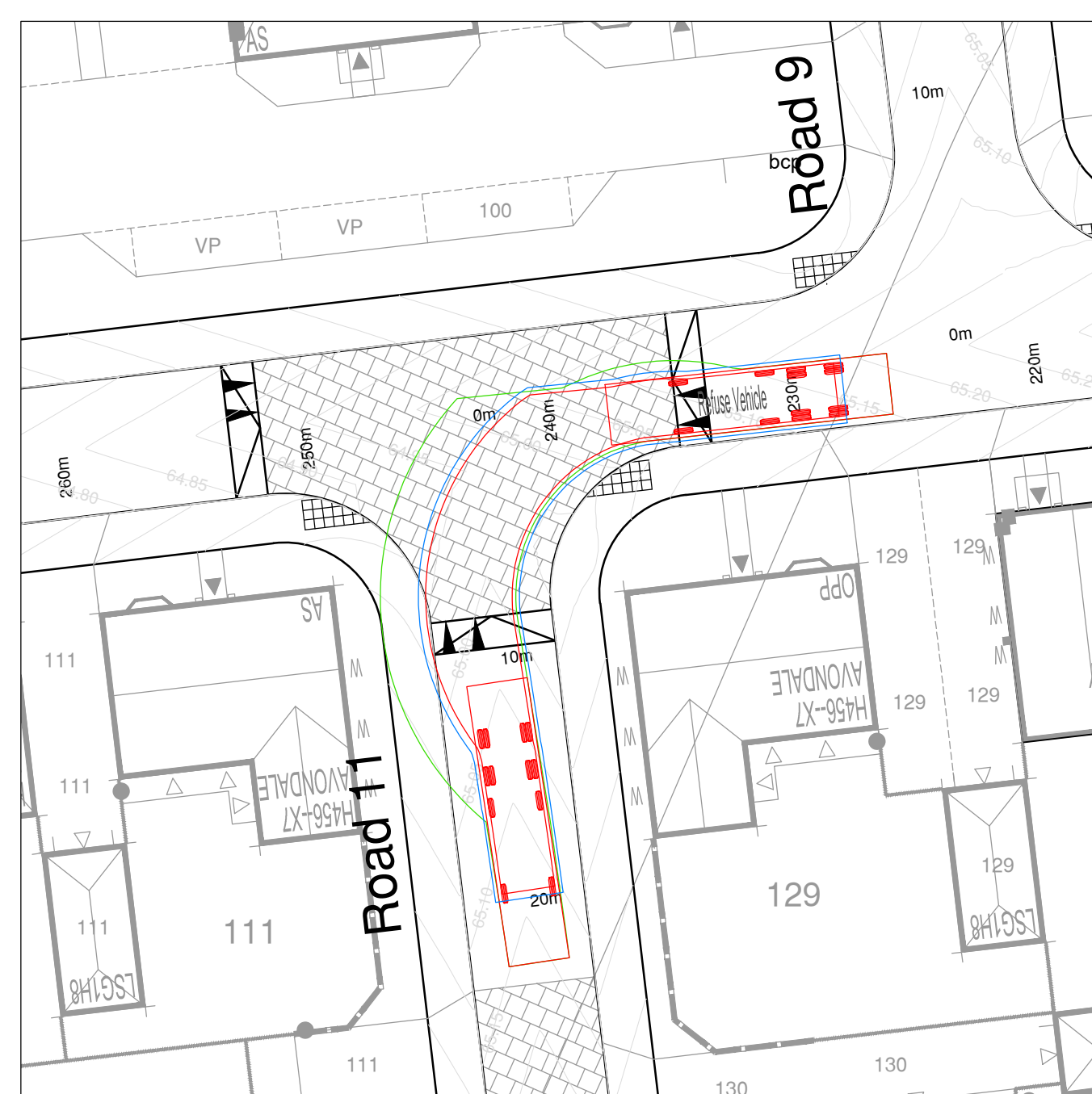

Left Turn - Road 8 to Road 11

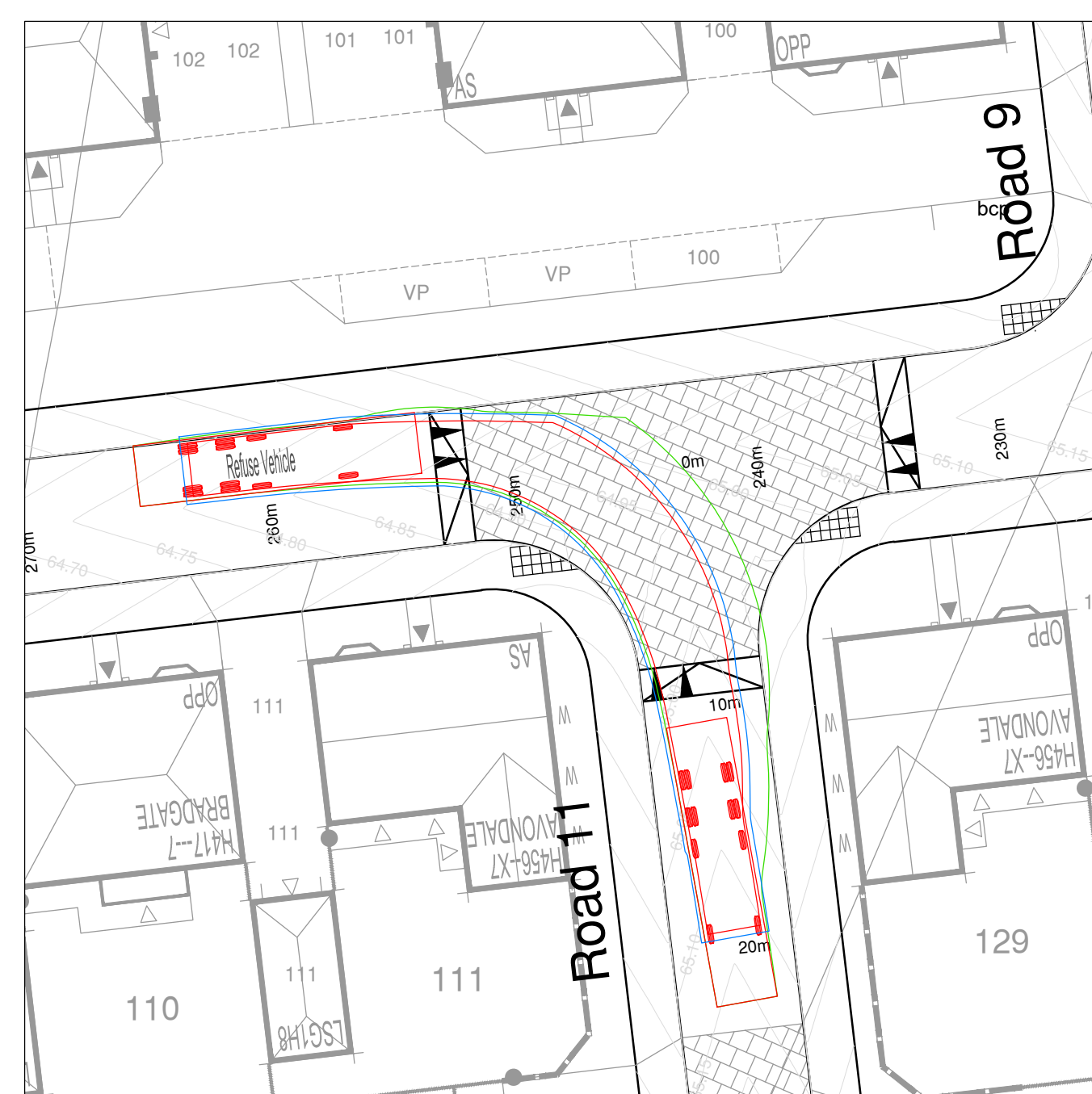

Right Turn - Road 8 to Road 11

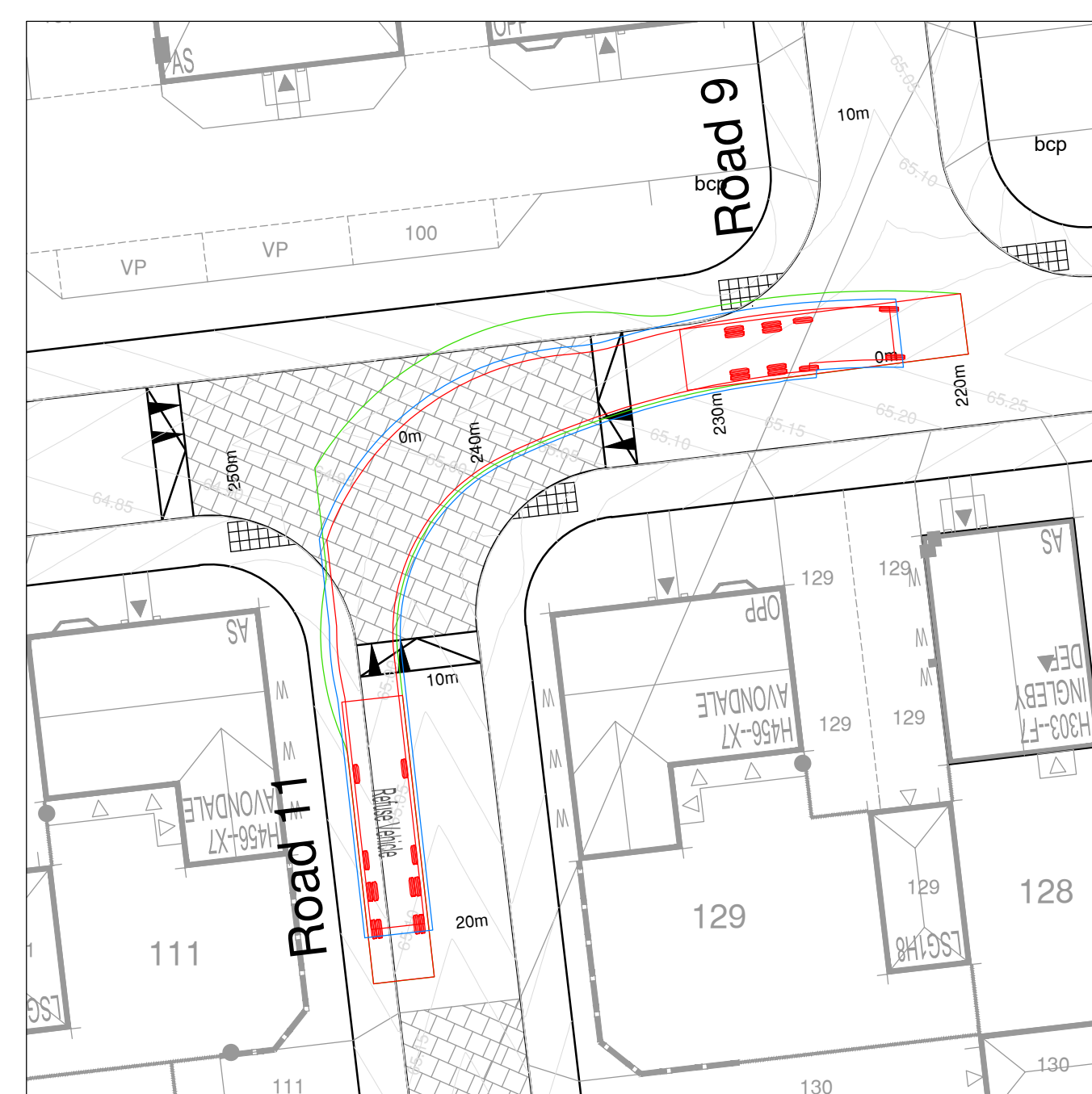

Right Turn - Road 11 to Road 8

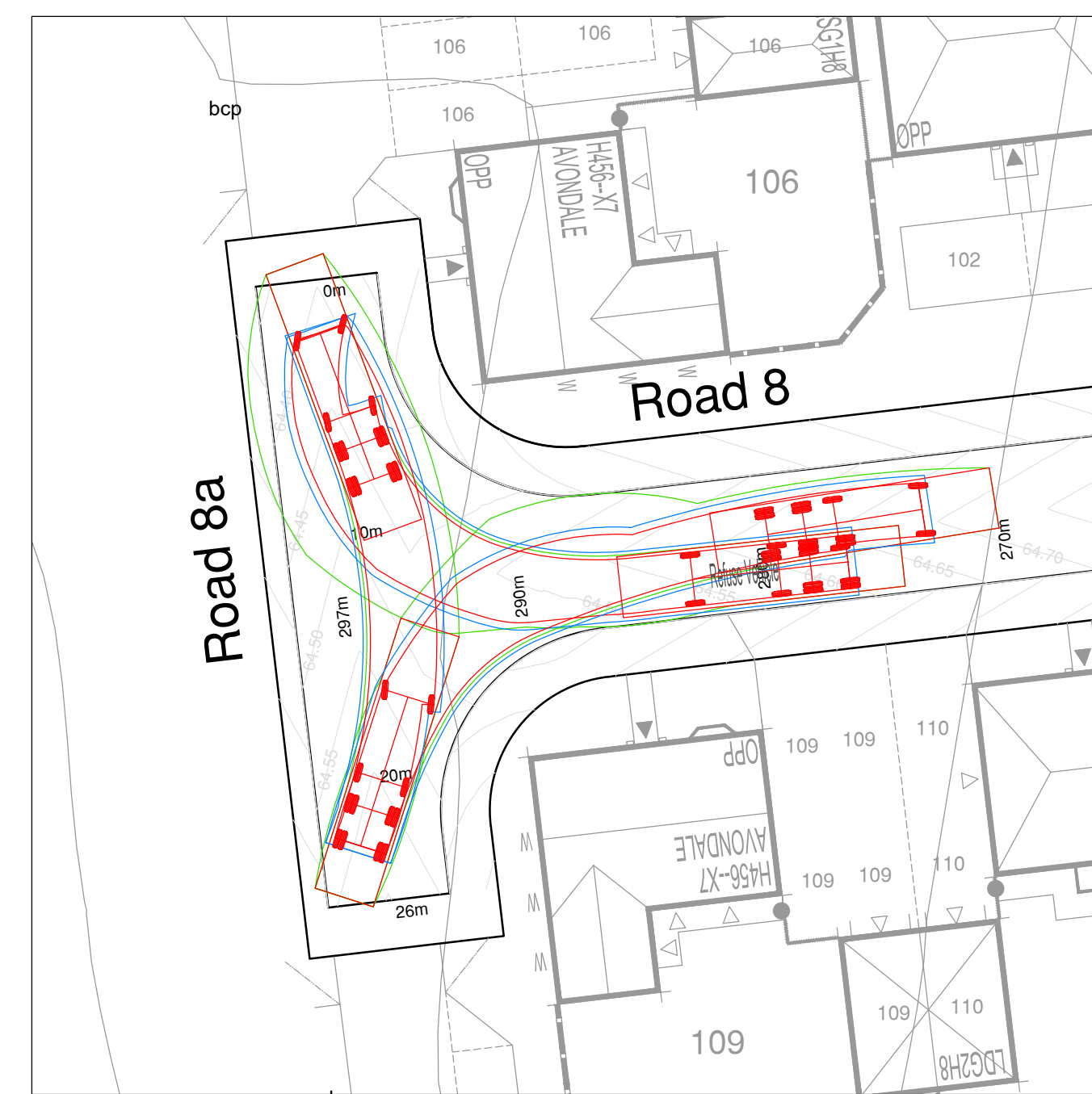

Turning Head - Road 8a

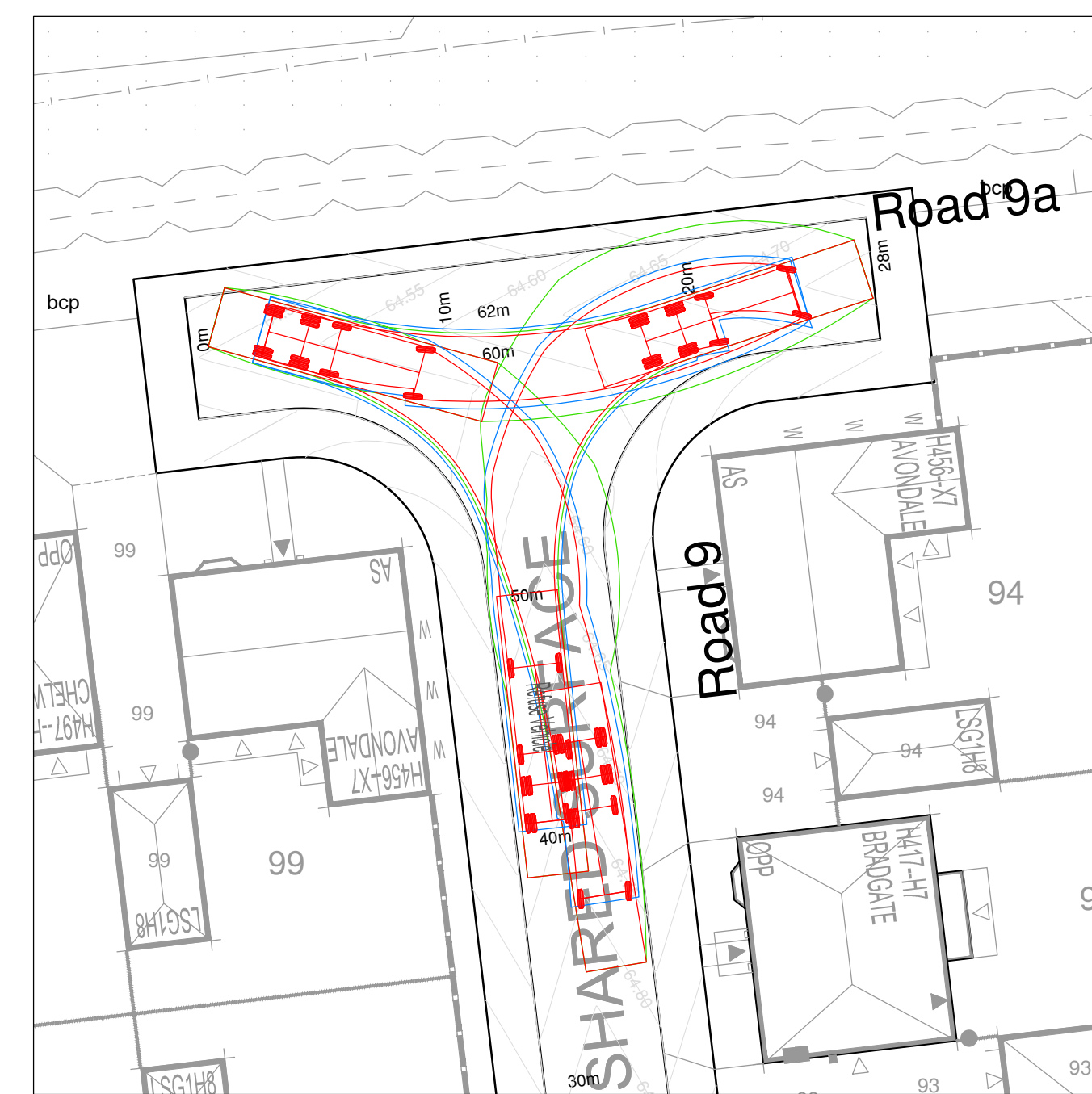

Turning Head - Road 9a

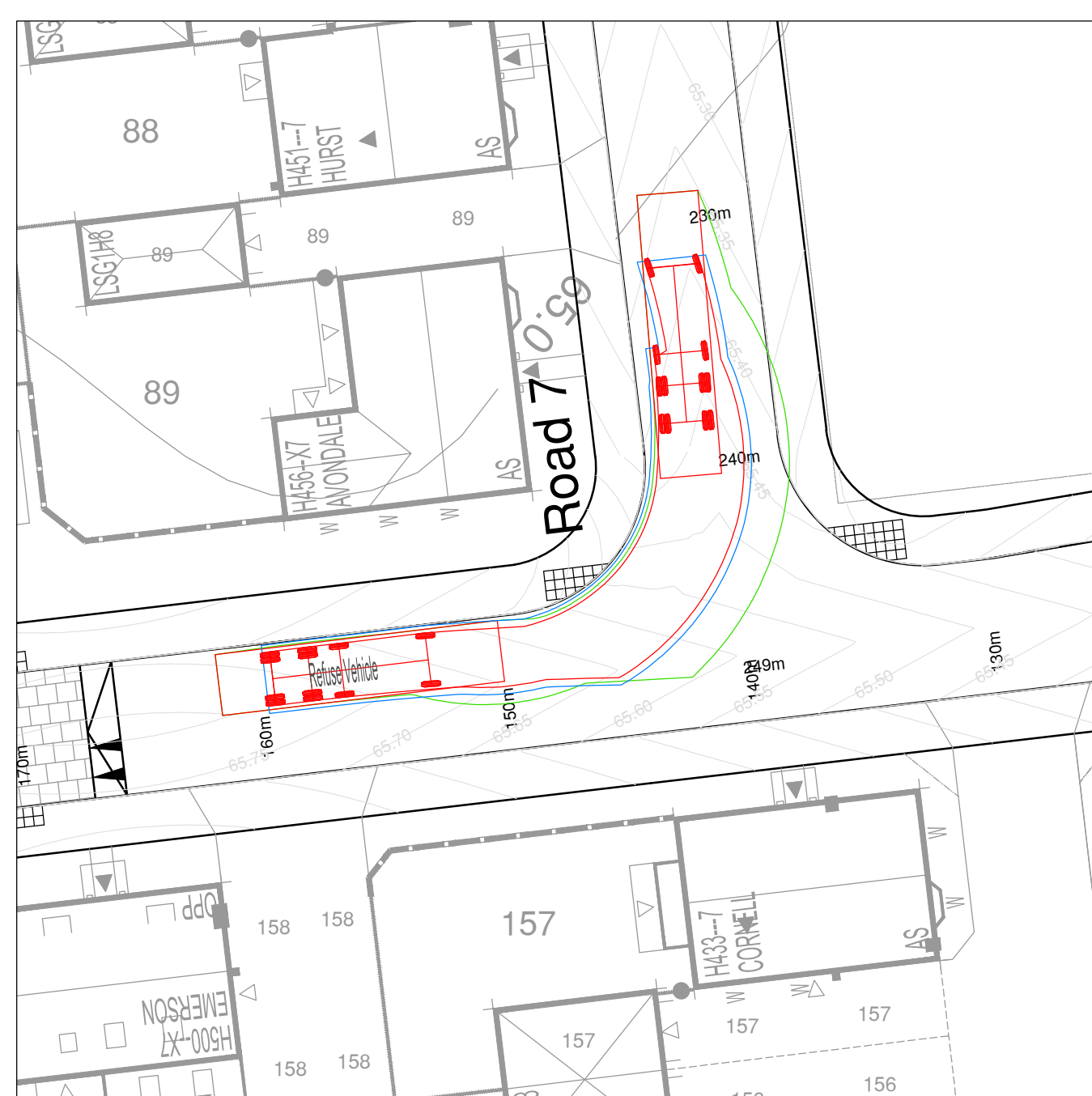

Left Turn - Road 8 to Road 7

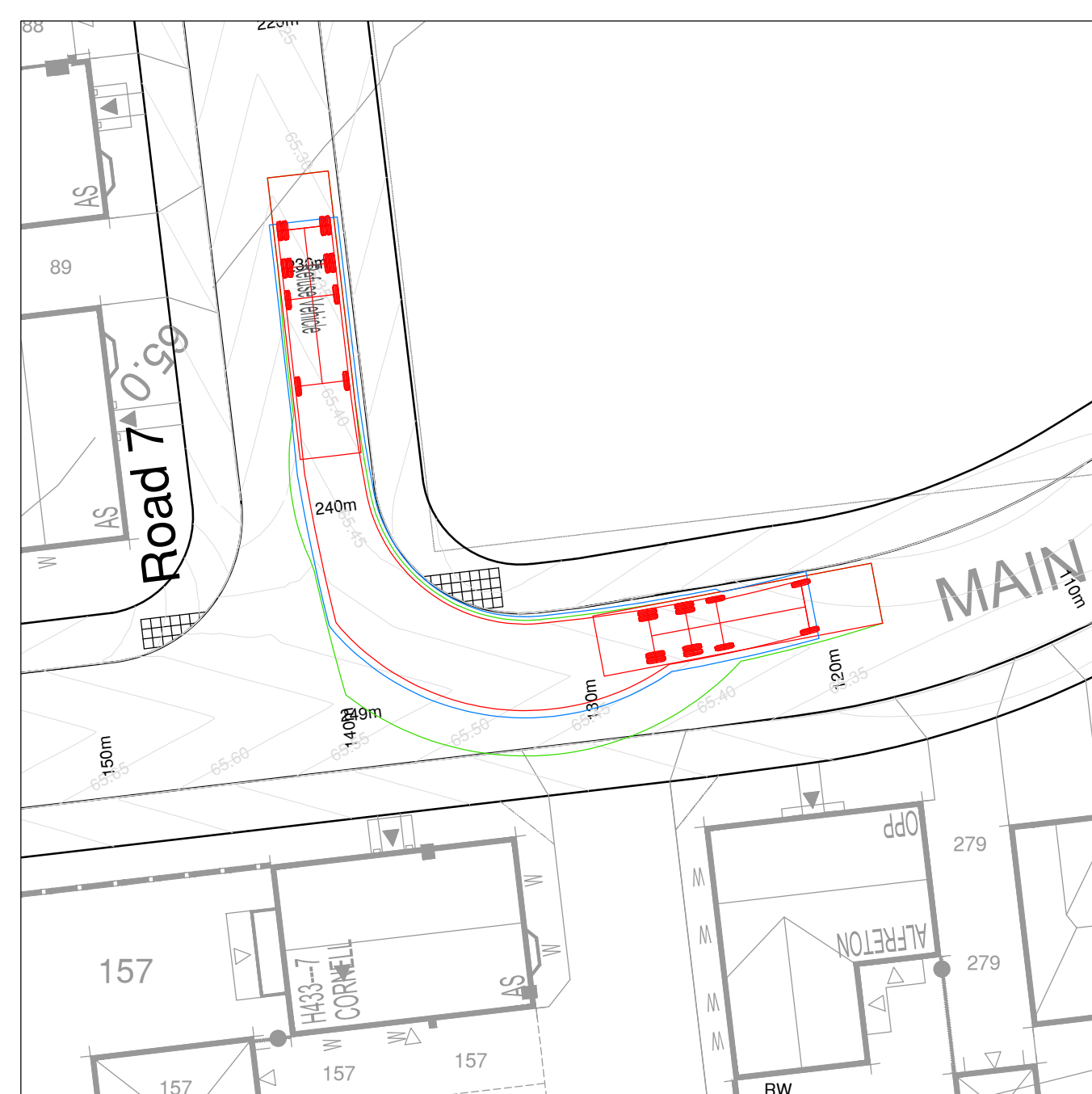

Left Turn - Road 7 to Road 8

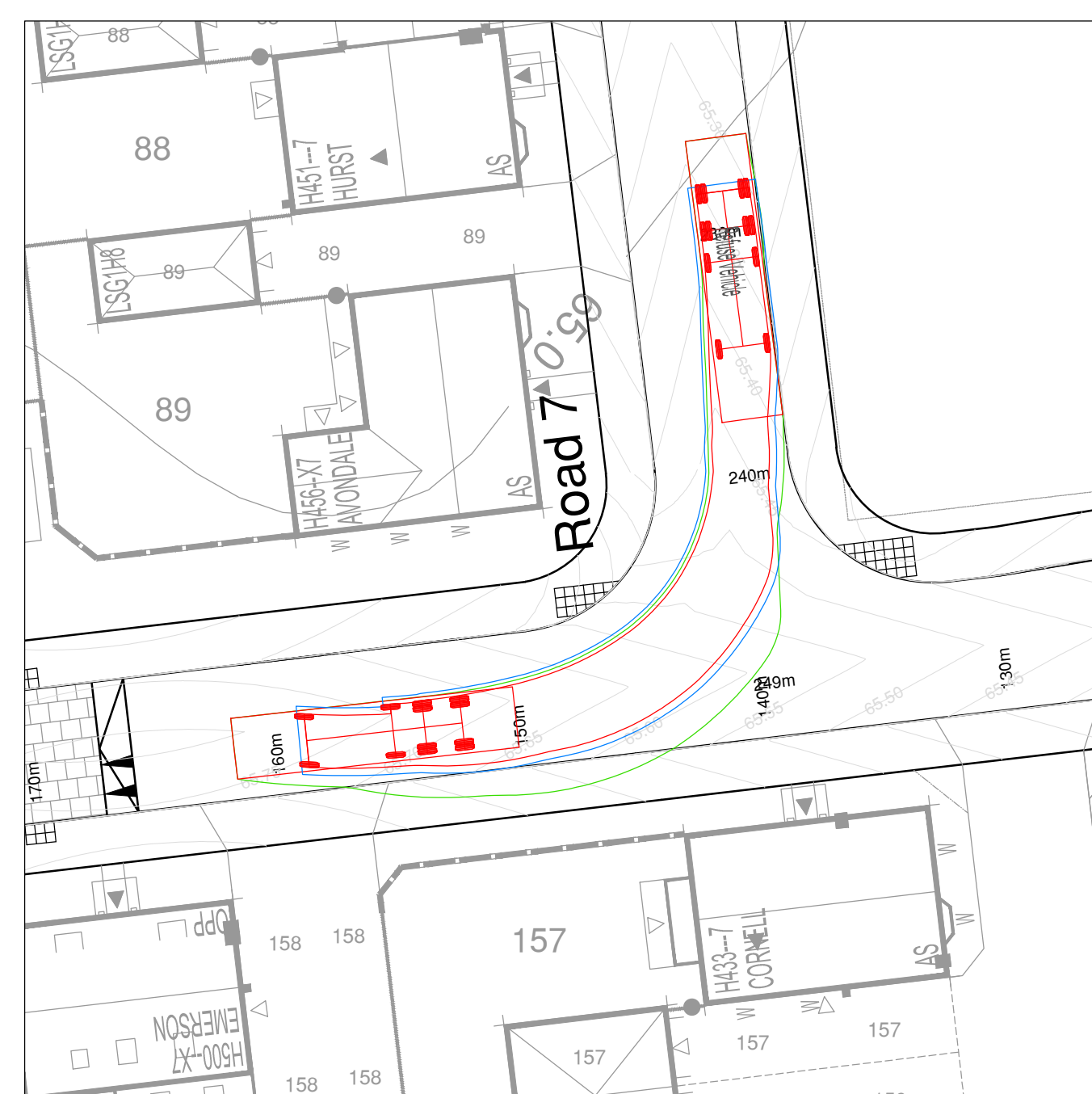

Right Turn - Road 7 to Road 8

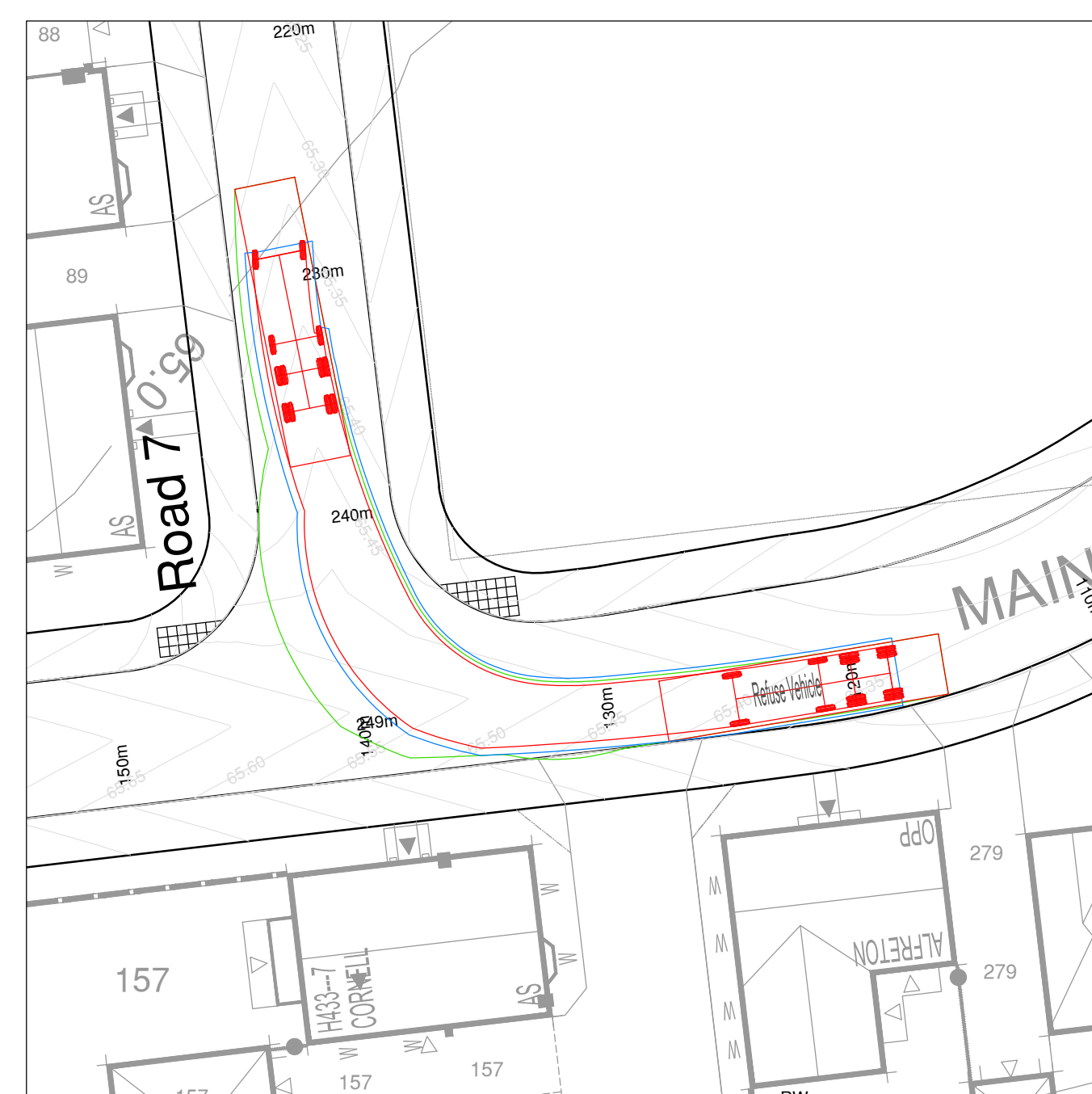

Right Turn - Road 8 to Road 7

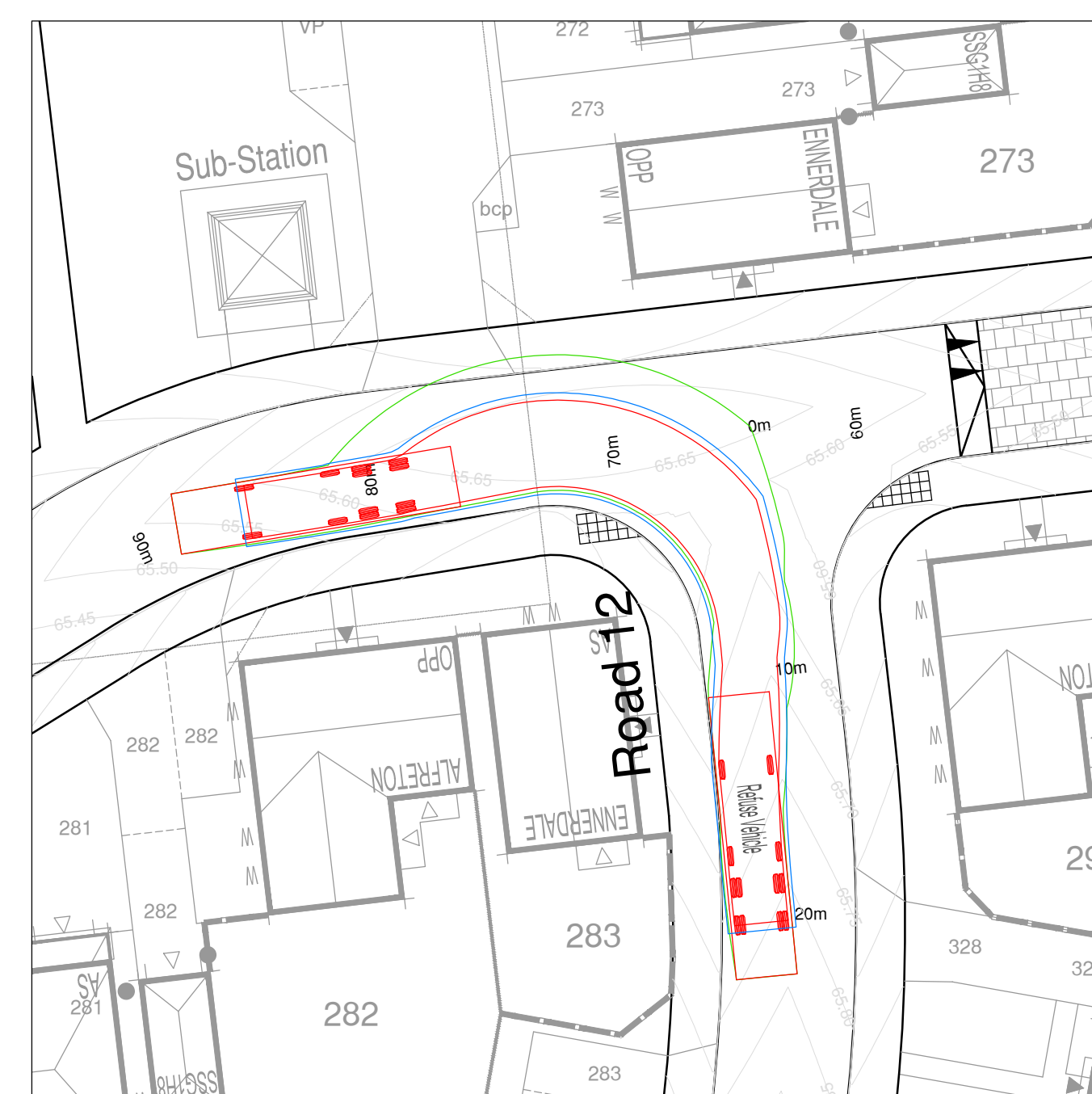

Left Turn - Road 12 to Road 7

GENERAL NOTES

- Do not scale this drawing. If in doubt, ask.
- This drawing is to be read in conjunction with all other relevant Engineers, Architects and specialist design drawings and details.
- All dimensions are in metres unless noted otherwise. All levels are in metres unless noted otherwise.
- Any discrepancies noted on site are to be reported to the Engineer immediately.
- All levels are subject to detailed design and may vary +/-500mm.
- T1 to T3 taken at typical straight approach T-Junctions, location and orientation will vary, refer to locating plan.

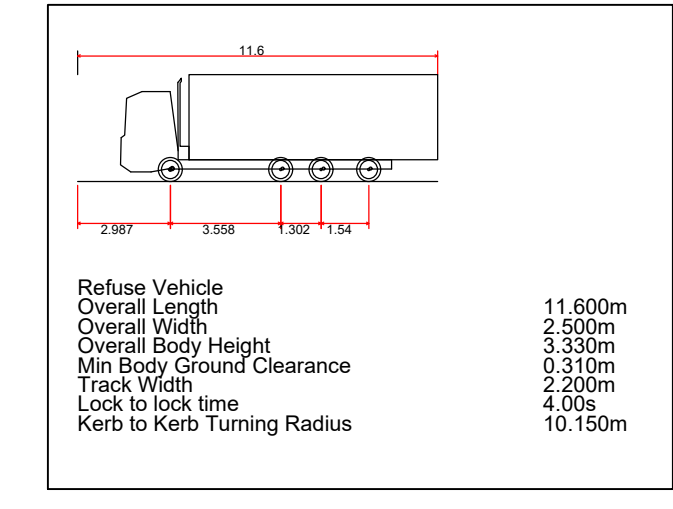

Rev	Description	Initial	Date
A	Adaptor to turning head details	MJA	26.02.21
B	Additional tracking added	BL	02.09.21
C	Updated to status approved for use AFU	JZ	07.01.22

WARNING TO PURCHASERS, Property Misdescriptions Act 1991
 The purchaser should be advised that this drawing is for information only and should be treated as general guidance.
 It is the purchaser's responsibility to ensure that the drawing is read in conjunction with all other relevant drawings and details.
 The purchaser should be advised that this drawing is for information only and should be treated as general guidance.
 It is the purchaser's responsibility to ensure that the drawing is read in conjunction with all other relevant drawings and details.