

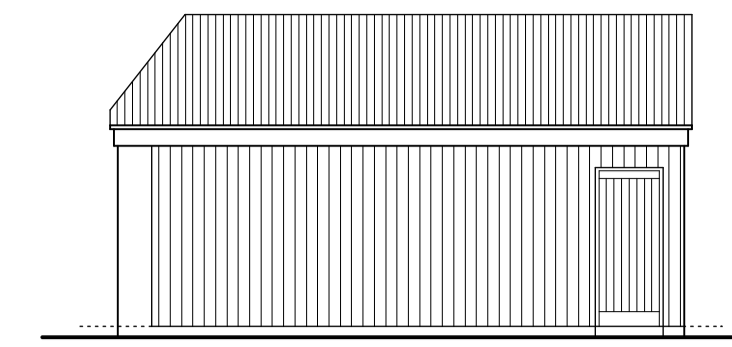

Site Layout Plan. 1:250

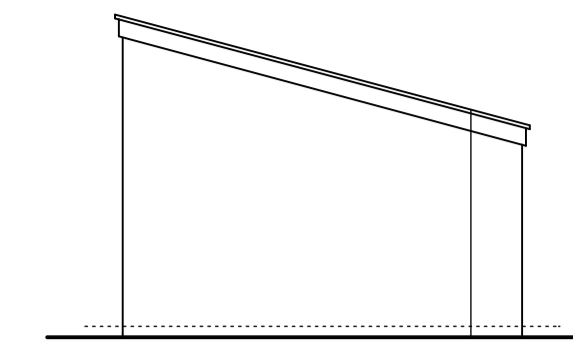

North Elevation. 1:100



East Elevation. 1:100

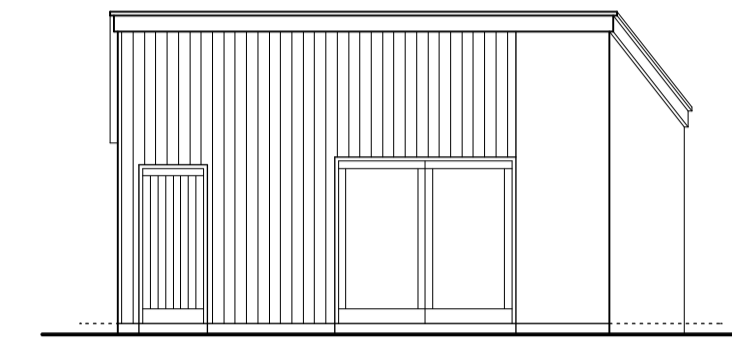

South Elevation. 1:100

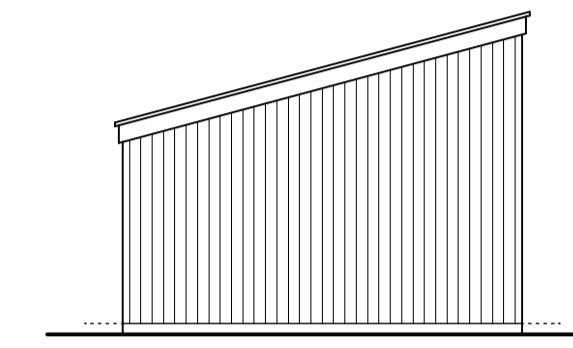

West Elevation. 1:100

Garage Elevations

Proposed Finishes

- House**
- Walls Wet Dash Harl
Vertical Timber Linings
 - Roof Slates
 - Windows Timber - Painted White
 - External Doors Timber - Painted White
- Garage**
- Walls Wet Dash Harl
Vertical Timber Linings
 - Roof Profiled Metal Sheeting
 - External Doors Timber - Painted White

No	Revisions	Date	Initials
A	Drainage on Site Layout Plan	09.05.22	MR

**MANTELL
RITCHIE**

Chartered Architects

27A High Street, BANFF,
AB45 1AN
Tel: 01261 812267
Email: admin@mantellritchie.co.uk
www.mantellritchie.com



Copyright of Mantell Ritchie, Chartered Architect.

project
**188 Seatown,
CULLEN.**
Proposed Alterations
for
Mr + Mrs D Pritchard

content
Site Layout Plan and Garage Elevations

scales	drawn by	size	date
1:100, 1:250	MR	A1	26.04.22

ref **21170** **02A**