

**LEGEND**

SELF SERVICE MACHINE/  
EQUIPMENT/FURNITURE  
BEING INSTALLED

AREA OF REQUIRED ADJUSTMENT  
(EXISTING / PROPOSED)

REFER TO PR01-PL1  
FOR SCOPE OF WORKS.



Scale - meters

**CCTV CAMERA SPECIFICATION (NTS)**

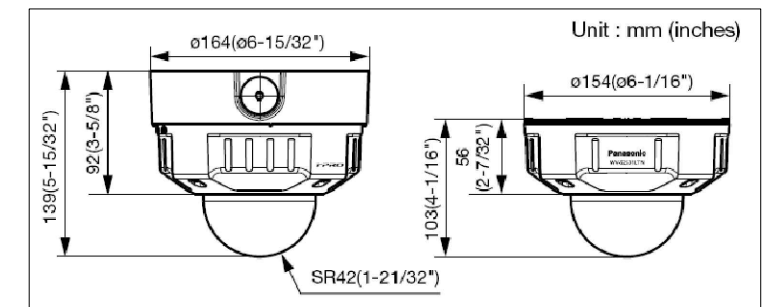

**CCTV CAMERA BRACKET SPECIFICATION (NTS)**



Notes:	Rev	Date	Notes	Rev	Date	Notes
<p>Copyright of this drawing is reserved by AXIS Architecture and issued on the condition that it is not copied, reproduced or disclosed to any third party either wholly or in part without the consent in writing of AXIS Architecture.</p> <p>The contractor must verify all dimensions on site before making shop drawings or commencing work of any kind.</p>			<p><b>RESIDUAL RISK</b></p> <p>Wherever possible unnecessary risk is designed out of these proposals. Where residual risk remains this is assessed and identified on the relevant drawings with this symbol. Refer to the note and the relevant measures in the Health + Safety documentation</p>			

Client Corporate Real Estate	Project Blackpool Oxford Square	Title Proposed Elevations Front Overall
Status <b>PLANNING DRAWING</b>	Scale A1 1:50 A3 1:100	Date 18.05.22
AXIS Architecture and Design Ltd, Talbot Chambers, 2-6 North Church Street, Sheffield, S1 2DH.	Drawn LDD	Checked RAS
Job No. 27637-013-PR03-PL1	Revision -	<p>tel: +44(0)114 2490944 fax: +44(0)114 2490966 www.axis-architecture.com designed@axis-architecture.com</p>