

DRAWING NOTES

COPYRIGHT ©
This drawing and the details herein are the copyright of MBH Design Studio Ltd. and must not be reproduced, altered or passed to any third party without prior written consent.
This drawing has been produced for the project listed below, is submitted in support of this application to the Local Planning Authority and is not intended for use by any other person or for any other purpose.
Every effort has been made to ensure the accuracy of these drawings, however MBH Design Studio Ltd. accept no responsibility for any discrepancies arising from the reuse of survey information and preliminary drawings commissioned by the Applicant from others.

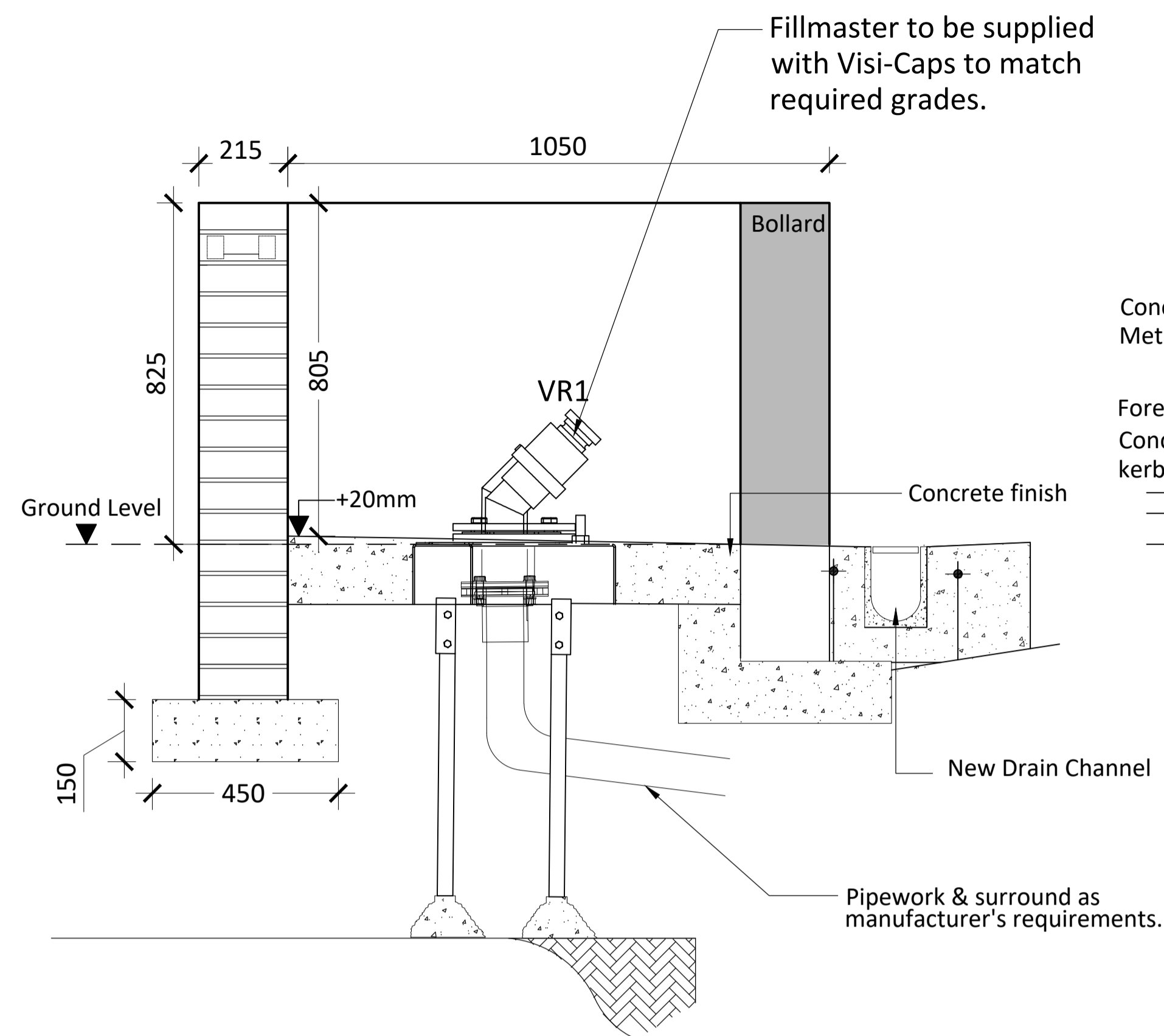

SIDE ELEVATION

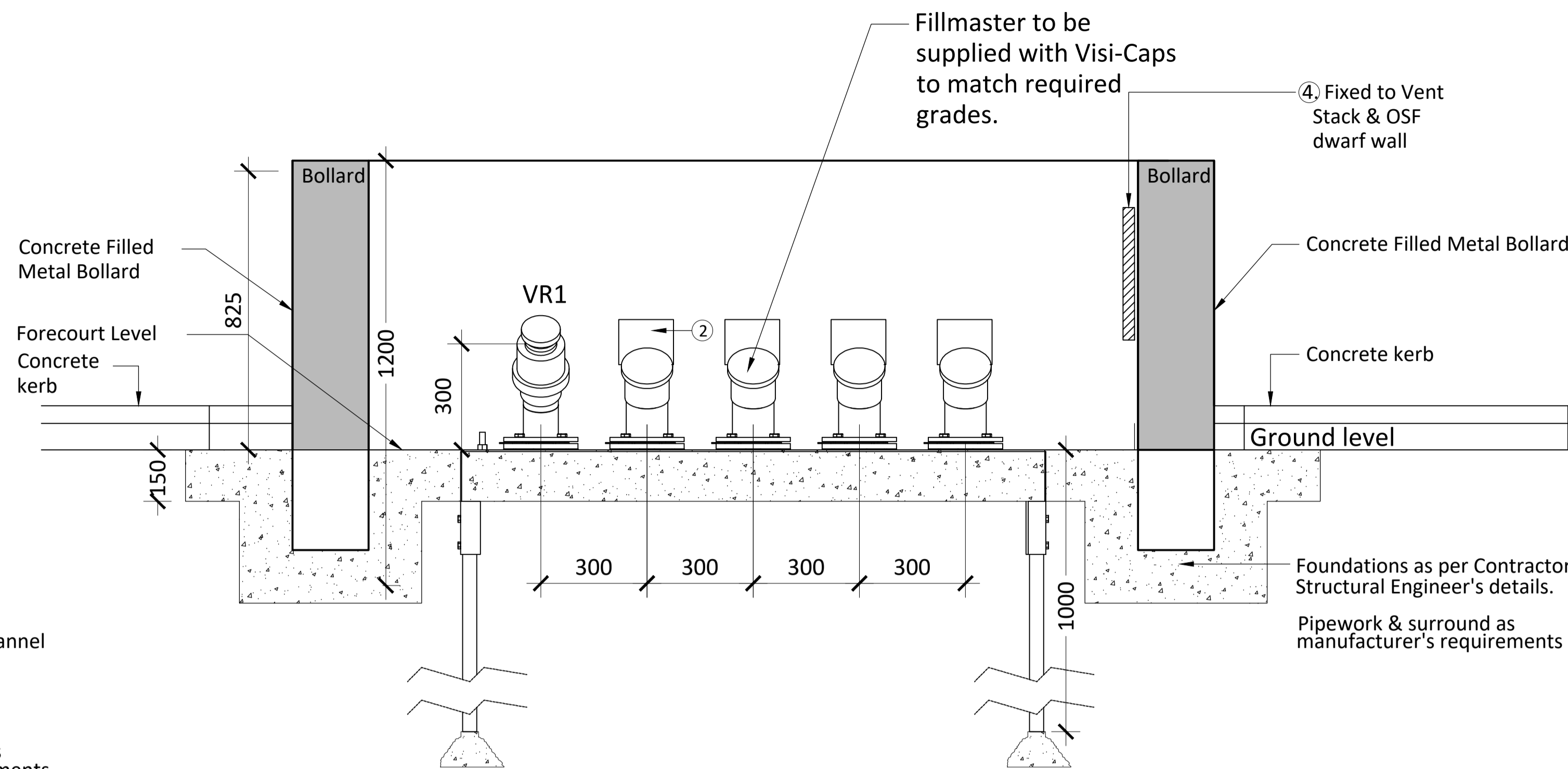

FRONT ELEVATION

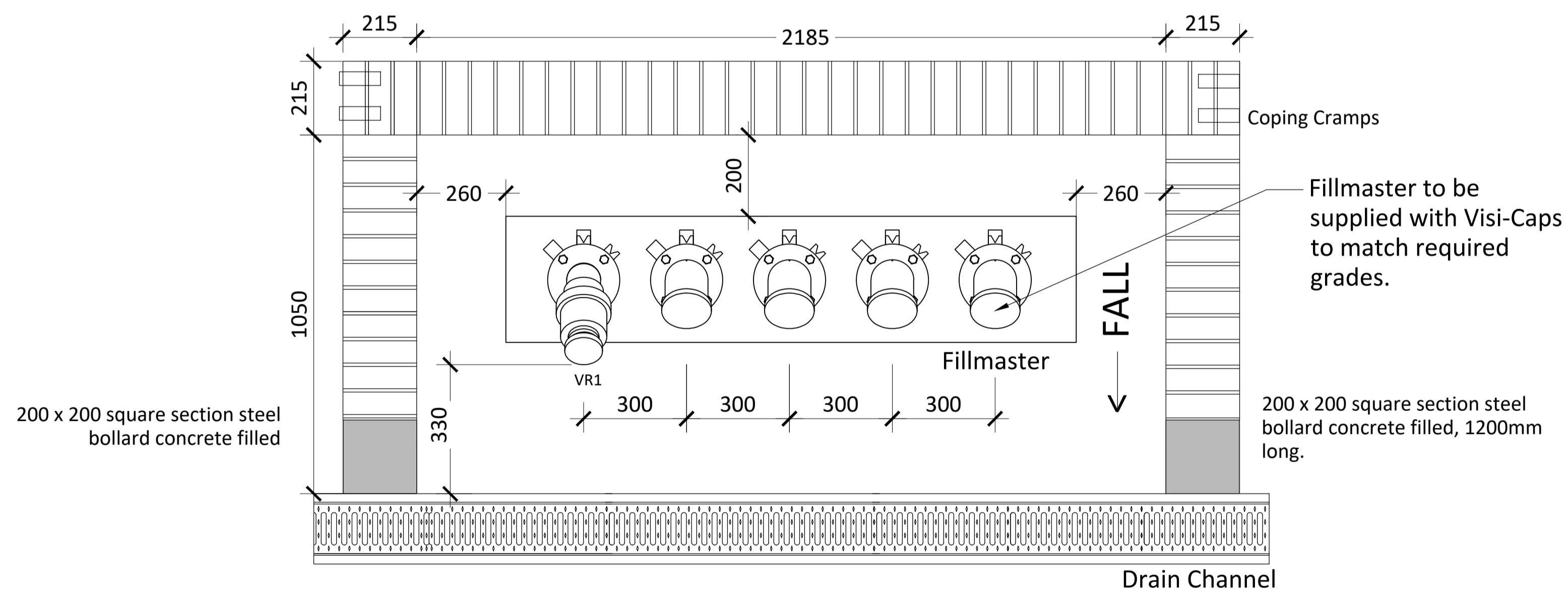

PLAN

Notes

Signage:-

1. Vapour Recovery - Warning Sign/Connect connect VR hose etc.
2. Offset Fills - OSF tank number, grade, safe working capacity and warning sign, overfill prevention device fitted.
3. No Smoking - Standard No Smoking Sign.

Grounding:

4. Grounding of all conductive components within hazardous zone is elementary safety measure as it ensures equalizing of electrical potential of different parts in environment and hence avoids possible static electricity discharges including sparks which may ignite the explosive atmosphere.
5. Provide robust quality check of grounding including site inspection & certification by authorized body (Check grounding completeness also during site handover process.).
6. Welding pins of fusion fittings (UPP) to be protected with plastic cap as they can be hardly grounded.

REV	DATE	DESCRIPTION	DRAWN/CHECKED
REVISION NOTES			
PLANNING			
 <small>MBH Design Studio Ltd. Rosemount House, Rosemount Avenue, West Byfleet, Surrey, KT14 6LB www.mbhstd.com t: 01932 352 727 f: 01932 351 545</small>			
			
CLIENT			
PROJECT			
FS931 OAKLANDS SIDMOUTH SIDMOUTH ROAD, ALYESBEARE, EXETER, DEVON EX5 2JJ			
DRAWING TITLE			
ABOVE GROUND OFFSET FILL DETAIL			
DRAWN BY	DATE	SCALE	PAPER SIZE
DT	14.04.2022	NTS	A1
CHECKED BY	DRAWING NUMBER	REV.	
JN	13614-206	-	