

Detail 01
Jamb

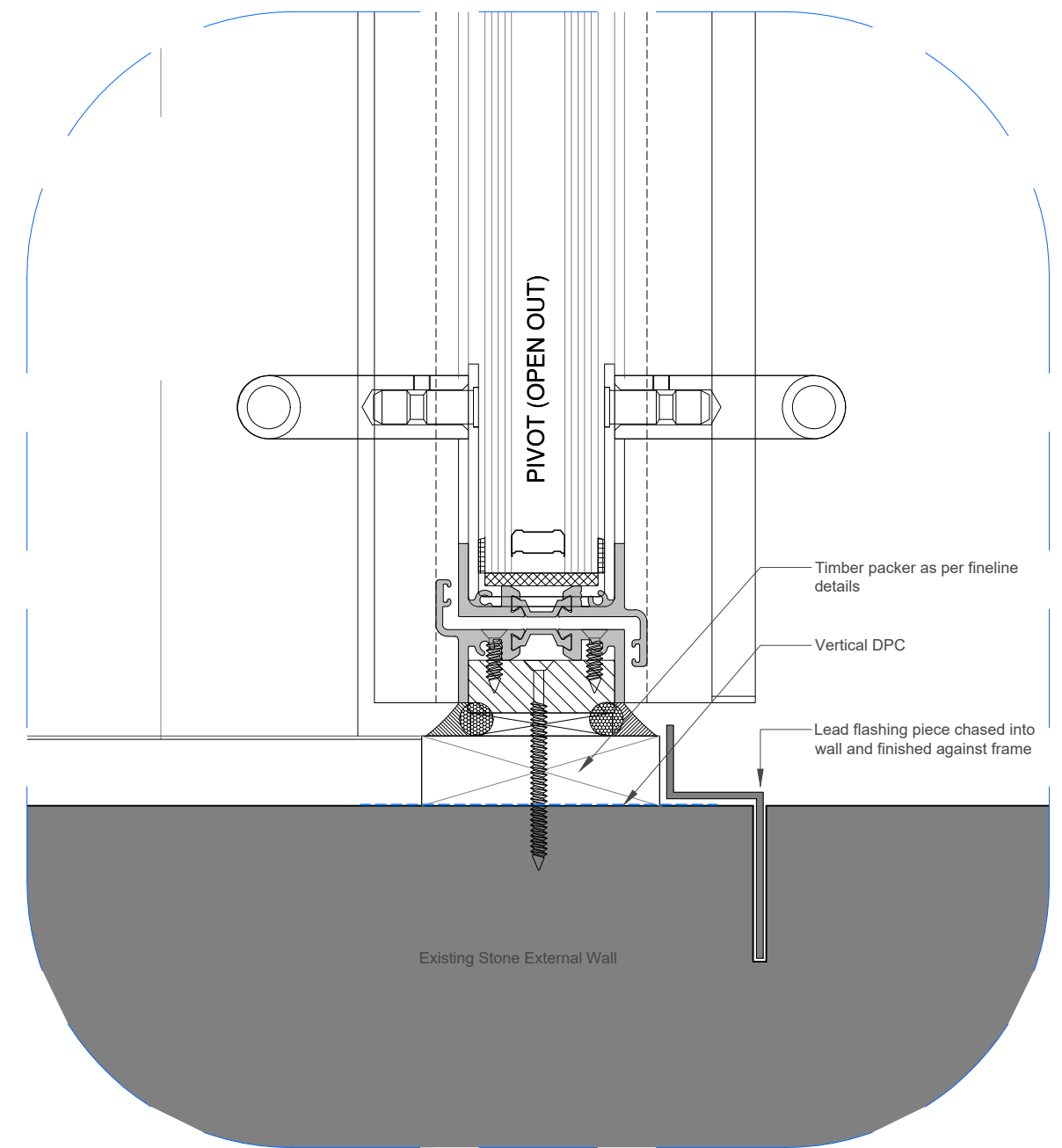

Detail 02
Flashing into existing fabric

