

017610
Commercial Bioficient 34 to 80
Wastewater Treatment Systems
Installation & Maintenance Guidelines

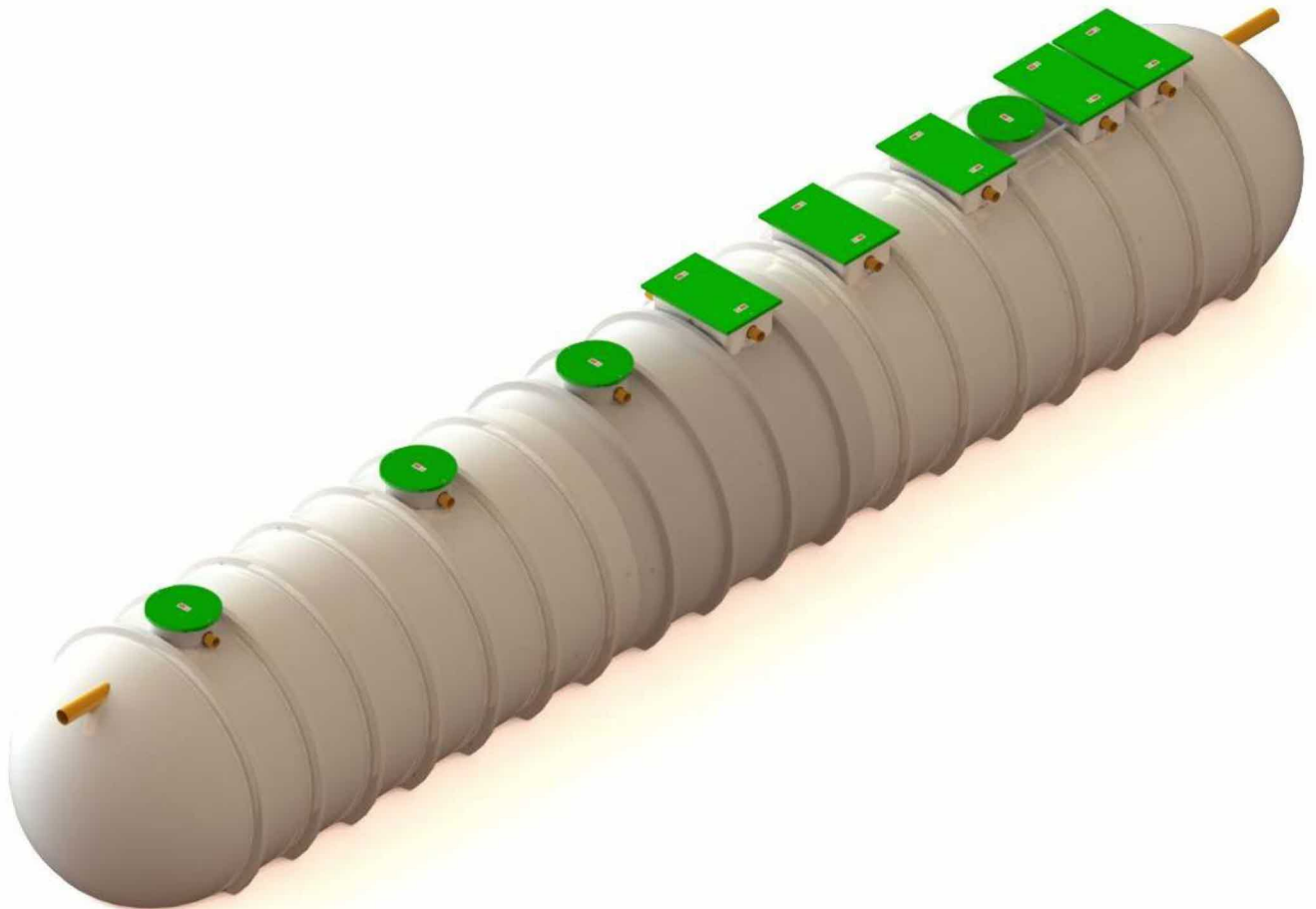

Kingspan Environmental Service Contact Numbers:

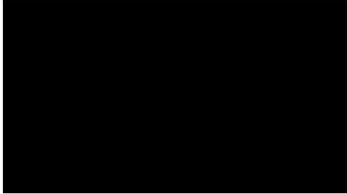

Issue:	Description:	Date:
07	CC1456	February 2019

CONTENTS

1. HEALTH & SAFETY	3
2. INTRODUCTION	4
3. HANDLING AND STORAGE	5
4. UNIT INSTALLATION	6
5. SYSTEM OVERVIEW	9
6. SITE DELIVERY CHECKLIST	10
7. SITE PLANNING	11
Concrete specification	13
8. INSTALLATION GENERAL	13
9. TECHNICAL INFORMATION	15
10. THE TREATMENT PROCESS	16
General	16
Standard effluent quality	16
Specified effluent qualities	17
Units with chemical dosing systems	17
Do's and Don'ts	18
11. OPERATION OF THE UNIT	19
General	19
Optional Pump Stations	19
Treatment Unit	19
Running Checks	20
12. MAINTENANCE	21
General	21
Units with Chemical dosing	21
Desludging	21
Maintenance Contracts	21
Servicing	22
13. WARRANTY	23
14. COMMISIONING GUIDELINES	24
Pre-installation checks	24
installation checks	24
Deep inverts	25
Chemical dosing checks	26
Electrical control panel checks	26
Going live	27
Optimising performance	28
15. FREQUENTLY ASKED QUESTIONS	29
16. CONTROL PANEL FAULT MESSAGES	31
17. BIOFICIENT NOTICE	33

1. Health & Safety

These warnings are provided in the interest of safety.

You must read them carefully before installing or using the equipment.

It is important that this document is retained with the equipment for future reference. Should the equipment be transferred to a new owner, always ensure that all relevant documents are supplied in order that the new owner can be acquainted with the functioning of the equipment and the relevant warnings.

Installation should only be carried out by a suitably experienced contractor, following these guidelines.

We recommend the use of a dust mask and gloves when cutting GRP components.

Electrical work should be carried out by only by a qualified electrician.

Sewage and sewage effluent, contaminated surface water can contain micro-organisms and substances harmful to human health. Any person carrying out maintenance on the equipment should wear suitable protective clothing, including gloves. Good hygiene practice should also be observed.

Covers should be kept locked. Do not walk on the covers. When covers are removed, precautions must be taken against personnel falling into the unit.

Alternate access covers should be selected with reference to the location of the unit and traffic loads to be accommodated. These are not part of the units supply.

Should you wish to inspect the operation of the equipment, please observe all necessary precautions,

including those listed below, which apply to maintenance procedures.

Ensure that you are familiar with the safe working areas and accesses. Ensure that the working area is adequately lit.

Take care to maintain correct posture, particularly when lifting. Use appropriate lifting equipment when necessary. Keep proper footing and balance at all times. Avoid any sharp edges.

Observe all hazard labels and take appropriate action to avoid exposure to the risks indicated. The units contain electrical items, pumps, and air lifts.

The power supply to the equipment must be isolated at the control panel(s) before lifting the covers. Where a specific maintenance procedure requires the equipment to be running with the covers off, all care must be taken to avoid contact with moving parts and electrical components or conductors.

Once power has been isolated, the control panel must be kept locked shut to avoid accidental re-connection whilst work or inspection is being carried out.

The correct ongoing maintenance is essential for the proper operation of the equipment.

The removal of sludge and liquid from the unit must be carried out by a contractor holding the relevant permits to transport and dispose of such waste. The contractor should refer to the guidelines in this document.

2. Introduction

Thank you for choosing our Bioficient, High Effluent Quality waste water treatment system. This manual will help you to keep it operating efficiently over a long service life. Please read this manual thoroughly and before installation.

This manual should be referred to by:

- a) The installer.
- b) The electrician.
- c) The maintenance engineers.
- d) The desludge contractor.
- e) The owner/user.

These Guidelines represent Best Practice for the installation of Bioficient wastewater treatment systems. Many years of specialist experience has led to the successful installation of thousands of systems. It must be noted, however, that these Guidelines are necessarily of a general nature. It is the responsibility of others to verify that they are **appropriate for the specific ground conditions and in-service loads of each installation**. Any information or advice given by employees or agents of the company in connection with the design of the installation must be verified by a qualified specialist (e.g. Civil engineering consultant).

Each Bioficient system has been individually selected to achieve the specified final effluent quality. The equipment size / system design is based on your declared required effluent quality, application and the estimated daily volume and loads for various parameters. Your quotation will have specified the incoming parameters and the final effluent quality to be obtained. You will be supplied with a control panel which includes the appropriate timed recycle settings and operations to achieve the quality specified.

Treatment takes place within a single horizontal tank which includes primary and final settlement areas as well as treatment zones. Within the system, the partially treated effluent is recycled.

When treating domestic effluents, the treatment process is designed to achieve an effluent quality with a daily average of:

20mg/l BOD / 30mg/l SS / 5mg/l NH₄N

- Some system designs may be offered to achieve lower ammonia levels.
- Some system designs may offer to achieve a daily average specified Total Nitrogen consent.

20mg/l BOD / 30mg/l SS / 5mg/l NH₄N / 15 TN

- Some system designs include a chemical dosing system to achieve alternate daily average effluent qualities such as defined phosphate levels.

Non-domestic sewage applications with specified effluent qualities are specified individually.

Standard system designs require sludge removal at intervals of approx. 90 days. Units with chemical dosing may have a decreased interval.

In the UK, Wastewater equipment selection and application guidance is provided by the Environment Agency, Pollution Prevention Guidelines PPG 4. In Ireland, guidance is provided by the EPA manuals.

You will require permission to install a wastewater treatment system and permission /consent to discharge the effluent which will probably include specified effluent qualities and a maximum volume. Consult your local authority as the installation will probably require Planning and Building Control approval. In the UK, you will need to be aware of publication DETR 3/99 (Welsh office 10/99) "Planning requirement in respect to use of non-mains sewerage incorporating septic tanks in new development" and the drainage and waste disposal building regulations H2 (2000). In Ireland, guidance is provided in circular letter SP/03 for the protection of groundwater. These documents require detailed site assessments.

Should you require information regarding the design of a drainage field or alternate system designs and sizing please contact us. Large systems treating large daily volumes require large land areas. In the UK, BS: 6297; 2007 provides drainage field designs. In Ireland, the single house EPA manual provides design guidance. Percolation test methods to identify soil suitability are slightly different in UK and Ireland, the percolation test results should be documented and retained. A building inspector may wish to examine the site before, during or after tank installation and may require sight of percolation test results.

Wastewater treatment systems are covered within the UK by H2 Building regulations 2000. Systems should have sufficient capacity to enable the breakdown of solid matter in the wastewater from the buildings, be sited and constructed so as to prevent overloading of the receiving water. They must not be prejudicial to health or be a nuisance, adversely affect any water sources or resources or pollute controlled waters. They must not be sited in an area where there is a risk of flooding. Systems must be constructed so as to have adequate ventilation and so as to prevent the leakage of the contents. They must have adequate means of access for maintenance and emptying.

Buildings which utilise Biological treatment systems should have a notice affixed within the building. This notice should advise the estimated emptying frequency and the need to use a licensed waste disposal contractor. Details of maintenance requirements are required. The owner is legally responsible for ensuring that the system does not cause pollution, a health hazard or a nuisance.

3. Handling and Storage

- Unit dimensions, connections, and weights etc. are provided on a separate drawing.
- Care must be taken to ensure that units are not damaged during delivery and handling on site. Tanks are manufactured in glass fibre reinforced polyester (GRP) which makes the tanks light in weight and easy to transport and install. The tanks can be damaged by sharp objects and point loads. The unit includes loose plastic media within three of the compartments. You must avoid rolling the unit. If there is any damage found at delivery, it should be reported to us within 48 hours.
- The design requirements of our products will frequently mean that the centre of gravity of the unit is “offset”. Care must therefore be taken to ensure that the unit is stable when lifting. If the covers have been removed, rainwater may collect inside units, adding weight and increasing instability. Check units before lifting and pump out any excess water.
- When lifting the unit, use webbing slings of a suitable specification. **DO NOT USE CHAINS.** Lifting equipment should be selected by taking into account the unit weight, length and the distance of lift required on site.
- A suitable spreader bar should be used to ensure that units are stable and that loads are evenly distributed during lifting. When lifting units, a spreader bar should be used where the slings would otherwise be at an angle > 30 degrees to the vertical.
- Whenever units are stored or moved on site, ensure that the storage location is free of rock, debris and any sharp objects, which may damage the unit. The units must be placed on ground, which is flat and level to evenly support the base of the unit evenly.

SLINGING POSITIONS

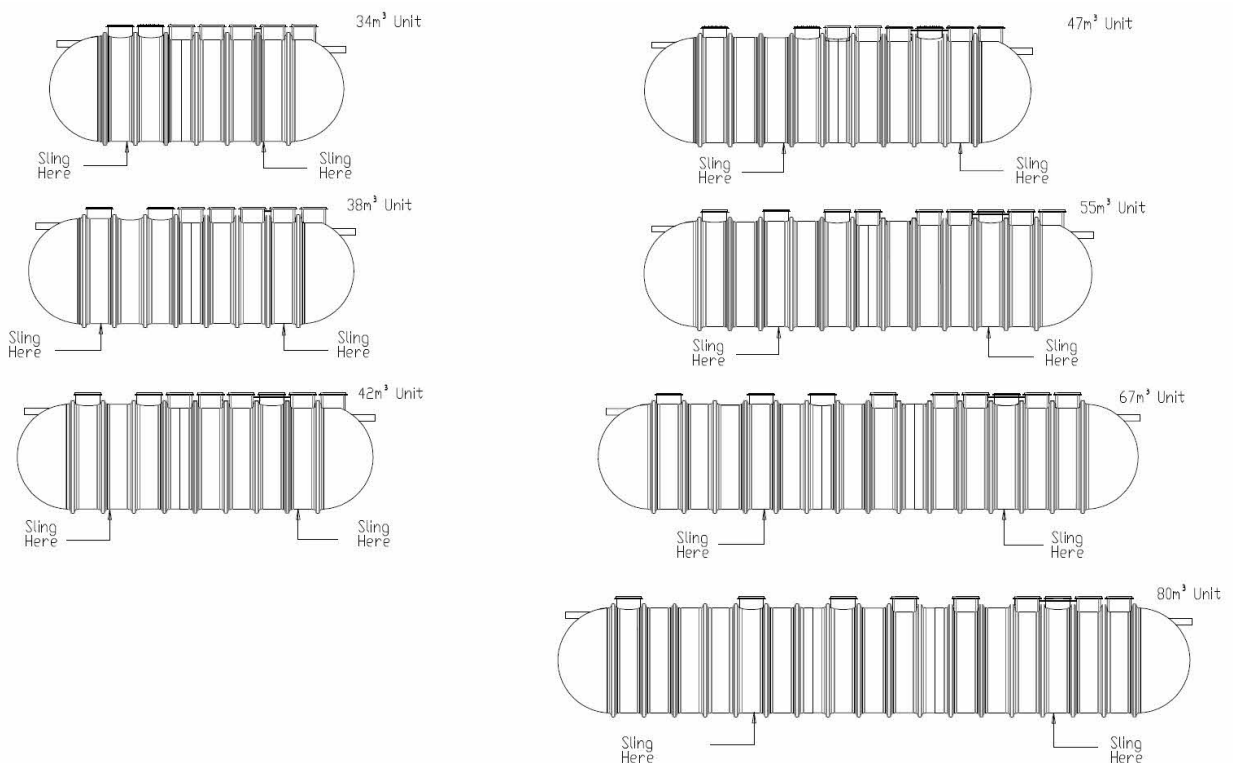

Figure 1; slinging positions (0.5m invert units shown)

4. Unit Installation

1. Do not install in trafficked areas unless a suitable top slab has been designed and constructed. The top slab should bear on a suitable foundation to prevent superimposed loads being transmitted to the unit and access turrets. Loads applied must bear on the top slab, not the access turrets.
2. See the section on “Deep Invert Units” for fitting of extension necks and manifolds.
3. Ground conditions and water table level should be assessed. If the water table will be above the base of the unit at any time of the year, adequate concrete backfill must be provided to avoid flotation. In poorly draining ground, consideration should also be given to the likelihood of flotation due to surface water collecting in the backfill. It should be borne in mind that the inlet drain trench will act as a land drain, directing surface water to the backfill around the unit.
4. Excavate a hole of sufficient length and width to accommodate the tank plus a minimum 225mm concrete surround. The depth should allow for the burial depth of the unit plus a concrete base slab of 300mm. The maximum depth to the base of the excavation must be no more than 4.7m including the base slab.
5. Construct a suitable concrete base slab appropriate to site conditions. Ensure that the slab is flat and level.
6. When the concrete base slab has set enough to support the installed load, lower the unit onto the slab using suitable webbing slings and lifting equipment. The selection of lifting equipment is the responsibility of the installer considering unit weight, length, height and distance of lift. The unit includes baffles, pumps, diffusers and other components so please note that the unit weight will not be evenly balanced.
7. Pour no more than 300mm depth of clean water into each compartment. This should be achieved simultaneously but avoid a shock load. A recommended way of doing this is to add clean water into the second biological treatment zone (which has media within it) until the level in the first primary zone (first turret from inlet) is 300mm. At the same time, fill the last turret, the final settlement zone.
8. **DO NOT OVERFILL**; the unit is not designed to hold water whilst unsupported. Place concrete backfill to approximately 300mm depth under and to the sides of the tank ensuring good compaction to remove voids. Concrete backfill must be manually compacted; WE DO NOT recommend the use of vibrating lances. ALLOW INITIAL CONCRETE SET TO OCCUR BEFORE PROCEEDING. Ensure concrete fills the voids underneath tank and ribs.
9. Continue adding concrete backfill, simultaneously keeping the internal water level no more than 300mm above the backfill level at all times, until the backfill is just below the underside of the outlet drain, giving sufficient room to connect the inlet and outlet pipework.
10. Connect the inlet and outlet drains to the site pipe work when safe access to the backfill can be gained.
11. Connect the ventilation pipes and run the pipe work to above ground level when safe access to the backfill can be gained.
12. Connect the cable conduits when safe access to the backfill can be gained.
13. Connect the three hoses to the internal diffuser assemblies via the pre-installed ducts in the necks of the tank, connect to the internal 2-inch hose tail at the top of the air diffuser assemblies, secure in place with relevant jubilee clips.
14. Run the lengths of hose through the ducting to the blower housing, cut hose to required length and connect the free ends to the outlet connections on the Blower securing in place with relevant jubilee clips.
15. Run the pre-fitted control panel flying lead (15m) with ‘quick connector’ from the internal terminal box (JB001 situated in neck of Biozone 2) through the cable conduits to the main control panel and connect opposite end of quick connector.
16. Continue backfilling with concrete over the tank body to the required level. Build up a shell of concrete, minimum 225mm thick, around the access turrets.
17. For deeper invert units (above 800mm invert) we recommend that you temporarily strut extension turrets during this procedure to avoid distortion or collapse as the necks are non-structural.
18. Continue back-filling in 300mm stages, ensuring minimum 225mm concrete thickness around the access turrets.
19. Leave until the concrete is fully cured. The unit should be left filled with clean water up to the invert level of the outlet pipe. Check that there is a discharge.
20. Replace all manhole covers.

Deep Invert Units

The standard units include fitted access turrets, however, for units with deeper inverts i.e. 1500 mm inlet inverts and above, additional access turret sections need to be site fitted.

BEFORE FITTING THE EXTENSION TURRETS, YOU MUST FIT:

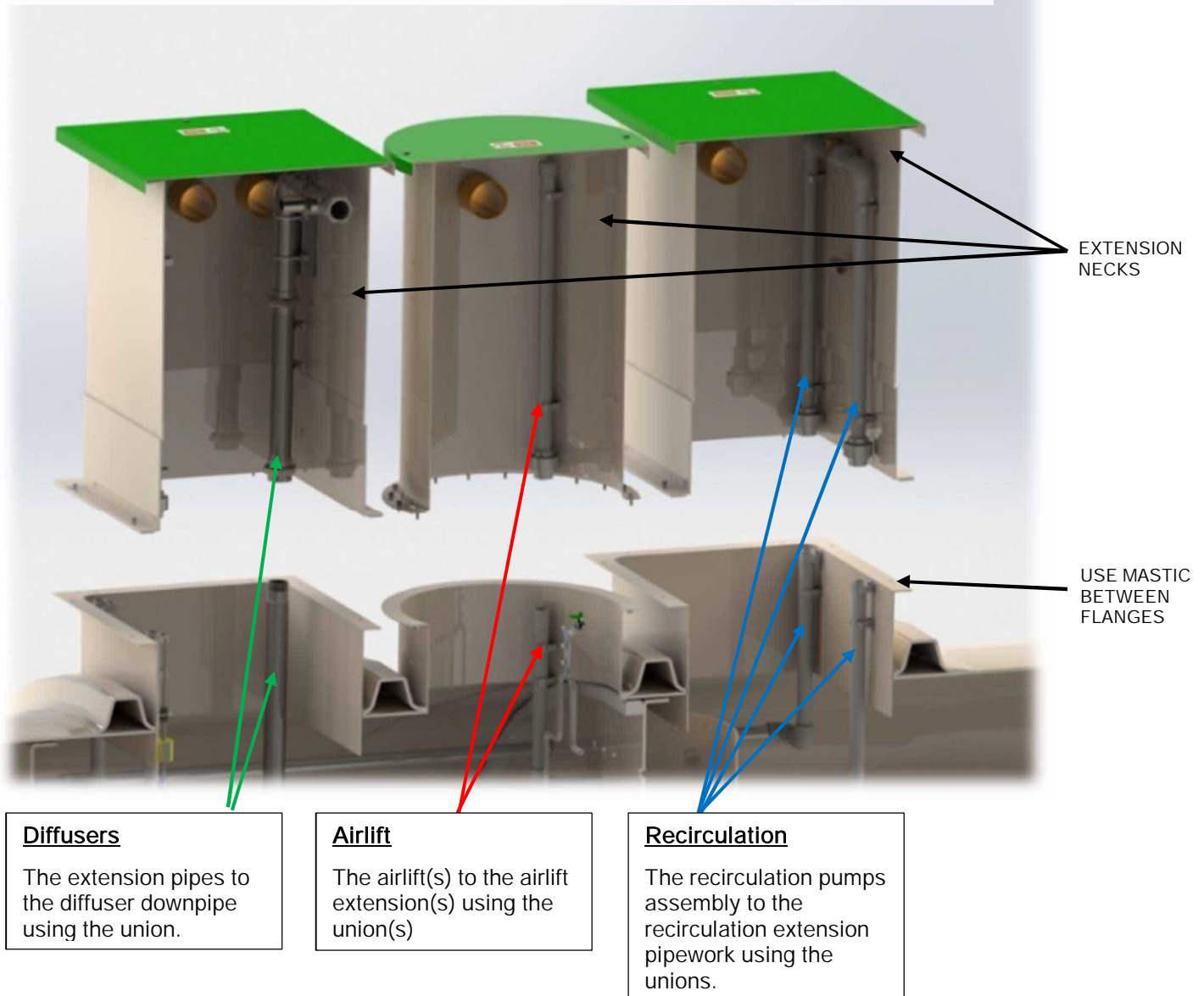

Diffusers

The extension pipes to the diffuser downpipe using the union.

Airlift

The airlift(s) to the airlift extension(s) using the union(s)

Recirculation

The recirculation pumps assembly to the recirculation extension pipework using the unions.

NOTE: Make sure that the access handle is fixed to the Effluent Filter in the FST using self-tapping screws. Refer to “Section 12. Maintenance” for illustration.

The pump cables should also be brought to the uppermost turret as installation progresses.

When the installation includes a separate structural concrete raft, it is necessary to order the extension kit to the full invert depth. The full invert depth is from finished ground level, Failure to take account of the finished ground level will mean that the internal valves and junction boxes will not be accessible for routine maintenance and servicing. This may require “confined space” entry which will significantly increase the cost of maintenance and servicing.

NB: For units with inverts greater than 800mm the wiring loom junction boxes will NOT be supplied fixed to the neck, once the extension turrets have been fitted the junction boxes should be fixed to the upper most extension pieces close to the top for ease of access.

The additional turrets are flanged. Use the mastic supplied and bolt through the flanges, from top to bottom using washers below the bolt head and above the nut. Check that the flanges are fully sealed and water tight before completing the concrete backfill around each turret.

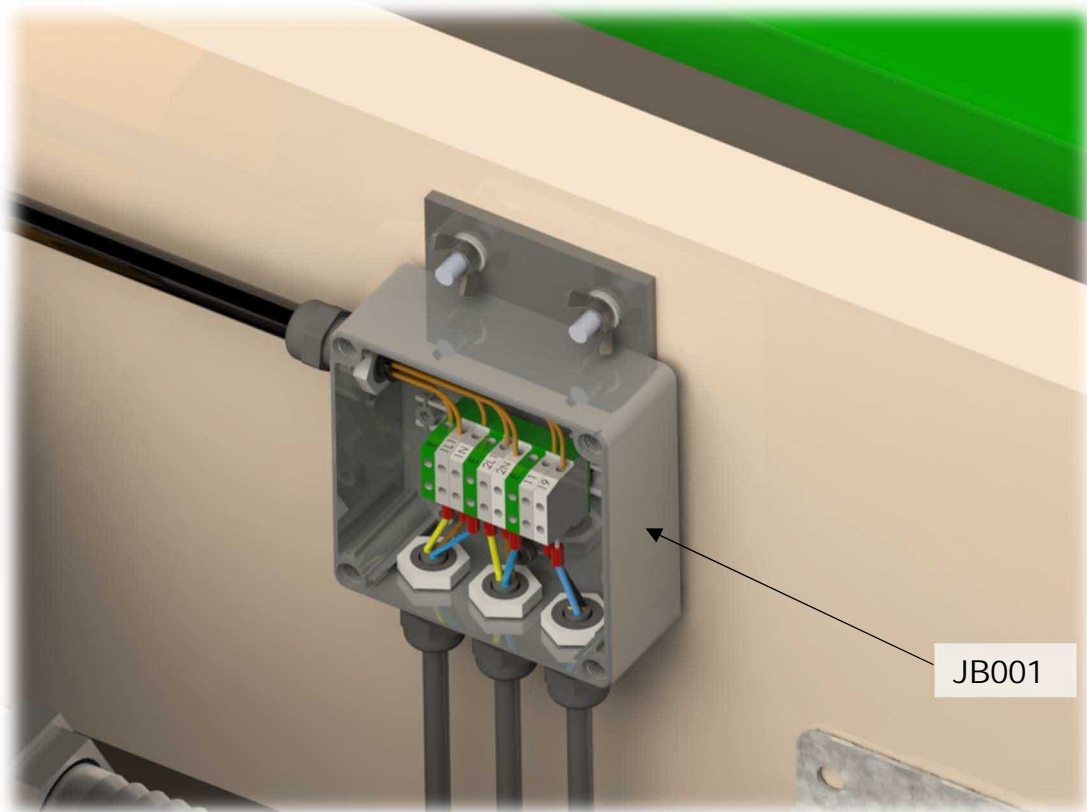

Electrical connection

Electrical work should only be carried out by a qualified electrician working to the latest electrical regulations.

The Bioficient treatment unit contains the following electrical components inside the plant, all of which are prewired to a common electrical terminal (JB001) located within one of the middle turrets:

- High Level Float.
- Recirculation Pump 1.
- Recirculation Pump 2.

The main supply blower should be placed within a suitable kiosk or brick built housing (kiosks are available to purchase as an extra item, they are NOT included in standard supply).

The blower should be fixed down to the concrete base via fixing positions supplied. NB: it is recommended that the blower is mounted on anti-vibration mounts. If the blower is housed in a kiosk, separate ventilation/cooling facilities may be required to prevent the blower overheating.

The control panel should be either mounted to the side of the constructed blower housing or mounted within a suitable kiosk (kiosks are available to purchase as an extra item, they are NOT included in standard supply).

Connecting Blower: Run cable between the blower terminal box and the Control Panel connecting the cable to the blower terminals within the control panel (see wiring diagram supplied with unit).

Connecting Internal Loom: Run the cable with quick connector (male end) from JB001 through the ducting to the Control panel kiosk. Connect the male quick connector to the female quick connector located on the base of the control panel.

Connect the control panel to the mains power supply. The wiring is complete. **Please insure you refer to the wiring diagrams provided in the control panel.**

5. System Overview.

Pictorial representation below indicates basic requirements for a standard system, please note not all of the items required are supplied from us as standard.

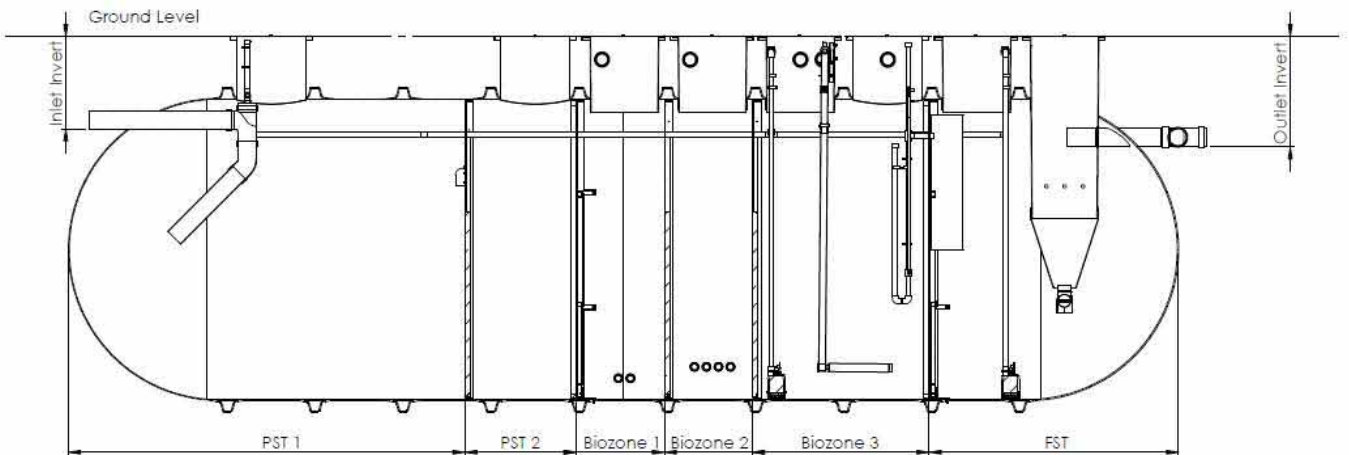
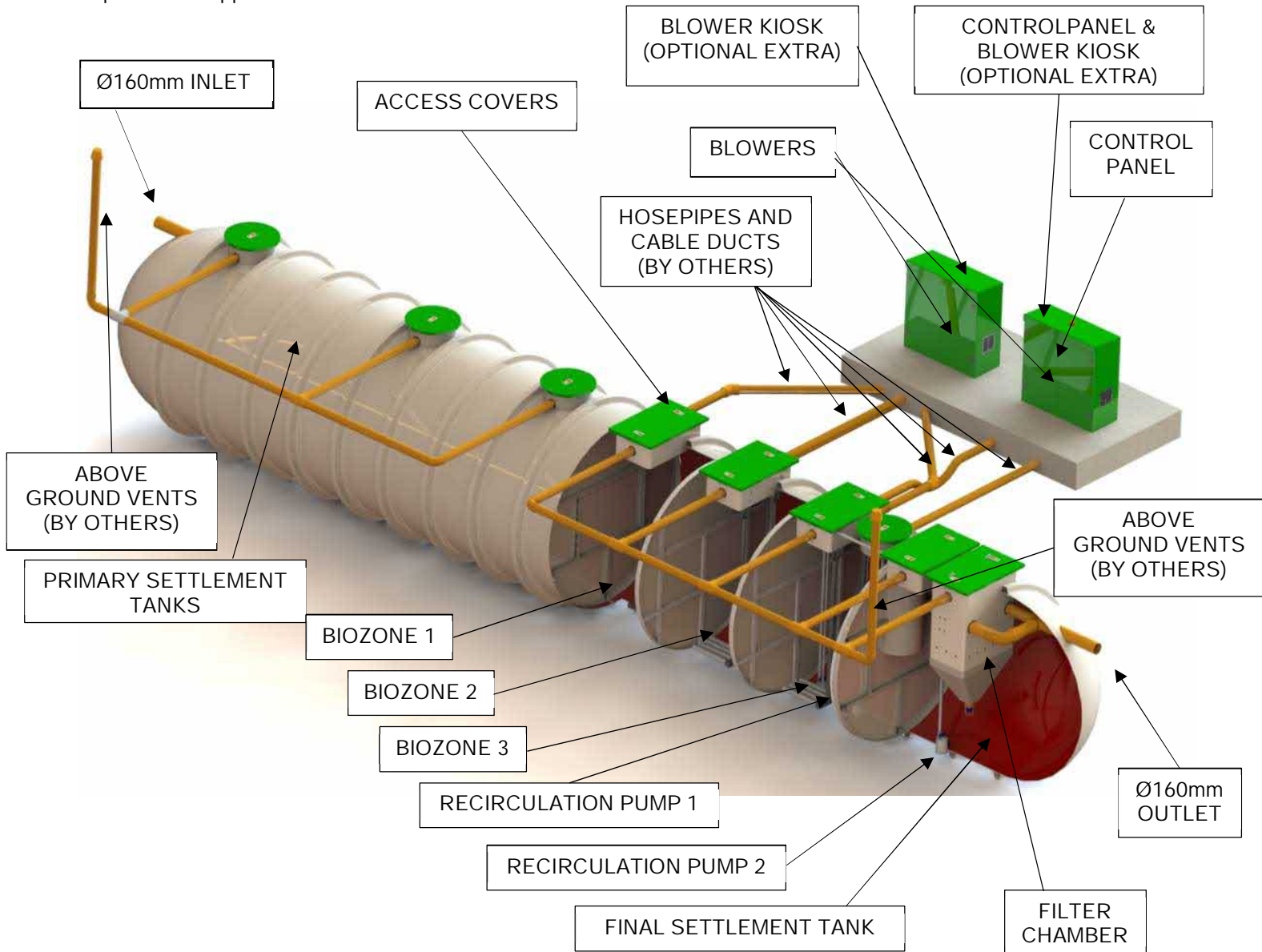
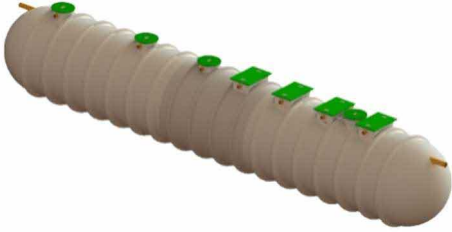
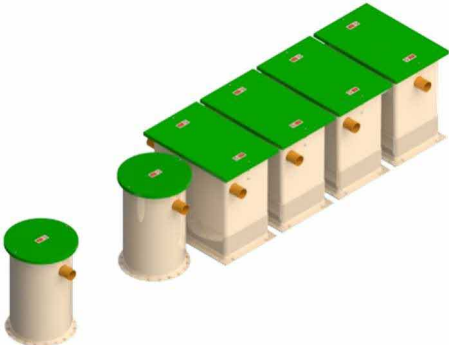



Figure 4; Typical side elevation of installed plant. 0.8m Invert shown

6. Site Delivery Checklist

The delivery checklist will have 2 or 3 module codes that will need to be checked against items actually delivered. Only 1.5m & 2.0m invert systems will have 3 module codes. Each module will be defined as described in the table below. [

<p><u>Ø2.8 GRP Chamber:</u></p> <ol style="list-style-type: none"> 1. Below ground tank assembly 2. Access covers 3. Internal wiring loom 4. Internally fitted recycle pumps 5. NB: For tanks with invert depth greater than 0.8m access covers will be included in neck extension kit. 	<p>CASE ASSEMBLY</p>	
<p><u>Extension Necks & Fittings:</u></p> <ol style="list-style-type: none"> 1. Extension Neck Kits (only required for inverts 1.5m and 2.0m). 2. Access covers 3. Mastic Kits (consisting of: 2m mastic per neck, 24qty M8 bolts, 24qty M8 nuts and 48qty M8 washers per extension neck) 	<p>NECK ASSEMBLY</p>	
<p><u>Blowers, Controls & Connecting Pipe:</u></p> <ol style="list-style-type: none"> 1. 3 x Main supply blower (For Diffusers) 2. Main supply blower (For Airlift(s)) 3. Control panel 4. High temperature hose (3 x 10m). Each hose from blower manifold connects to diffusers mounted inside the tank via pre drilled holes in neck). 5. PPFDS Hose (5m to connect the blower manifold to the control panel). 6. Clear braided hose (15m to connect the blower to the airlift mounted inside the tank via pre drilled holes in neck). 	<p>ELECTRICAL ASSEMBLY</p>	

Additional items available on request NOT standard supply (please contact our sales department for more information):

1. Kiosk to house the blowers
2. Kiosk to house the control panel
3. Final effluent pump stations
4. Sample chambers
5. Chemical storage chamber for chemical dosing units

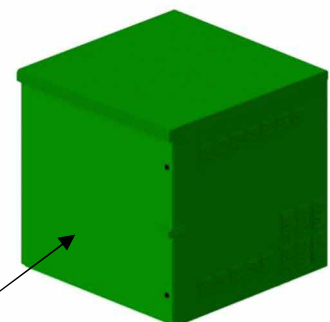

BLOWER & CONTROL PANEL KIOSKS AVAILABLE AS OPTIONAL EXTRA

7. Site Planning

The following points should be considered before installation of the equipment:

The discharge must have the consent of the relevant environmental regulator. Details of the consent should be advised to us in advance of placing an order. There will be a requirement to provide a sample chamber and there may be a requirement to provide facilities for flow measurement. (See notes below)

The installation should have planning and building control approval (See Introduction)

Position the unit at the maximum distance from habitation. For single house systems, distances in excess of 7m are usually the minimum acceptable to the planners, but this varies depending on buildings, boundaries, etc. and your local authority. Large systems, such as an Bioficient unit should be installed at greater distances. The installation must be sited so as not to be prejudicial to health, nor to contaminate water supplies.

See BS EN 752-4. Drain & sewer systems outside Buildings.

Consider placing inspection points in the drain line before and after units.

The regulator will require a sample chamber to be installed at the outlet of the treatment systems. The regulators will advise their specific requirements. They usually advise that access to the sampling point should be via a path and constructed from a firm material and on a level ground where possible. Sample chambers should be easily accessible and provide the means to take a running sample, a sample container must be able to be positioned under a protruding pipe lip which is located at a height of 200mm above the water level. (We can provide sample chambers however, some regulators may specify specific designs and other requirements). Samples, with agreement may also be taken at the inlet point of a downstream effluent pump station.

The treatment unit should preferably be installed at a level which will allow connection to the incoming drain and a free discharge at the system outlet. The system should not be installed deeper than necessary.

Units are available with inlet inverts of 0.5m, 0.8m, 1.5m and 2.0m. Selection of the correct inlet invert is key, it must be suitable for the drainage and ground levels on site, the invert CAN NOT be altered once the plant is installed. In any circumstance, the maximum allowable inlet invert is 2000mm.

Select a suitable location for the unit. This will normally be at the lowest ground level on the site so that the facilities can be drained by gravity, please consult architect.

Check that no other structure - or special access - is required at the selected position.

Provision can be made, if necessary, to place the unit in a roadway, provided that the backfill, cover slab and access cover are designed in accordance with the load requirements. Special provision to accommodate maintenance access needs to be incorporated into the design. Please contact Kingspan Sales for advice.

Check that no underground cable, pipe or service duct lies beneath the selected position.

Consider if there is a need for a pumping station upstream of the treatment unit. The treatment unit is available with a number of standard invert options. The invert must be specified at the time of order. The process design may have specified a pump station to assist in flow attenuation or to minimise the excavation required. If the site contractor has specified their own pump station, this must be advised to us at the design stage, so that we can ensure that it will not adversely impact on the process.

Systems must be ventilated with both a "local to the unit vent" and with appropriate high level vent(s) located on the building(s) served, considering prevailing wind direction. The head of the drainage system should be connected to a stack pipe, open at high level, so as to draw foul air from the system and be sited with consideration to prevailing wind direction. Tile vents & air admittance valves within the buildings should not be used as the sole high level drainage ventilation facility. All inspection points within the drain system should be sealed so as to enable ventilation at high level. If tanks or pump stations are fitted before the treatment unit, then be aware of the possibility that the high level vent may only vent these units. The Bioficient unit requires independent ventilation. Check for any local regulations.

Uncontaminated run off such as roof and surface water must be excluded from the unit. Separate drains must be provided for surface water which must NOT enter the unit.

Ground conditions and water table level should be assessed. If the water table will be above the base of the unit at any time of the year, adequate concrete backfill must be provided to avoid the unit's flotation. In poorly draining ground, consideration should also be given to the likelihood of flotation due to surface water collecting in the backfill, and an appropriate installation method devised to avoid this.

If the discharge is to a drainage field, a porosity test must be carried out as part of the assessment of suitability for sub-soil drainage. UK - See BS 6297:2007. Ireland - See EPA Manual.

There must be at least 1 metre of clear, level ground all around the access covers to allow for routine maintenance. There must be access to the unit for sludge gulpers. Vehicles should not be permitted within a distance equal to the depth of the unit, unless suitable

017610 Bioficient WWTP Installation & Maintenance Guideline

structural protection is provided when the unit is installed.

Provide separate suitable electrical supplies for the Bioficient system and any ancillary pump station. These should be RCD isolated and protected.

Proximity to a mains water hosepipe connection point is recommended, for maintenance purposes. Such a supply should be connected in accordance with water bylaws and regulations. **Never leave a hose connected and immersed in sewage.**

For discharge consents within the Environment Agencies control, we understand that for discharges above 50m³ per day, all new consents will stipulate the requirement for flow measurement. They may require flow measurement locations and devices for discharges 5-50m³ per day. You should contact the regulator for individual consent conditions and advice as to their requirements. See EA document EASD/230/1/3/27, water quality consenting standard flow measurement for discharges.

Installation should only be carried out by suitably qualified and experienced contractors in accordance with current Health and Safety Regulations. Electrical work should only be carried out by a qualified electrician, working to the latest edition of IEE.

Units are supplied with non-pedestrian duty access covers and frames.

8. Installation –General

The drawing supplied shows a general layout for a typical unit. Check the dimensions of your specific unit.

Check tank carefully before attempting to install, under no circumstances should you install a damaged unit. Check all other items are available, as identified by delivery list.

Inform us immediately, on delivery if there is any damage or shortages.

Additional items are required, (not supplied by us)

- External to the unit pipework. PVCu Inlet/Outlet, ventilation and cable/ ducting.
- Ventilation pipework
- Sample chamber
- Ventilated housing for blower either a brick built enclosure or suitable kiosk. (kiosk range available NOT part of standard supply, please contact sales department).
- Alternative special loading access covers. (Standard access covers are supplied)

When units are installed in unstable ground conditions where movement of the surrounding material and/or unit may occur, the connecting pipework should be designed to minimise the risk of damage from

differential movement of the unit(s) and/or surrounding material.

For units with burial depths greater than 800mm from invert level to the top of the unit, specific site conditions should be taken into consideration and the backfill designed to bear any loads which may be applied during and after installation to prevent the tank being subjected to these loads.

The excavation must be deep enough to provide bedding and cover depth as determined by the type of surface pavement and loading. Asphalt and concrete base pads should extend a minimum of 300mm horizontally beyond the unit in all directions.

In situations where the excavation will not maintain a vertical wall, it will be necessary to shore up the side walls of the excavation with suitable trench sheets and bracing systems to maintain a vertical wall from the bottom to the top of the excavation. DO NOT completely remove the shoring system until the backfilling is complete, but before the concrete fully hardens.

In areas where the water table is above the bottom of the excavation and/or the excavation is liable to flood, the excavation should be dewatered using suitable pumping equipment and this should continue until the installation is complete.

During installation care must be taken to ensure that the body of any unit is uniformly supported so that point loads through the unit are avoided.

Concrete Specification

The concrete Specification below is a *general* specification. It is not a site specific installation design.

GENERAL CONCRETE SPECIFICATION IN ACCORDANCE WITH BS EN 206-1 (BS 8500-1)	
TYPE OF MIX	(DC) DESIGN
PERMITTED TYPE OF CEMENT	BS 12 (OPC): BS 12 (RHPC): BS 4027 (SRPC)
PERMITTED TYPE OF AGGREGATE (coarse & fine)	BS 882
NOMINAL MAXIMUM SIZE OF AGGREGATE	20 mm
GRADES: C25 /30 C25 /30 C16 /20	REINFORCED & ABOVE GROUND WITH HOLDING DOWN BOLTS REINFORCED (EG. FOR HIGH WATER TABLE) UNREINFORCED (NORMAL CONDITIONS)
MINIMUM CEMENT CONTENT	C30 270 - 280 Kg/M ³ C20 220 - 230 Kg/M ³
SLUMP CLASS	S1 (25mm)
RATE OF SAMPLING	READY MIX CONCRETE SHOULD BE SUPPLIED COMPLETE WITH APPROPRIATE DELIVERY TICKET IN ACCORDANCE WITH BS EN 12350-1
NOTE: STANDARD MIXES SHOULD NOT BE USED WHERE SULPHATES OR OTHER AGGRESSIVE CHEMICALS EXIST IN GROUND WATER	

Typical site layout

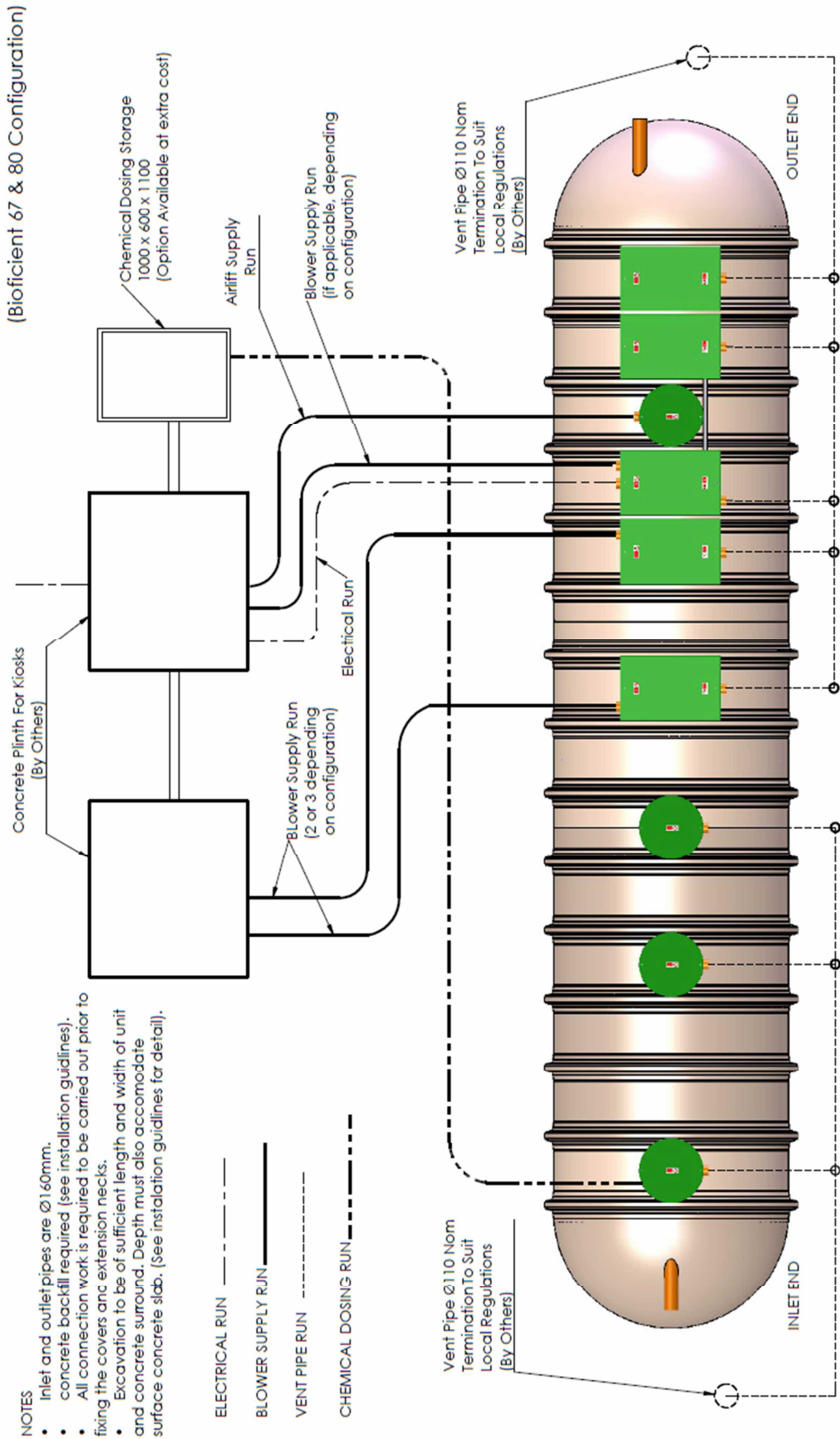

Figure 5; typical layout (shown with optional chemical dosing)

9. Technical Information

Bioficient Model		34	38	42	47	55	67	80
Max flow	m ³ / day	15	20	25	30	40	50	60
Peak flow rate for ½ hr in any 2 hour period	m ³ /hr	1.8	2.5	3.1	3.75	5	6.25	7.5
Main Blower 1 power / Full load current	Kw / A	0.18 / 1.6	0.23 / 2.1	0.23 / 2.1	0.36 / 3.2	0.45 / 3.4	1.1 / 6.62	1.5 / 10.1
Main Blower 2 power / Full load current	Kw / A	0.18 / 1.6	0.23 / 2.1	0.36 / 3.2	0.36 / 3.2	0.45 / 3.4	1.5 / 10.1	1.5 / 10.1
Main Blower 3 power / Full load current	Kw / A	0.23 / 2.1	0.23 / 2.1	0.36 / 3.2	0.36 / 3.2	0.45 / 3.4	1.5 / 10.1	1.5 / 10.1
Power supply phase		230 V Single	230 V Single	230 V Single	230 V Single	230 V Single	230 V Single	230 V Single
Recirculation Pump 1 power (on timer operation) / Power supply phase / Full load current	Kw / A	0.35 / 230 V single / 1.4						
Chemical dosing pump* power. Power supply phase/Full load current	w / Ma	5 / 230 V single / 300						
Not Supplied on ALL units								
Recirculation Pump 2 power (on timer operation) / Power supply phase / Full load current	Kw / A	0.35 / 230 V single / 1.4						

Technical Specification

Model	34	38	42	47	55	67	80
Maximum flow (m ³ /day)	15	20	25	30	40	50	60
Retention time (hrs)	46	39	35	32	28	28	27
A Overall Length (m)	7.4	8.1	8.9	9.7	11.2	13.5	15.8
B Overall Width (m)	2.8						
C Height (m)	2.8						
500mm Inlet / 650mm Outlet Invert*	2.96						
800mm Inlet/ 950mm Outlet	3.26						
1500mm Inlet / 1650mm Outlet Invert*	3.96						
2000mm Inlet / 2150mm Outlet Invert*	4.46						
D Diameter (m)	2.6						
Volume (m ³)	34	38	42	47	55	67	80
Weight approx (kg)	3000	3200	3400	3800	4200	4700	5400
Inlet / Outlet Diameter (mm)	160						

Notes:

- * Extension necks can be added to turrets to achieve deeper inverts. Alternative pipe sizes may be ordered.
- For deep installations over our standard 2m invert, we recommend an independent civil engineer advice be sourced.
- Weights are dry weights and installers must ensure there is no water in the tanks before lifting. All weights are approximate.
- Kingspan Environmental reserve the right to alter the above dimensions without prior notice.

10. The Treatment Process

General

The biological treatment process of your unit is self-regulating and it requires no specialised operational knowledge, but it is important that you are aware of the following points.

Your system uses colonies of live natural micro-organisms (biomass), to break down the pollutants in the sewage. Many chemicals used in households and commercial establishments can inhibit or kill these micro-organisms; particularly if used in excessive amounts.

Generally speaking all common household cleaning fluids are acceptable, **provided they are used in accordance with the makers' instructions and stipulated concentrations.** The golden rule is "If in doubt - leave it out". Commercial cleansing products are much stronger and some can adversely affect the biology." Please see the list of Do's and Don'ts.

Standard Effluent quality

This system process is designed to achieve a high quality effluent from a domestic sewage feed.

When loaded at its maximum rated capacity (domestic sewage BOD and ammonia), the plant design provides for a 90 days desludge interval, the Bioficient 34 & 38 provide for 120 days sludge storage.

Operation

The biological process requires the addition of power and air. Blowers, pumps, air lifts and diffusers are used to control the process; movement /recycling of liquids and solids and provide oxygen for the biological process. Within the unit there are aerobic zones, controlling aerobic biological treatment, nitrification and de-nitrification. The process energy efficiency is optimised as a result of utilising biological de-nitrification and high efficiency air diffusers.

The air supply is provided from a blower mounted remotely from the plant adjacent to the electrical control panel. Duty / Standby units or Duty / Assist configurations are available options. Single phase and 3 phase blowers can be used, please contact Kingspan Sales.

The unit is divided into a number of compartments. At the front of the unit is a large two stage compartment, the purpose of which is to provide a settlement zone for the primary solids. The settled liquid, free from gross solids, transfers through a baffle from the first to the second section of the primary compartment.

From the second primary compartment, the settled effluent passes into an aerated carbonaceous treatment biozone. This compartment contains diffusers and media. The carbonaceous biozone is followed by a large aerated nitrification biozone also with diffusers and media. Within these zones bacteria grow both on the surface of media and suspended within the liquor. The system is able to adapt quickly to a change in sewage loading and the bacterial biomasses will develop to cope with the normal daily load variations.

The system can be adjusted to perform with reduced loads (i.e. down to 50% of the specified maximum daily load) When it has been identified /agreed that this facility is required, the design modifications will have been completed pre delivery. The modifications can be made post installation to accommodate this requirement. (Site inspection charges will apply) This makes the Bioficient particularly useful for applications which expect to have periods of inactivity, such as schools, or when the loads are of a seasonal nature.

The final compartment acts as the final settlement tank (FST) where the fine solids settle. As a final filtration in the treatment plant an effluent filter is fixed to the outlet pipework. The filter is placed inside a GRP chamber with specific inlet locations to optimize the quality of the effluent entering the filter (i.e. avoid surface scum getting in contact with the filter). Effluent discharges by gravity, overflowing from the system into a sample chamber. (Optional Extra).

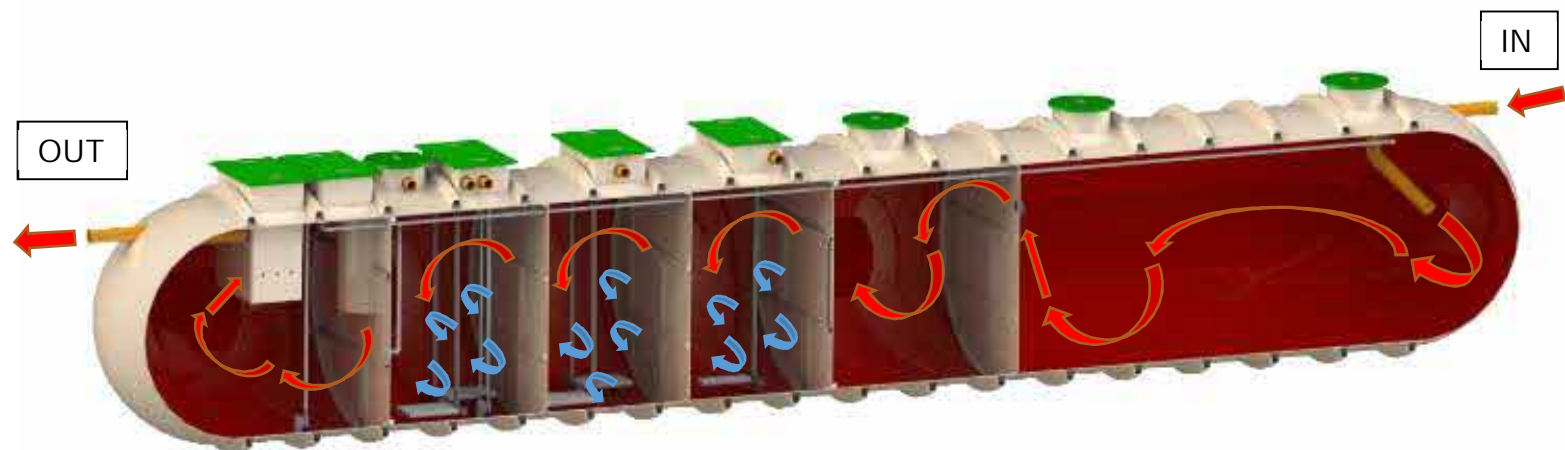

Figure 6-process flow

017610 Bioficient WWTP Installation & Maintenance Guideline

Within each compartment, the volume and liquid levels are controlled using a mixture of air lift transfers and pumped recycling. There is minimal hydraulic loss across the unit, (150mm fall). The plant design incorporates flow management to smooth out the volume and load variations and create the optimum conditions for bacterial growth.

In a gravity feed situation, in the event of a power failure, the sewage will flow into the plant, be primary settled and pass through the various zones before overflowing into the final settlement tank and out of the discharge pipe.

The system requires regular desludging from the primary and final compartments only. There is no need or requirement to empty either of the biozones. The biozones stay in operation during the period following servicing whilst the water level is restored. As a result of this, the final effluent quality remains consistently good.

Users should be made aware that their sewage enters a biological wastewater treatment system so that they can dispose of their waste considerately. Not everything is suitable for disposal into the system, for example where the unit serves premises with a catering function, special arrangements should be made to prevent the oils, fats and grease from entering the unit. Disinfectants, weed killers, medicines, brewers cleansing chemicals etc. can all adversely affect the biological process. Please request User leaflets which provides detailed information for individual householders.

Domestic and other properties feeding into the system should display a label within the building identifying use of a treatment system. See introduction notes. We can supply copies of the labels for use at individual properties.

Specified effluent qualities

Other parameters such as a Total Nitrogen or phosphate may have been specified. (See your individual quotation for effluent qualities) in which cases, additional processes may be employed.

The design will be tailored for each application to suit the expected daily incoming volume, the advised influent level and the required effluent quality. This information is provided separately or within the electrical panel settings.

Units with Chemical Dosing systems (if fitted)

Please note –The dosing chemical must be supplied by others, and is not included as part of the treatment plant order.

The reduction of phosphate is sometimes required by the environmental regulator in order to protect the local environment. The addition of limiting nutrients such as phosphate can cause eutrophication in the receiving water.

Units provided to meet effluent qualities with low phosphate discharge are provided with a chemical

dosing system. The equipment provided includes a chemical dosing pump, and a timer/control is incorporated into the system panel to allow for the regular addition of chemical. The chemical used may be specified by the regulator. Our systems may be used with liquid ferric chloride, feral, or similar, or poly aluminium chloride such as Kemira XL60. For more stringent effluent quality further treatment may be required with separate dosing pumps and tanks.

You should select an appropriate location/storage facility for the chemical selected for use.

*Design of the chemical storage facility needs to take into account the type and estimated volume of chemical used, the purchase frequency and supply unit, i.e. 25litre drum or IBC container. The design should also consider safety access and the storage requirements for the chemical chosen. Please ensure that you have the most up to date versions of the COSHH and health and safety data sheets of the selected chemical from the chemical supplier and that you observe all health and safety precautions. * The location should be made secure and be locked.

The volume of chemical dosed can be adjusted, as can the interval between the doses. The chemical dosing point is located in the first neck into the primary settlement zone to enable good mixing of the chemical with the incoming liquid. The chemical pump is usually mounted with the storage area designated for the chemical drums. This must not be too far away from the PST and the chemical line must be protected. The chemical is intermittently pumped into the dosing point positioned in the primary settlement zone. The chemical mixes with the dissolved phosphate and coagulates together to form settleable particles.

Use of a chemical significantly increases the sludge production from a unit and decreases the desludging interval.

Addition of the chemical is fundamental to the process and it is important to check the chemical usage and ensure continued availability replacing supplies before they are exhausted. Should the chemical run out, or there is no power, there will be no phosphate removal.

Customer Information- Detergents and chemical products used by consumers within the properties using the treatment plant should be selected with care so as to **reduce the amount of added phosphates** going into the treatment plant. It is possible to reduce the amount of phosphates entering the unit by up to 50%. The less phosphate entering the plant, the lower the chemical dose required.

Your unit will be provided with timers pre-set, however, you must contact us with influent phosphate readings and the chemical proposed for use, so that the unit timers can be set up to optimise dose rates and effluent quality. An extra inspection visit is required after a month's operation.

Do's and Don'ts

Domestic products

Washing machine and dishwasher detergents, washing up liquids:

These are generally all right to use in the normal concentrations and usage found in domestic housing applications but when chemical dosing, they should be chosen with care to avoid un-necessary addition of phosphate. All commercial applications should be individually assessed before installation for their laundry load. Please contact us for advice if any changes are contemplated e.g. addition of extra laundry facilities.

Floor cleaners, disinfectants and bleaches:

These are safe to use in accordance with the makers recommendations and in the minimum necessary quantity and concentration. Do not pour neat disinfectant or bleach down sinks or outside gullies. If these are smelly it usually indicates a build-up of decaying material, fat or a plumbing problem and should be dealt with accordingly.

Nappy disinfectants and bottle sterilising fluids. e.g. Milton:

When disposing of the used fluid, ensure that it is well diluted with water. The easiest way of doing this is usually to flush it away down the toilet.

Waste disposal units:

These should not be used. Their use has not been considered when designing the process. They do not inhibit the biomass, but, depending on their use, they can present the treatment plant with considerable extra load and solids. This can result in the treatment process becoming unbalanced, leading to problems. It is much better to compost vegetable peelings etc - it's cheaper and environmentally friendly.

Home beer and wine making.

This presents a similar problem to waste disposal units. The unit has to work as hard to treat one pint of beer tipped down the drain as it does to treat all the normal waste produced by one person in 24 hours. See also the notes above regarding sterilising fluids.

THE FOLLOWING MUST NOT BE DISCHARGED INTO THE DRAINS (This is not an exhaustive list!):

- Cooking oil and fat.
- Chemical Toilet Waste
- Motor oil, grease, anti-freeze, brake fluid etc.
- Weed-killers, insecticides, fungicides and other gardening chemicals.
- Paint, thinners, white spirit, turpentine, creosote etc.
- Medicines -Take unused medicines to a pharmacist for safe disposal.
- Photographic developing fluids and chemicals.
- Strong commercial cleansing chemicals, e.g., products for cleaning beer lines, drain products.
- Nappies, nappy liners, sanitary items, fabric wipes, rags, soft toys, tennis balls etc. Although such items are not directly damaging to the biomass they can cause problems, not the least of which is simple blockage of the drains. Even so-called disposable nappies and sanitary towels often do not degrade fully in the treatment plant and can lead to malfunction, so it is best to dispose of them by other means.

11. Operation

Treatment Unit

General

Every care is taken to ensure that all mechanical components are correctly fitted and adjusted prior to leaving the factory. However, subsequent handling during transportation and installation may result in the movement of components and an alteration of valve settings causing a need to re-adjust prior to starting the unit. If, on inspection, you consider that any components require adjustment, please contact us. We consider that it is essential that these units are properly commissioned by us before use.

After installation, the unit should have been left full of clean water. Power should be connected to the control panel, pumps, unit and any ancillary equipment.

Power should be left OFF, pending our inspection . Please contact us to arrange Pre-service Inspection Agreement

Should you choose to start up the system without using our services, the following notes are provided for assistance however, in providing these, we have assumed that your contractor has correctly installed, connected and tested all the equipment correctly.

Optional Pump Station

Check that the pumps have been installed and wired to the Pump Control Panel.

Check that the Pump Control Panel timer is set correctly. Our pump stations are usually supplied with a separate control panel, but in some instances, we may supply a single control panel to operate the treatment system and pump station)

Check the setting of the floats in the pump chamber.

Ensure that the float(s) can operate freely without risk of entanglement.

Influent pumps should be set to pump little and often in order to spread the load entering the treatment unit. Direct pumping into the unit should be avoided by using an external upstream discharge point. (Please consult us for further parameters)

1. Check that the unit is full of water to the outlet level.
2. Check that the manual diffuser valves and the forward feed air lift valves are fully open.
3. Adjust the forward feed airlifts to the required average normal daily flow by measuring the flow rate at the sampling point.
4. Switching the main panel on will start the blower and will initiate the timed operation of the internal pumps and any connected ancillary items, (e.g. chemical dosing pump).
5. Check that the air coming from the diffusers is moving the media.
6. Check that the high level alarm is active if the water level is high enough to flow through the overflow into the FST. Adjust the float height accordingly.
7. Allow sewage to enter the unit, this will gradually displace the clean water used during installation.

The colonisation by micro-organisms will commence naturally and a full operating biomass will establish itself within the biozones in 4-8 weeks, depending on individual site circumstances.

During start up the plant may generate some foam as the bacteria build up. This will subside as performance improves

Forward feed air lifts; maximum settings in table below.

Where two air lifts are provided, it is the combined flow rate.

Bioficient Model	34	38	42	47	55	67	80
Flow lpm	22.8	30.6	38.2	45.8	61.1	76.4	91.7

Running Checks

The following periodic checks should be carried out monthly. Your attention is specifically drawn to the Health and Safety section of this manual.

Sounds- Learn what is normal and abnormal from a sound point of view, i.e. normal blower noises and bubbling.

Looks- Visually check the general condition of the plant. Report any aspects of concern to your maintenance engineer. Know what the bubble pattern should be.

Levels- The front section is usually lower than the final tank, but this level fluctuates.

Biomass Development- Look within the biozones. There should be even turbulence with bubbles all over. The liquor may appear light grey to dark brown. The second biozone may appear a little browner.

Mechanics - Visually check that all the forward feed air lifts are operating. (Clear any debris from pipes if there is a lack of flow).

Timing Check that the pumps operate at their prescribed times and durations. Each time the power is turned on the pumps will initiate the run cycle.

Alarms Check the alarms operate. Switch off the blower but not the power to the control panel. If the alarms do not operate properly, contact your maintenance engineer.

Chemical dosing Check the level of chemical in the chemical drum and the operation of the pump at the specified dosing time and interval. The dosing does not operate at low primary tank levels.

12. Maintenance

General

The system operates with air blowers, pumps and airlifts.

Blowers will require checking regularly and will require filter cleaning and replacement.

Air lifts must be checked to ensure that they are performing correctly, delivering the correct volume and have not become blocked.

Pumps are operated using timers. Periodically pumps will need to be removed and their orifices checked for blockages.

It is recommended that the effluent filter (connected to the outlet pipework) is cleaned at every service visit.

Units with chemical dosing

Replacement of the chemical containers is required before the chemical runs out.

The chemical dosing lines should be checked each time the chemical container is replaced.

The dosing action should be checked when the container is replaced.

Excess solids are created by using the chemical. Units with chemical dosing systems will require desludging more often than standard units without the addition of chemical.

Desludging

The system requires emptying periodically. When operating at the normal daily load, emptying should take place at 90 day intervals. Bioficient 34 and 38 provide for 120 days sludge storage.

The frequency of sludge removal is expected to increase if the unit is chemically dosed. The volumes to be removed from each unit are given in the table below. Units which are over utilised may require more frequent emptying. Units which are not emptied will accumulate excess solids within the compartments. Final solids will be released and contribute to poor effluent qualities, run the risk of blocking any associated drainage field and contribute to pollution.

Different allowances/calculations should be made for non domestic inputs such as pubs and other commercial premises. Please contact us for an assessment.

DO NOT EXTEND THE EMPTYING FREQUENCY

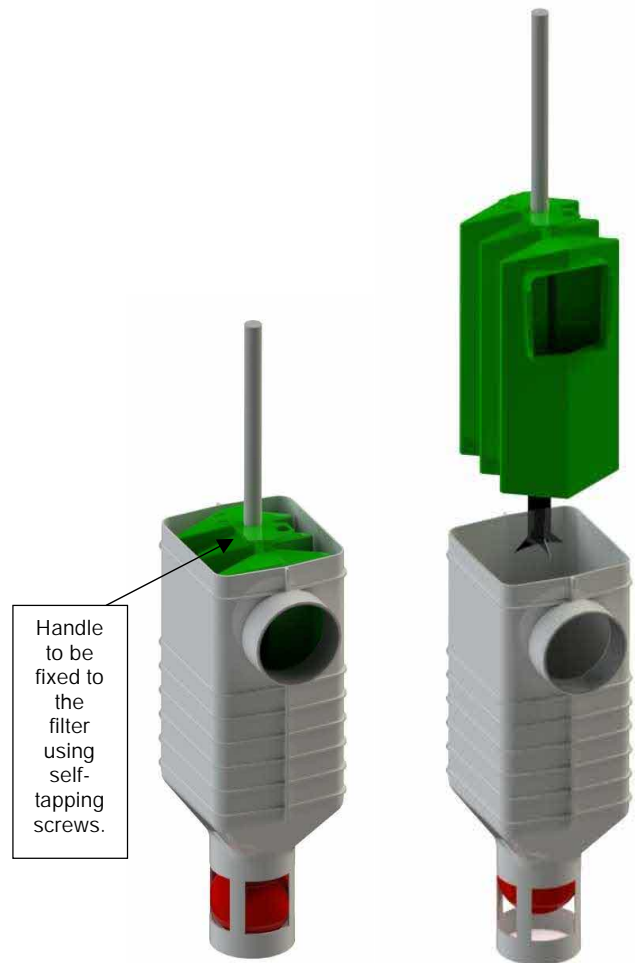

Maintenance - Effluent Filter

1. Pull the filter cartridge out of the filter housing by pulling the handle (the ball will float up and seal of the inlet of the filter housing while the filter is being cleaned).
2. Hose off filter over the Final Settlement Sone/Final compartment. Make sure all solids fall back into the treatment plant.
3. Insert the filter cartridge back into the housing making sure the filter is properly aligned and completely inserted.

Maintenance Contracts

We recommend and can provide regular planned maintenance visits to inspect the operation and performance of the units. Please contact us for details

Desludging Procedure

The two-stage primary zone should be de-sludge to remove the floating scum and approximately 60% of the volume. The FST requires the floating surface sludge to remove along with 50% of its volume. See table below for volumes.

1. Isolate power at the main control panel.
2. Remove access covers from the first, second, (in some cases third) and last access points.
3. Remove the floating surface scum from the final settlement tank. (last access point).
4. Place desludging nozzle into the base of the tank and withdraw the volume indicated, taking the settled sludge rather than the supernatant liquor. Note. Please avoid the location of the pump connected by fixed pipework from the base of the compartment.
5. Remove the floating surface scum from the first and then second compartments of the primary settlement zone (first and second access points)
6. Place desludging nozzle into the base of first compartment tank and withdraw 80% of the advised volume, taking the settled sludge rather than the supernatant liquor. Take any settled sludge from the base of the second compartment up to total volume indicated.
7. **DO NOT REMOVE LIQUOR FROM ANY OF THE OTHER COMPARTMENTS. (THESE MUST NOT BE EMPTIED AS TO DO SO REMOVES BOTH THE BIOMASS AND THE MEDIA)**
8. Replace all the access covers and secure.
9. Switch on power at the main control panel.
10. Allow sewage to enter the first compartment as normal, only if supplied by a pump station. Note. Level switches on the recycle pumps will prevent their operation until a satisfactory liquid level has been reached.

Bioficient Model	34	38	42	47	55	67	80
FST plus scum layer							
litres	4,700	4,100	6,400	5,700	5,300	8,700	8,000
gallons	1,035	900	1,400	1,250	1,160	1,910	1,750
PST plus scum layer							
litres	8,900	11,700	11,700	14,700	17,400	23,000	28,300
gallons	1,950	2,570	2,570	3,230	3,820	5,050	6,220
Total Volume to be removed per visit							
litres	13,600	15,800	18,100	20,400	22,700	31,700	36,400
gallons	2,985	3,470	3,970	4,480	4,980	6,960	7,970

Note

- A log should be kept recording the frequency of emptying.
- The waste should be removed under the terms of The Waste Management Code of Practice. The Code imposes a duty of care on the waste producer to ensure that the Cleansing contractor is registered with the Environment Regulator and that the final disposal of the waste is to a licensed facility.

Servicing

Our site engineers are available to carry out Pre-service Inspection Agreement, service and maintenance visits. We recommend regular maintenance contracts for these units. We offer a service to supervise tank emptying. Contact details are provided on the cover sheet.

13. Warranty

Taken from 'Kingspan's Terms & Conditions of Sale'

The company will replace or, at its option, properly repair without charge any goods which are found to be defective and which cause failure in normal circumstances of use within a period of twelve months from the date of delivery.

This warranty is conditional upon:

- (a) the Buyer notifying the Company of any claim within Seven days of the failure becoming discernible.
- (b) the Company being allowed a reasonable opportunity to inspect the goods so as to confirm that they are defective.
- (c) the goods not having been modified, mishandled or misused and being used strictly in accordance with any relevant instructions issued by the Company.

The Company's liability under this Clause is limited to the repair or replacement of the defective goods, and does not cover costs of transport, installation or associated site costs, if applicable.

The Company's liability to replace or repair the goods is in lieu of and excludes all other warranties and conditions, and in particular (but without limitation) the Company shall have no liability of any kind for consequential loss or damage.

For any further advice, please contact us.

A Warranty Form is included in this package, to register your unit for Warranty. Please complete ALL sections of the Form, and return it at your earliest convenience.

Our service provider: Kingspan Environmental Services [REDACTED]

14. Commissioning Guidelines

1. PRE-INSTALLATION CHECKS

On arrival check the following:

- Is the installation pack, electrical and mechanical drawings, instructions and Owners pack on site and readable?
- Do the above information packs refer to the installed treatment plant?
- Is the tank correctly installed and backfilled to permit safe access?
- Are the electrical connections to the panel complete?
- Is the mains power wired in to the panel isolator?
- Is there suitable access to switch on the mains power at the customer's supply?
- Are the air connections between the blower and the treatment plant terminated correctly?
- Are the cable/air hose ducts sealed at one end to prevent foul air being drawn from the treatment plant to the air blower or the electrical control panel?
- Are the ventilation ducts installed and run to suitable external vent positions?
- Is the sample chamber installed, or other means of obtaining a final effluent sample to set up forward flow rates?

2. INSTALLATION CHECKS

Remove the covers from the Treatment plant and check the following:

- Are the plant internals correctly located, they may have moved in transit?
- Is there any obvious debris which has entered the tank during installation which requires removal?
- Does the tank, access necks and extensions show any signs of distortion as a result of ground pressure?
- Are the air hoses correctly terminated with hose tails and the worm drive clips tightened such that the hoses are not able to be turned on the hose tails? Are the hoses neatly tied back?
- Are the air valves on the air manifolds to the diffusers all open?
- Is the forward feed air lift air tap closed? There are twin forward feed air lifts on larger plant!
- Is the air tap accessible, it may be necessary to tie it up in a suitable position to enable adjustment without stretching into the tank,
- Is the water level in the tank within approximately 300mm of the outlet invert? If NOT, arrange for more water in order to enable the treatment plant to be turned on and commissioned.
- Are the internal pumps (final settlement tank and final biozone) wired up to the internal junction boxes? On 1.5m and 2m inverts these pumps must be fitted with the extension pipework, then the extension shafts are fitted, and finally the pumps are wired in to the junction boxes.
- Is the high level alarm float switch at a high level in the tank? (To avoid early alarm whilst the tank is at a normal operating level). On 1.5m and 2m inverts the high level alarm needs to be fitted and wired into the junction box after the extension shafts have been fitted.
- Is sewage flowing into the tank?

3. DEEP INVERTS

Deep invert installations with extension necks check these items (otherwise move to step 4)

- The air diffuser extensions and the pump discharge pipework extensions should be built up before fitting the extension necks.
- Ensure that the diffusers are lined up “front to back” otherwise they will rest on the curved tank wall and may not fit on the manifold.
- Only position diffusers when there is sufficient water in the tank to cause the media to float.
- The internal wiring on deep invert plants should be completed on site with the junction boxes mounted high in the necks to enable reasonable access.
- The internal pumps require wiring in to the junction boxes.
- The high level alarm needs wiring in to the junction box, normally open in the down position, cores brown and black.

ENSURE BOTTOM OF HIGH
LEVEL ALARM FLOAT RESTS
APPROXIMATELY 50mm
ABOVE OUTLET INVERT
(NORMAL WATER LEVEL)

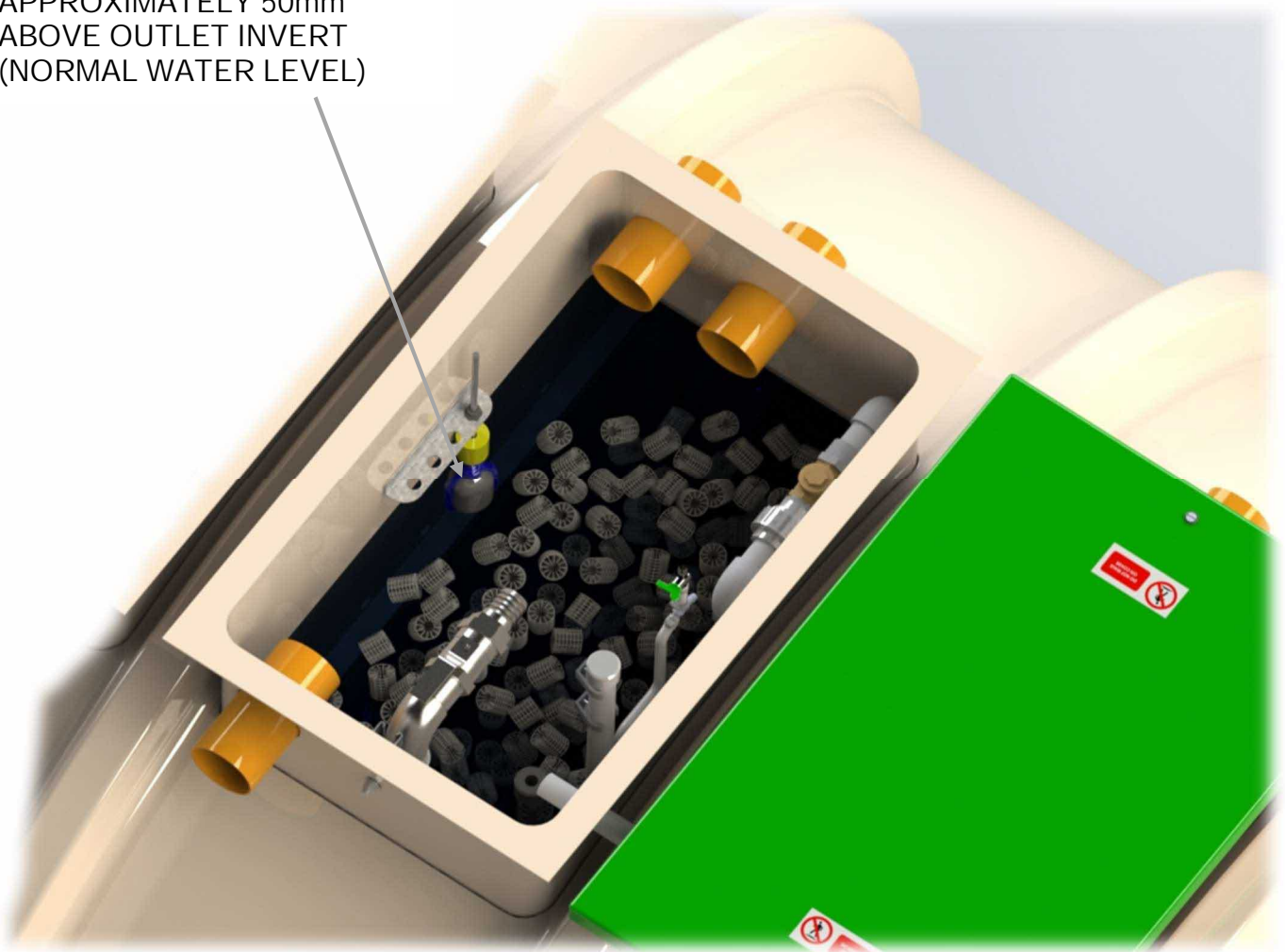

4. CHEMICAL DOSING CHECKS

Items to check for chemical dosing for phosphorus control, if fitted (if not fitted, move to step 6)

- The chemical to be used is potentially dangerous.
- The supplier will provide a Material Safety Data Sheet (MSDS) for the product. A copy of this must be kept with the other drawings provided with the plant (ideally kept adjacent to the electrical control panel) and also a copy should be given to the person in control of the premises.
- The dosing system should be wired in to the junction box with the pump box mounted in the Chemical store. The delivery hose should be run to the dosing position which is in the first neck in the First primary settlement zone.
- The chemical store must be able to be locked to prevent any unauthorised access, especially where children might be present.
- The level of the chemical in the chemical store needs to be below the dosing point to prevent siphoning, resulting in over dosing.
- Test the chemical dosing settings with water to ensure correct performance.
- Wearing appropriate personal protection equipment, open the chemical dosing container and insert the suction hose. Cutting the hose on the angle and tying the end to a stainless steel nut or bolt will keep the end of the suction pipe at the bottom of the container and prevent the hose from “sealing” onto the base of the container.

5. THE ELECTRICAL CONTROL PANEL CHECKS

All checks should be made by a suitably qualified competent person

- Is the panel mounted in a suitable location which is protected from the environment? Is access to the panel restricted to prevent unauthorised operation?
- Are the cables correctly and safely terminated?
- Is the earthing protection suitable for the installation, has it been checked?
- Are the wiring diagrams available inside the panel?
- Are the motor overloads set to the run position; they are delivered in the tripped position?
- Has the PPFDS impulse tube been run to the panel, when supplied?
- Is the remote alarm beacon wired in, when supplied?
- Replace any wiring diagrams
- Refit the cover to the panel enclosure.

6. GOING LIVE

- Is there any reason that the power should not be turned on? (Is there sufficient water in the plant?)
- If safe to do so, turn on the mains electricity supply at the customer's end.
- Turn on the mains isolator on the control panel.
 - The motors will start immediately unless there is a delay timer.
 - The panel display will illuminate, is it showing any alarms? Refer to the Guidelines for the Alarm display explanations.
- Check the first manhole on the plant (Primary tank first stage), is the recirculation pump discharging?
- Check the 3rd, 4th and in some cases the 5th manhole (the biozones), is the liquid and media being agitated and having the appearance of a vigorous boiling? Is the mixing similar in all biozones?
- When the plant is reasonably full, set the forward flow air lifts to give an average forward flow equal to the expected daily flow of sewage. Flow measurement is taken at the sample chamber or other suitable point where a container can collect the flow over a short period of time measured with a watch with a second sweep or a stop watch.
- On some plants it is possible to remove the forward feed air lifts and to turn them around so they discharge back into the biozone. This enables the forward flow rate to be set in the event that access to a suitable sampling point is not available. Once the forward flow rate has been set, the forward feed air lifts should be remounted in their normal operating position without moving the green air taps.
- The green air taps will be almost shut in most cases, if the air taps are left fully open they will starve the biozones of air, reducing or even stopping any mixing, resulting in no biological treatment.
- Check the blower operating temperature and ensure adequate cooling is available. Increase the cooling ventilation if required, natural or forced ventilation as necessary. Ventilation selection may need to take account of local noise restrictions.
- If all satisfactory, replace the manhole covers and screw down as appropriate.
- Replace all documentation and hand the Owner's Pack to the installer/customer
- Close the Kiosk/room where the electrical panel is situated.

DIFFUSER VALVES ARE DELIVERED CLOSED. THEY WILL HAVE TO BE ADJUSTED TO ALLOW MIXING IN ALL BIOZONES

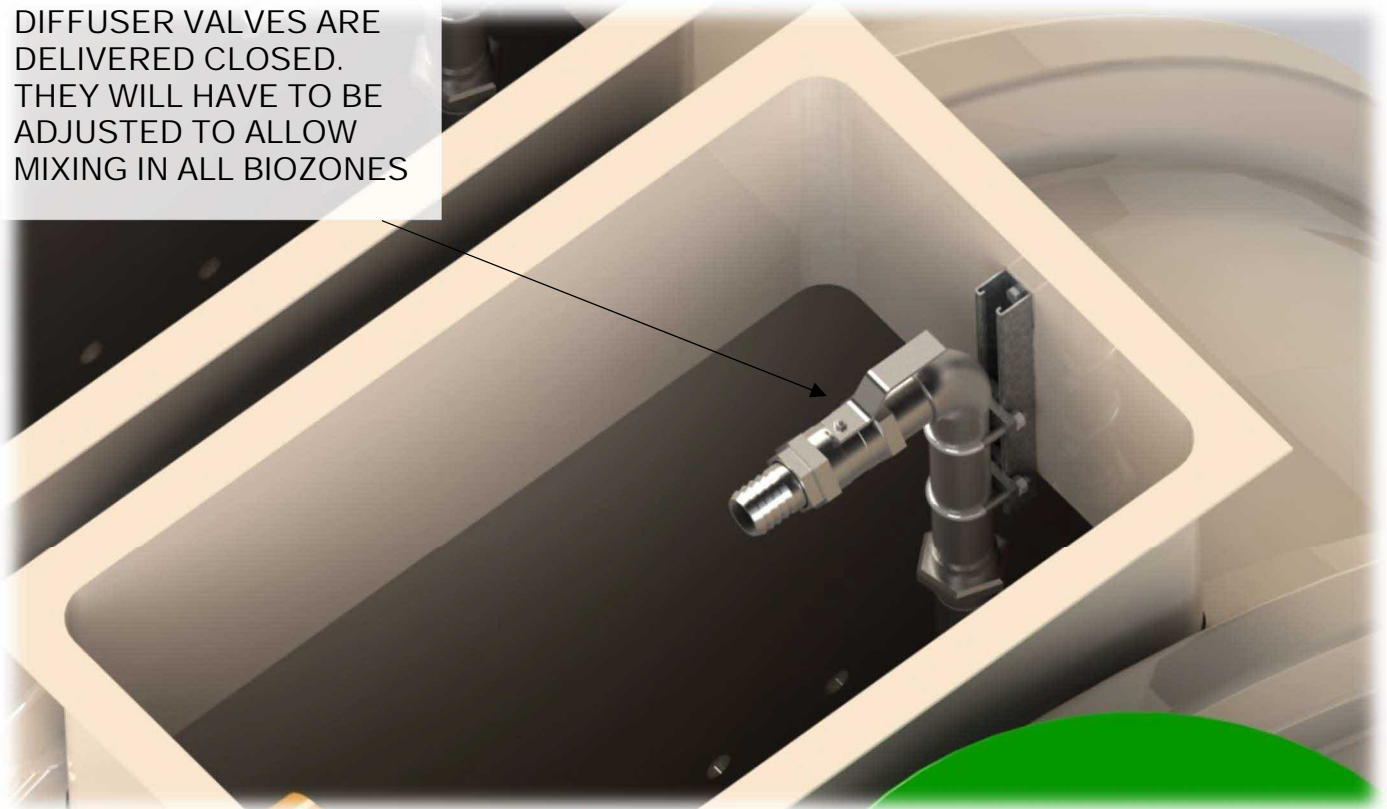

7. OPTIMISING PERFORMANCE

- Once the plant has seeded itself biologically there will be a visible growth on the media circulating around the biozones. This can be light or dark brown if the plant is operating normally.
- During biological start up there may be quite a lot of foam in the biozones. This usually subsides quite quickly as the population of bacteria on the media increases.
- The internal recirculation can be adjusted to modify the treatment operation, this changes the amount of nitrate returned as well as the dilution rate on the incoming sewage. In the absence of any analytical data we do not recommend making any changes to plant settings other than the forward flow air lifts.
- In general, the “slower” the plant the better the performance.
- Air blowers should not be restricted, either by operating with dirty inlet air filters or by closing the valves on the diffusers in the biozones.
- After a period of normal operation, the plant will require de-sludging/tankering. The Guidelines give the procedure and suggested interval for de-sludging. However, if the load on the plant is significantly different then the interval may be adjusted to suit. The procedure should always be the same.
- If the load is seasonal, then the de-sludging can also be adjusted to a seasonal cycle.
- If the biozones appearance changes from a dark to a more milky liquid, it is usually a sign that the plant is ready for de-sludging. It can also be a sign of excessive fat in the sewage, or a high proportion of detergent (laundry), or even an overload due to a change from the nature of the source and/or magnitude of the incoming sewage!

FORWARD FEED CONTROL VALVES (GREEN) ARE SUPPLIED CLOSED. THEY MUST BE ADJUSTED DURING PLANT COMMISSIONING TO ACHIEVE THE CORRECT FORWARD FLOW RATE. THIS CAN BE MEASURED AT THE OUTLET SAMPLE CHAMBER.

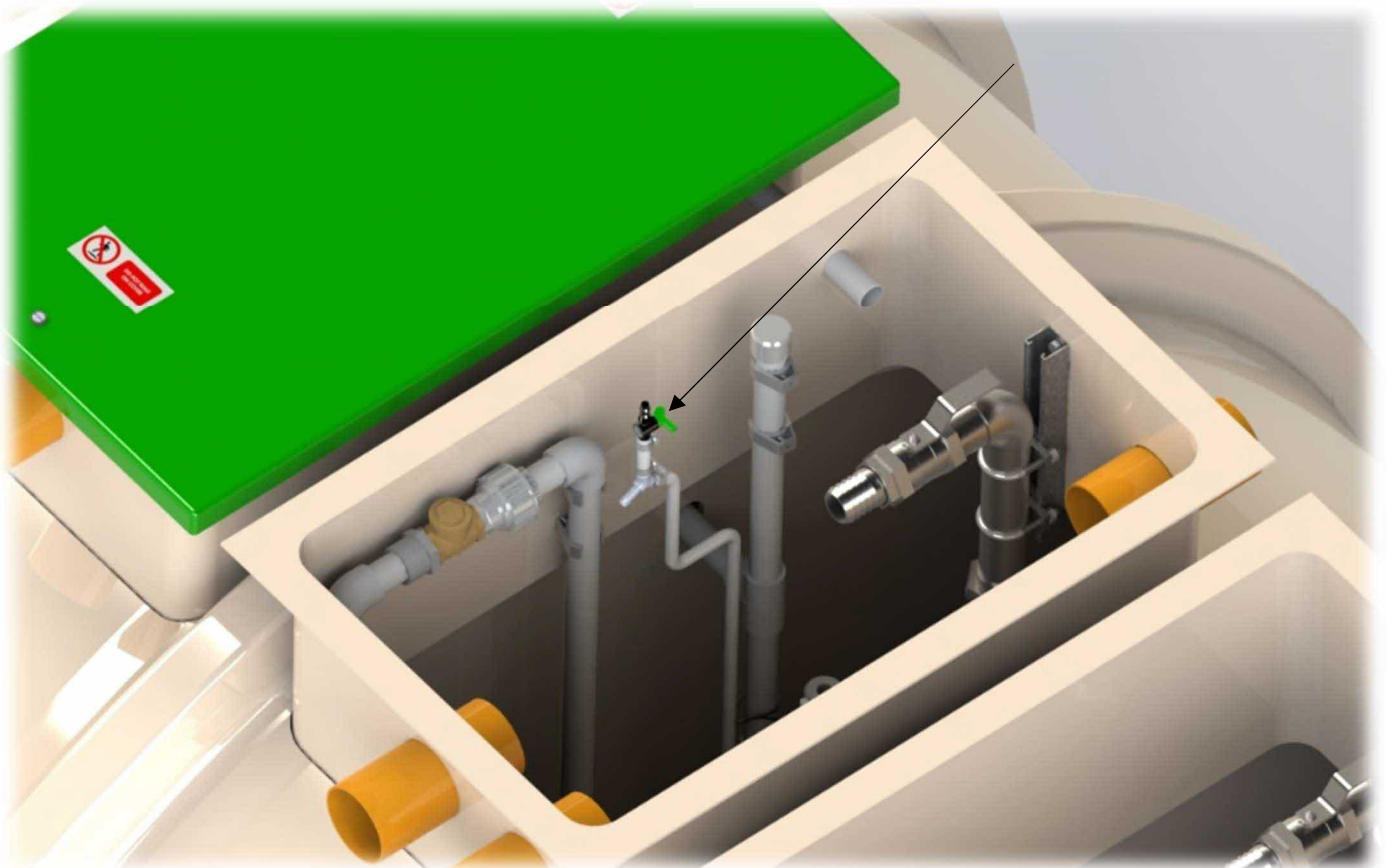

15. FAQ's.

20 Frequently asked questions; if you do not find your answer please contact our technical team.

1. <i>General</i>	<ul style="list-style-type: none"> Maintenance and service checks should be carried out by suitably trained personnel. Electrical equipment should only be worked on by suitably skilled personnel.
2. <i>Can I get into the tank to fix something?</i>	<ul style="list-style-type: none"> On no account should anybody enter the tank.
3. <i>Is it safe to work on the plant?</i>	<ul style="list-style-type: none"> If suitable safety precautions are observed. Always wear rubber/latex gloves. Safely isolate the electricity supply to the plant Always wash thoroughly after contact with the plant. Do not eat/drink or smoke without washing hands first. Any splashes into the eye should be rinsed with saline water SEEK MEDICAL ADVICE. If any liquid in the plant is swallowed, do not induce vomiting, drink plenty of water, seek medical attention.
4. <i>Something has fallen into the tank.</i>	<ul style="list-style-type: none"> Do not attempt to enter the tank. If the item floats, use a fishing net or similar tool to remove. If it sinks and it is magnetic, tie a strong magnet to a rope and attempt to remove it. In the majority of cases small items are not a problem, but check the diffusers for damage particularly if vigorous "boiling" is evident
5. <i>There is foam oozing out of the vent/access covers.</i>	<ul style="list-style-type: none"> This is normal on start up of this type of biological process. It will subside in a few days depending on the connected load on the plant. Water spray will knock it down or small doses of silicon based anti foam may be used.
6. <i>There is a dry crust on the surface of the primary tank.</i>	<ul style="list-style-type: none"> This is quite normal and will not cause any problems. When the tank is "de-sludged", this crust will be removed.
7. <i>There is a dark brown wet sludge on the surface of the final settlement zone.</i>	<ul style="list-style-type: none"> This is a good indication that the process is operating, but may also indicate a problem with the sludge return pump. Isolate the power to the plant, remove the pump and check operation.
8. <i>A noise like a vigorous boiling water is coming from one of the access points.</i>	<ul style="list-style-type: none"> The diffuser may have come off.
9. <i>The plant is smelling like raw sewage, slightly sickly sweet.</i>	<ul style="list-style-type: none"> Check that the air blower is operating, check the inlet air filter on the blower, if blocked fit a clean one. Check the liquid level in the plant, is there a blockage downstream causing the liquid to back up? (Particularly Soak-aways and drainage mounds). Check for indications of toxic chemicals such as disinfection, drain cleaning products or caustic based cleaners etc.

017610 Bioficient WWTP Installation & Maintenance Guideline

<p>10. There is a white growth in the water course where the plant discharge is.</p>	<ul style="list-style-type: none"> • A sign of poor treatment. The biological process is overloaded, the blower is under performing, Toxic chemicals, disinfectants, cleaners etc
<p>11. The water discharging from the plant has a rainbow sheen on it.</p>	<ul style="list-style-type: none"> • Petroleum products, oil or diesel have been discharge into the plant. Locate source and eliminate. • The plant will recover from small discharges but a large discharge may require a special tanker, contact your local licensed waste disposal company.
<p>12. The blower discharge pipe is very hot.</p>	<ul style="list-style-type: none"> • If the blower is too hot, check the air filter, if there is a large resistance to removing the cover, the filter is blocked, replace. • Check that the valves on the aeration drop pipes are open. • Check the water level in the tank: high level the blower works harder so temperature high. • The blower will normally be 25°C to 30°C higher than the outside air temperature. • Are the ventilation louvers in kiosk clear, run with the kiosk door open for 10-15 minutes, does the blower cool down? If yes, increase the ventilation into the kiosk. • Are there any signs of the blower pipe work being damaged or crushed?
<p>13. The final effluent is cloudy.</p>	<ul style="list-style-type: none"> • This usually occurs when the plant de-sludge is overdue. • Check service records and arrange de-sludge. • Other causes are “process” related and normal checks should be made on the blower, toxic chemicals and un-authorized discharges.
<p>14. The final effluent is coloured.</p>	<ul style="list-style-type: none"> • This can be: unauthorised discharges, or ground water entering the plant
<p>15. Total nitrogen in the final effluent is high (H range plants only)</p>	<ul style="list-style-type: none"> • Isolate the power to the plant; remove the recycle pump and check. • Contact your service provider for advice.
<p>16. Total phosphorous in the final effluent is high. (H range with Chemical dosing only)</p>	<ul style="list-style-type: none"> • Check the chemical levels. • Check the chemical dosing pump is delivering (Wear necessary PPE). • Check the pipe work for damage/blockage. • Check chemical dosing increments (do they need increasing?).
<p>17. What position should the ball valves in the diffuser pipes be?</p>	<ul style="list-style-type: none"> • Valve position is determined by airflow so all plants may vary. • Position valves so media is agitated but not moving violently.
<p>18. Will the air diffusers need cleaning.</p>	<ul style="list-style-type: none"> • Not in normal operation. • Flow of air will unblock diffusers.
<p>19. My warning beacon is flashing.</p>	<ul style="list-style-type: none"> • Check control panel for fault (see next page).

16. Control Panel Fault Messages

The control panel will operate a fault message in the following situations:

<p>SYSTEM ON NO FAULTS</p>	<p>When the system is on and there are no faults then this message appears to show that the system is running without any problems.</p>
<p>MULTIPLE ALARMS</p>	<p>This message will appear when there is more than one fault with the system.</p>
<p>RECIRCULATION PUMP FAULT</p>	<p>This message will appear when there is a fault with the recirculation pump 1 located in Biozone 3.</p>
<p>DESLUDGE PUMP FAULT</p>	<p>This message will appear when there is a fault with the recirculation pump 2 located in the FST.</p>
<p>BLOWER No.1 PRESSURE FAIL</p>	<p>This message will appear when there is a loss of pressure in the large blower for the diffusers. This indicates that the blower is not operating, or that there is a pipe rupture. You should investigate these situations, rectify, the alarm will clear.</p>
<p>BLOWER No.2 PRESSURE FAIL</p>	<p>This message will appear when there is a loss of pressure in the large blower for the diffusers. This indicates that the blower is not operating, or that there is a pipe rupture. You should investigate these situations, rectify, the alarm will clear.</p>

<p style="text-align: center;">BLOWER No.3 PRESSURE FAIL</p>	<p>This message will appear when there is a loss of pressure in the large blower for the diffusers. This indicates that the blower is not operating, or that there is a pipe rupture. You should investigate these situations, rectify, the alarm will clear.</p>
<p style="text-align: center;">BLOWER No.4 PRESSURE FAIL</p>	<p>This message will appear when there is a loss of pressure in the small blower for the airlift. This indicates that the blower is not operating, or that there is a pipe rupture. You should investigate these situations, rectify, the alarm will clear.</p>
<p style="text-align: center;">HIGH LEVEL ALARM</p>	<p>This message will appear when the water level has got higher than the working level which in turn triggers the high level float in the Biozone 2. You should investigate the cause, by checking within the compartment, rectify the problem (probable cause, air lift non-operational). Once the cause has been rectified and the level has dropped the alarm will clear.</p>
<p style="text-align: center;">BLOWER MOTOR No.1 FAULT</p>	<p>This message will appear when there is a fault with the large blower for the diffusers and it's stopped working.</p>
<p style="text-align: center;">BLOWER MOTOR No.2 FAULT</p>	<p>This message will appear when there is a fault with the large blower for the diffusers and it's stopped working.</p>
<p style="text-align: center;">BLOWER MOTOR No.3 FAULT</p>	<p>This message will appear when there is a fault with the large blower for the diffusers and it's stopped working.</p>
<p style="text-align: center;">BLOWER MOTOR No.4 FAULT</p>	<p>This message will appear when there is a fault with the small blower for the airlift and it's stopped working.</p>

17. Notice to affix within the building



Bioficient

The foul drainage from this property discharges into a package treatment works.

Maintenance is required, the frequency of which depends upon the model installed, its use and application. Please consult your Operation & Maintenance Manual.

- * When operating at the normal daily load, emptying should take place at 90 day intervals.
- * The frequency of sludge removal is expected to increase if the unit is chemically dosed and require more frequent maintenance (see individual operating manuals)

Maintenance and Desludging should be carried out by the owner in accordance with the Manufactures instructions.

THE OWNER OF THE PROPERTY IS LEGALLY RESPONSIBLE FOR ENSURING THAT THE SYSTEM DOES NOT CAUSE POLLUTION, A HEALTH HAZARD OR A NUISANCE.

We recommend that a separate log is kept of all maintenance and service visits, the log should detail the date and any action taken, e.g. Regular maintenance service, breakdown visit, desludge volume removed, parts replaced.

This notice should be fixed by the owner within the building alerting current and future owners to the maintenance requirement.

(Building regulation H2 (1.57))

Please contact Service or [REDACTED] to arrange a maintenance service or to request replacement operating instructions. It would be helpful if you provide your equipment serial number.