

Elevations - 1:20

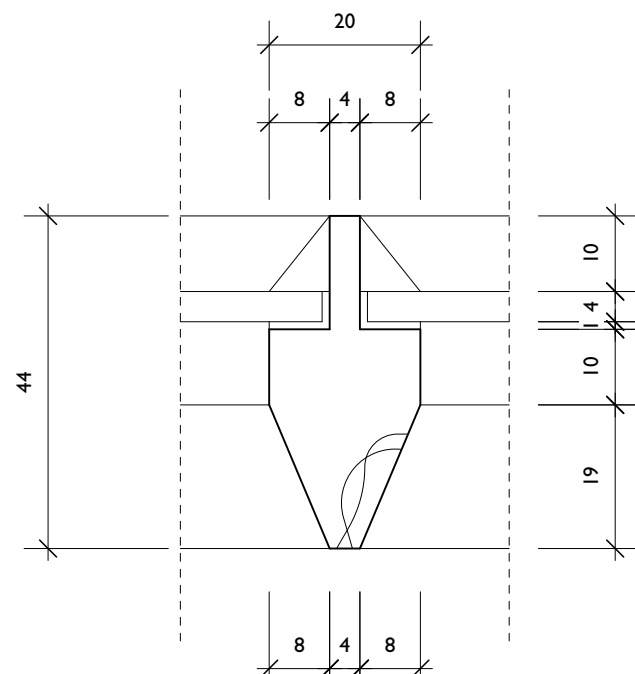

44mm Glazing Bar 1:1

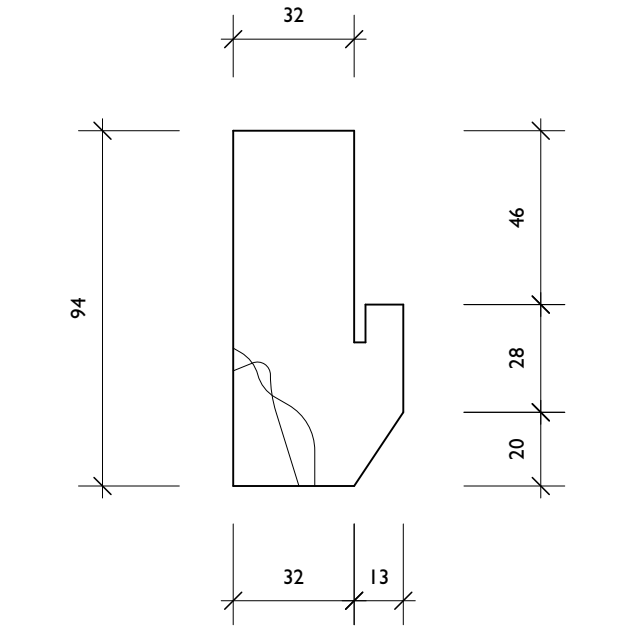

Jamb Detail - 1:2

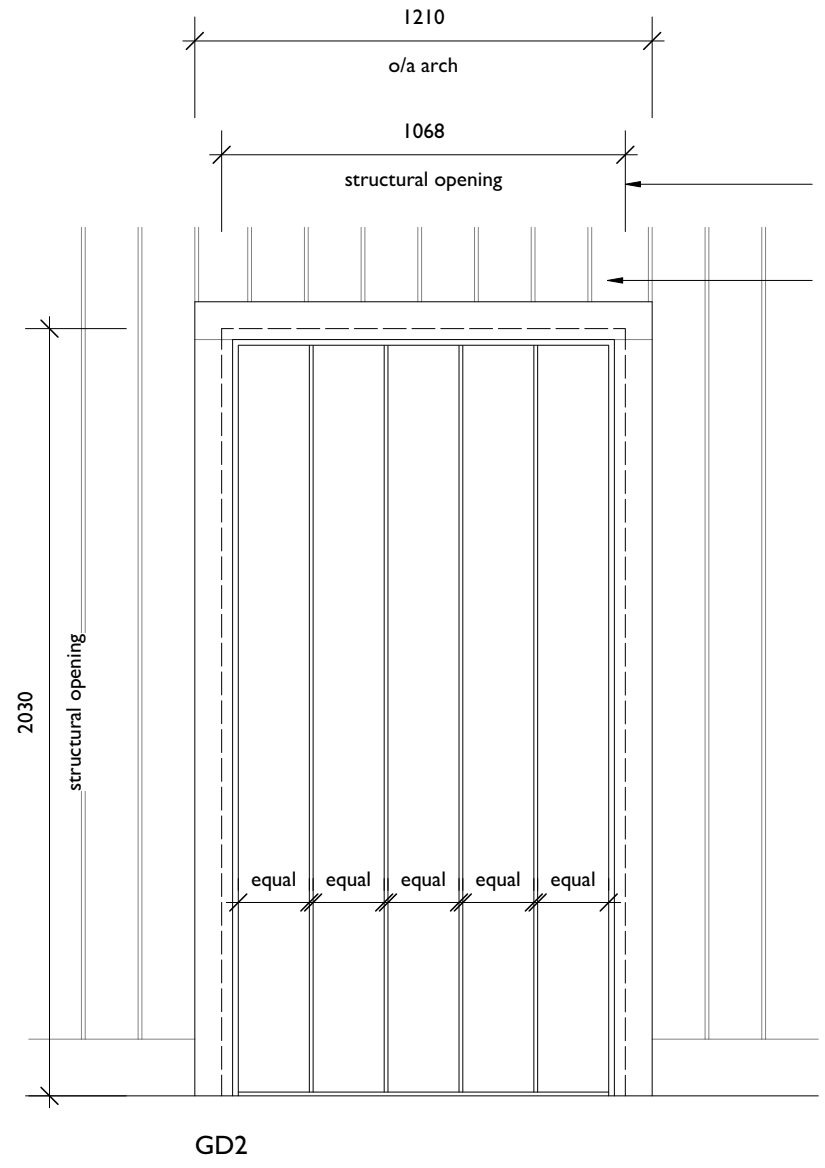

GD2

* door structural opening to timber frame. Plywood lining inside of this opening

Careful setting out of vertical beaded boarding as shown. Bead terminated into top of architrave.

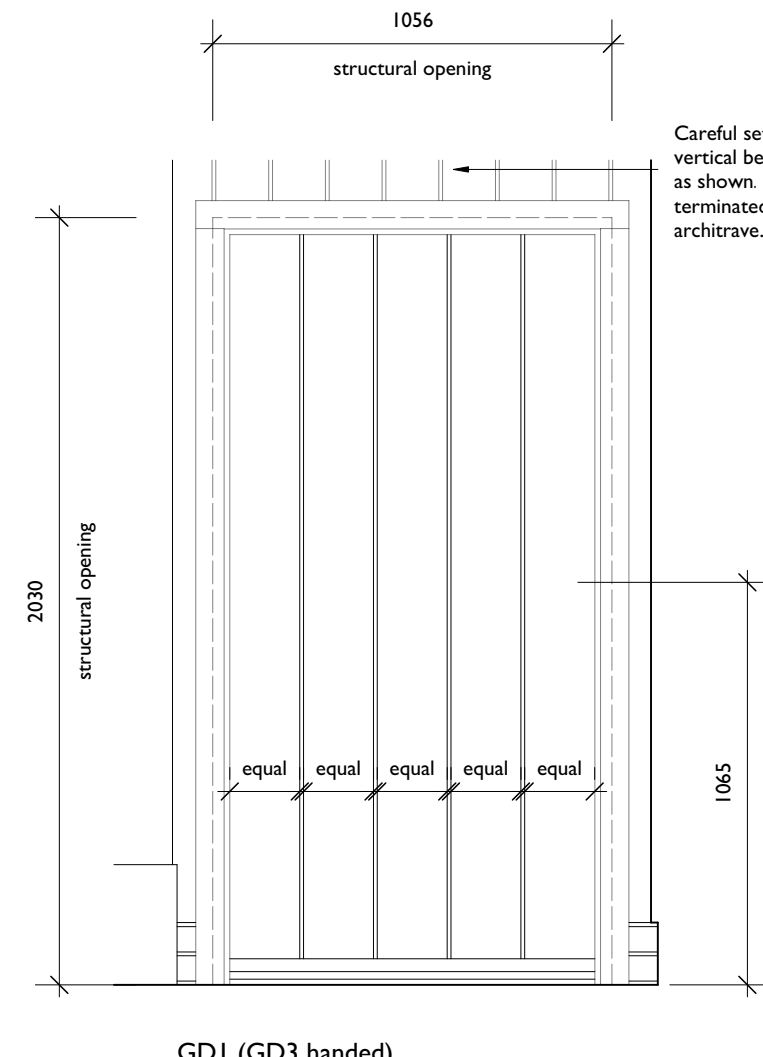
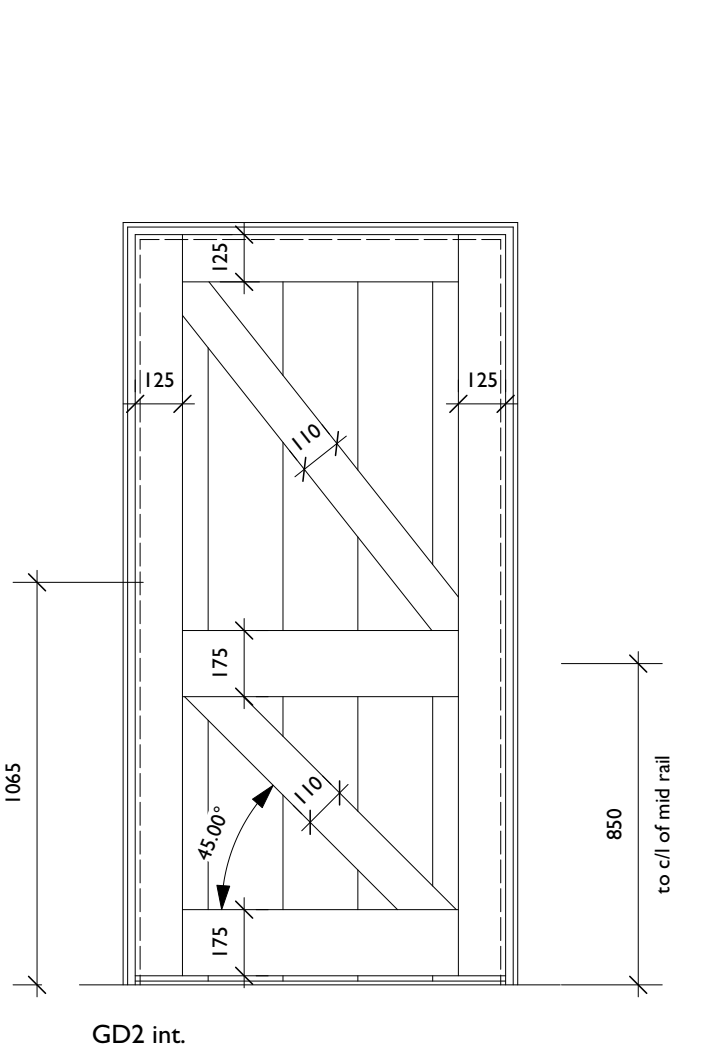

GD1 (GD3 handed)

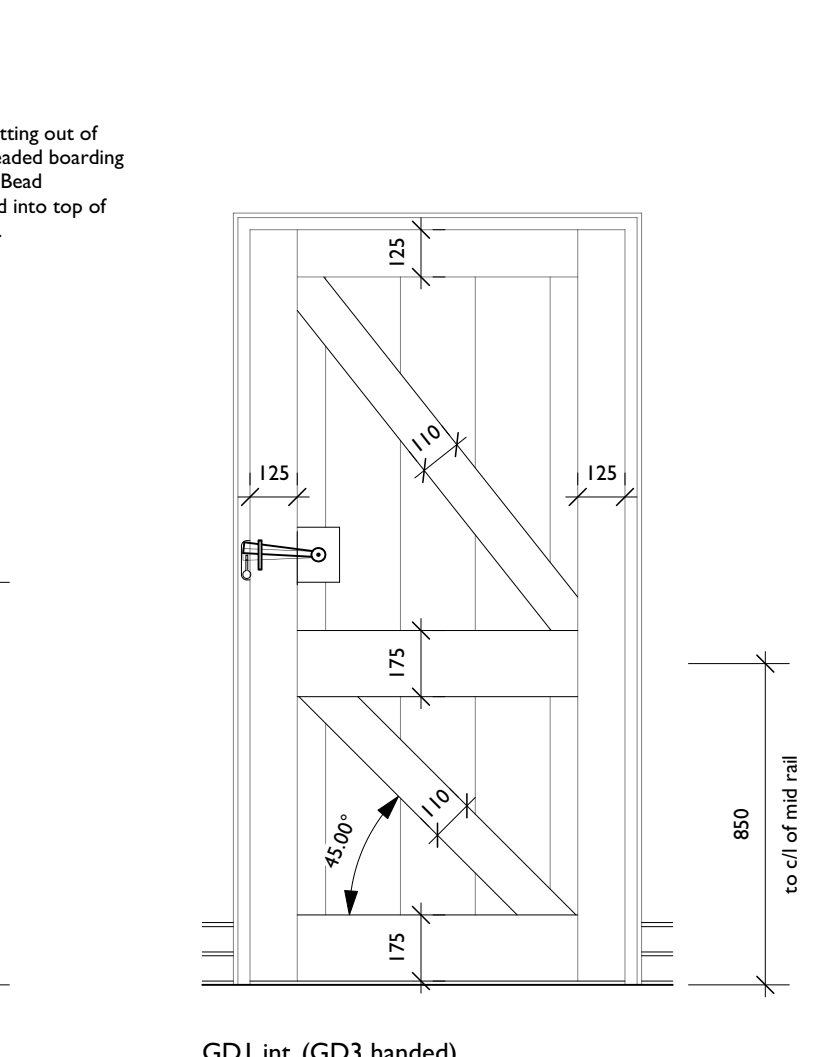

GD1 int. (GD3 handed)

Vertical Section Through Single Glazed Store Window - 1:5

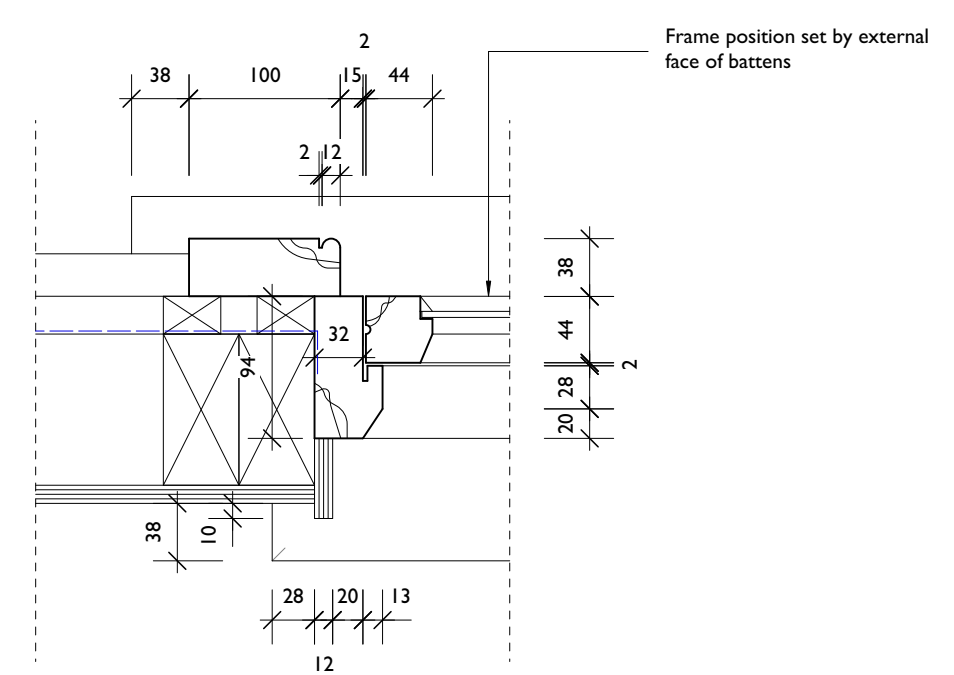

Horizontal Section Through Single Glazed Store Window - 1:5

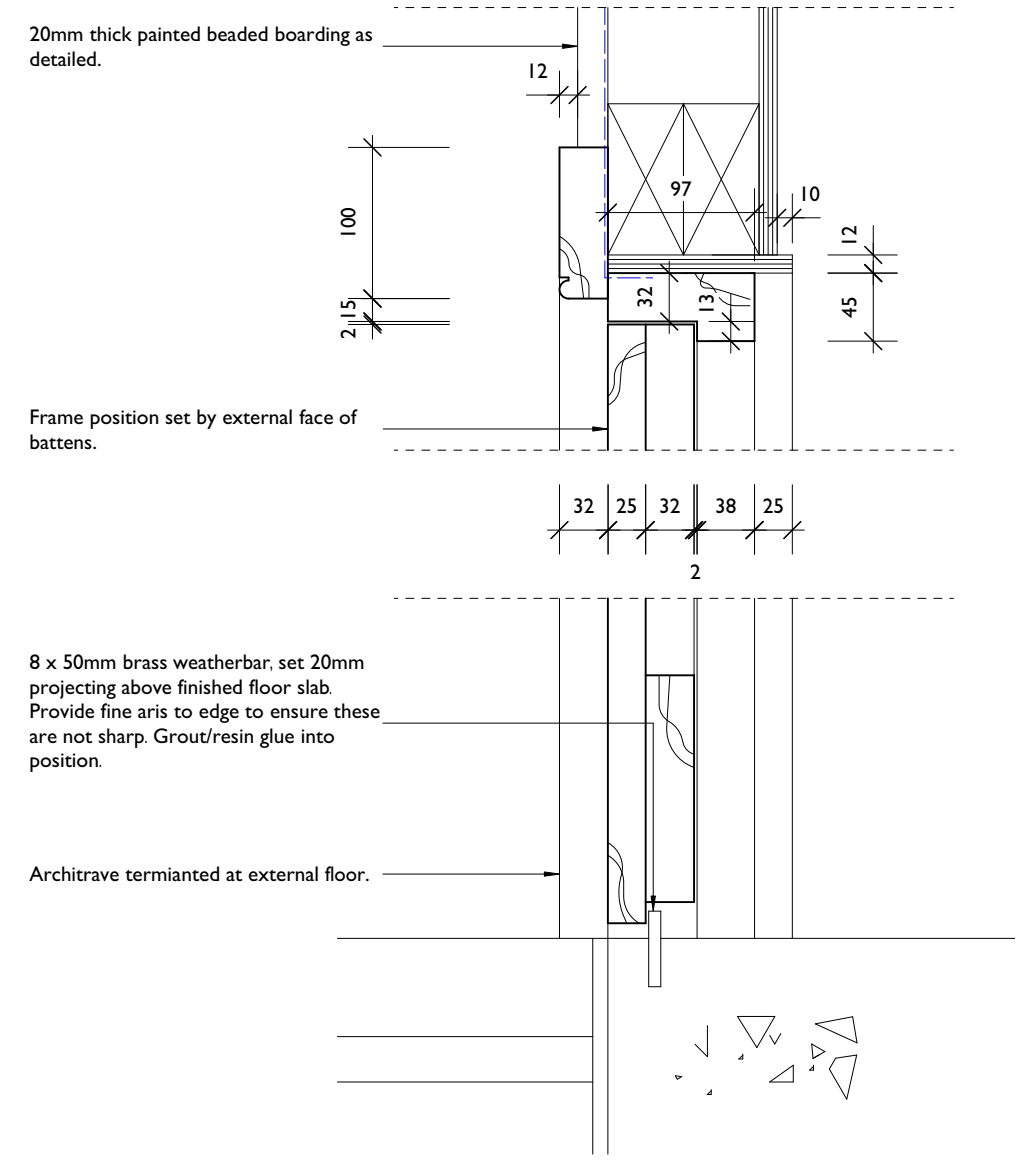
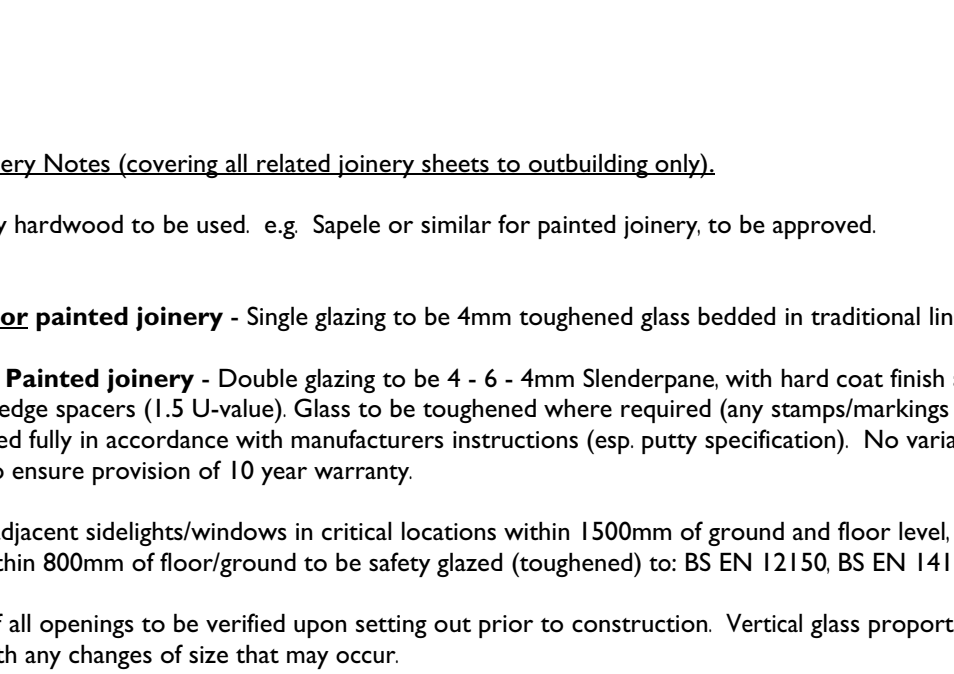

Vertical Section Through GD2 - 1:5

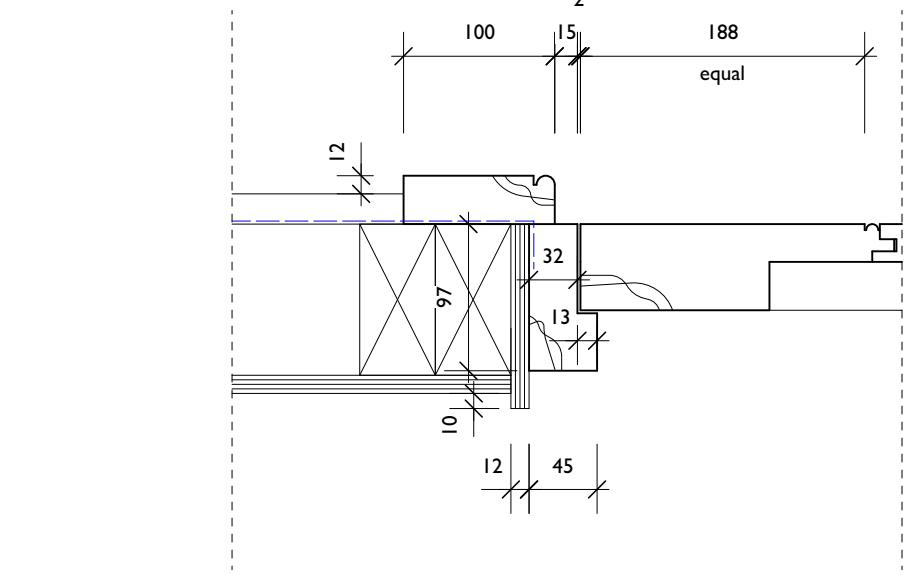

Horizontal Section Through GD2 - 1:5

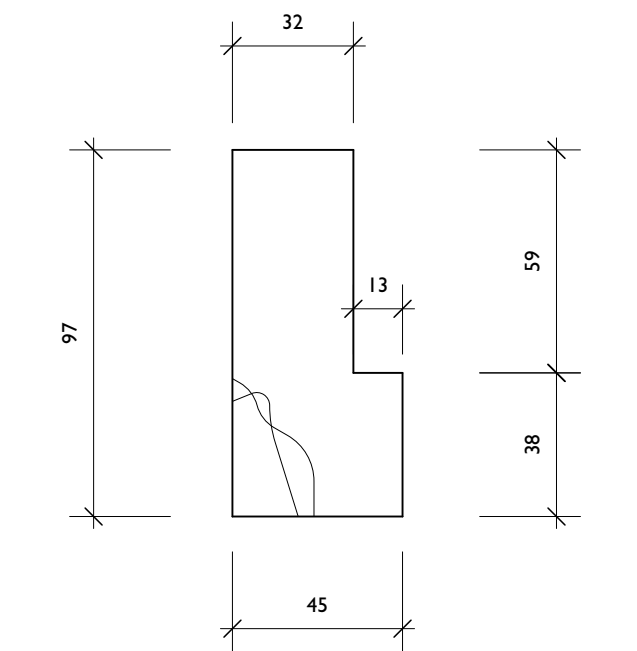

Door Jamb Detail - 1:2

General Joinery Notes (covering all related joinery sheets to outbuilding only).

Good quality hardwood to be used. e.g. Sapele or similar for painted joinery, to be approved.

Ground floor painted joinery - Single glazing to be 4mm toughened glass bedded in traditional linseed based putty.

First Floor Painted joinery - Double glazing to be 4 - 6 - 4mm Slenderpane, with hard coat finish and with krypton filled cavity, black warm edge spacers (1.5 U-value). Glass to be toughened where required (any stamps/markings to be approved by Designer). To be installed fully in accordance with manufacturers instructions (esp. putty specification). No variance from specification permitted to ensure provision of 10 year warranty.

Doors and adjacent sidelights/windows in critical locations within 1500mm of ground and floor level, and 300mm of doors and windows within 800mm of floor/ground to be safety glazed (toughened) to: BS EN 12150, BS EN 14179 and BS EN 14449

Final sizes of all openings to be verified upon setting out prior to construction. Vertical glass proportions to be maintained, consult Designer with any changes of size that may occur.

Allow for Aquamac weatherseals or similar approved, grooves shown on joinery are indicative. Capillary grooves to be incorporated, any shown are indicative. Any additional details and samples to be agreed with Designer. At rebated openings take special care to ensure continuity of weatherseal.

NO WEATHERSEALS TO EXTERNAL DOORS TO OUTBUILDING.

Complete and full architraves to be used in all instances. Consult Designer at earliest opportunity if full architrave can not be accommodated.

Where architraves terminate on a cill/threshold, horns to cill/threshold to be 38mm past outer edge of architrave unless otherwise stated.

Ironmongery recesses to be machined off site as required. Contractor to agree ironmongery with client prior to joinery fabrication.

All external doors to have laminated stiles, lower, mid and top rails.

Specification and storage considered with steps taken to minimise shrinkage and movement. Grain alignment to be considered to minimise the effect of shrinkage and movement.

Joinery to be decorated off site, excluding top finishing coat with proprietary primer and basecoats. No spray finishes (except primer).

Should joinery be stored on site prior to fixing, this to be done to minimise damage and deformation of timber.

Tops and bottoms of doors to receive painted finish. Ironmongery to remain spot free upon completion. Slotted screws to all visible fixings.

Timber thresholds below painted doors to be unpainted and have Osmo clear UV-protection oiled finish.

All timber to be UKWAS or FSC certified.

Paint colours of all joinery to separate details, or to clients specification, as appropriate.

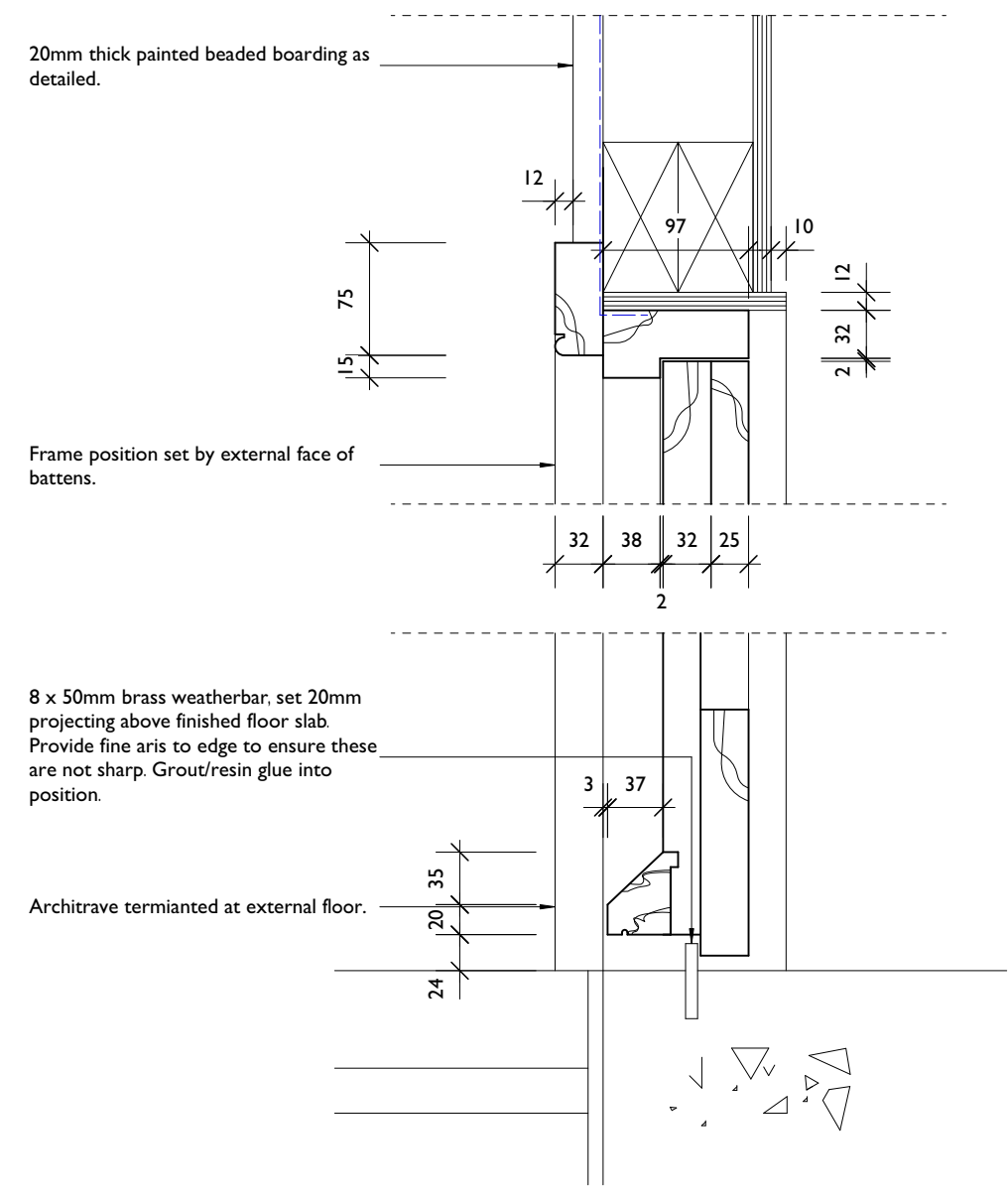

Vertical Section Through GD1 & GD3 - 1:5

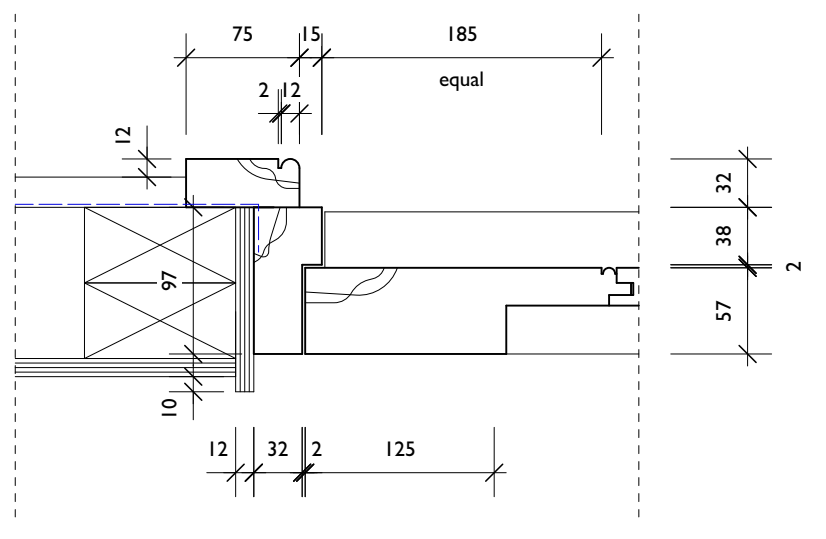

Horizontal Section Through GD1 & GD3 - 1:5

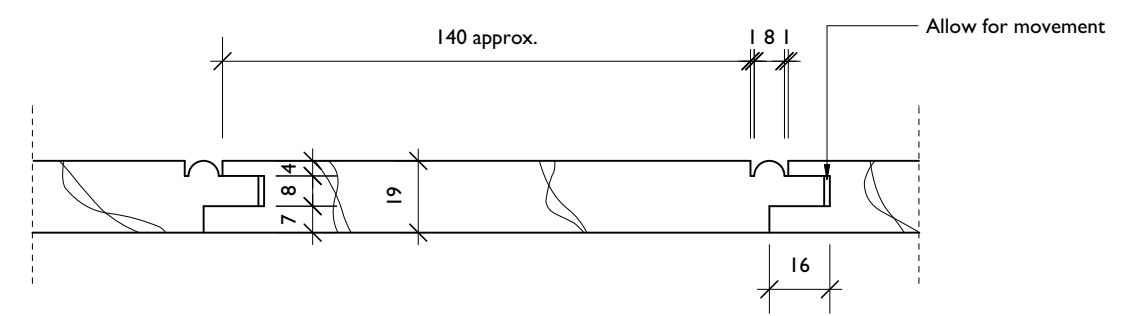

Typical Painted Boarding Detail For Covered Area - 1:2

(Bead profile to be used on boarded doors)

DRAFT

This drawing to be read strictly in accordance with the General Notes and Residual Risk to Health and Safety Information on drawing no. 1121-11

ROGER BALMER
DESIGN

FOUNTAIN HOUSE STUDIO THE STREET EAST BERGHOLT COLCHESTER CO7 6TB
Telephone: 01206 299477 Email: enquiries@rogerbalmerdesign.co.uk

Client	Project	Drawing
Mr and Mrs Duckworth-Chad	Sparrows Shelley Suffolk	Outbuilding Joinery Details Sheet 1
Scale	Date	Del.
As noted at A1	July 2022	BOC
		Drawing no. Rev.
		1121 - 13

Contractors must verify all dimensions and information on site prior to commencement of work. Do not scale from drawing.
© Roger A Balmer Ltd