

NOTES  
 Do not scale from this drawing. Only figured dimensions are to be taken from this drawing.  
 Contractor must verify all dimensions on site before commencing any work or shop drawings.  
 Report any discrepancies to the architect before commencing work. If this drawing exceeds the quantities taken in any way the architects are to be informed before the work is initiated.  
 Work within the Construction (Design & Management) Regulations 2015 is not to start until Pre Construction Health and Safety Information has been produced by the Principal Designer and a Principal Contractor has produced a Construction Phase Health and Safety Plan.  
 This drawing is copyright and must not be reproduced without consent of BSB Architecture  
 This drawing originates from the CAD file:  
 S:\2021\21825\_Lime Tree Avenue, York\010\_BSB Drawings\020\_Current Issue\025\_Appraisal\21825\_BSB\_00\_XX\_M2\_A\_0003\_0004 Existing And Proposed Elevations.dwg

**REVISIONS**

Rev	Description	Own	Date	Chk	Date

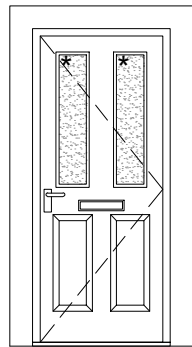

PROPOSED COMMUNAL EXTERNAL DOOR

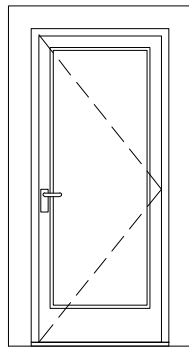

PROPOSED REAR / BALCONY EXTERNAL DOOR

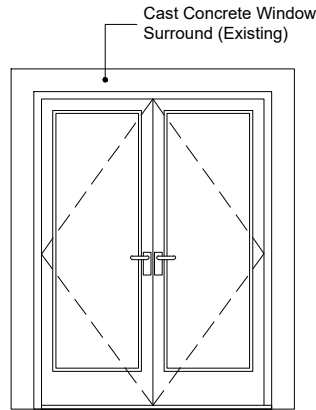

Cast Concrete Window Surround (Existing)

**PROPOSED EXTERNAL DOOR ELEVATIONS**  
 Scale 1:50

\* OBSCURE GLAZING - COTSWOLD PATTERN  
 REPLACEMENT DOOR FOR DOORS WITH OBSCURE GLAZING TO ALSO BE FITTED WITH OBSCURE GLAZING

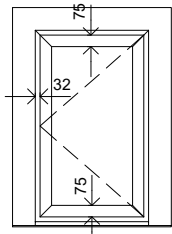

TYPICAL SMALL WINDOW

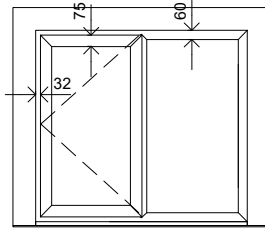

TYPICAL WINDOW

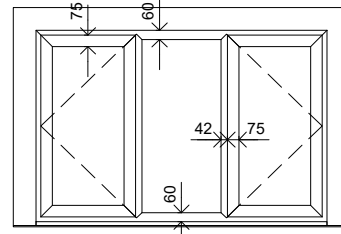

TYPICAL 3 PANE WINDOW

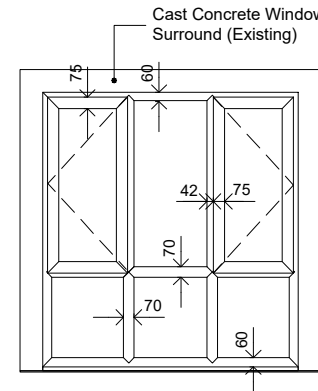

TYPICAL TALL WINDOW & LOWER PANEL WINDOW

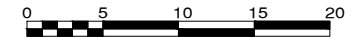

**BSB Architecture**

The Deep Business Centre  
 Tower Street  
 Kingston upon Hull - HU1 4BG  
 Tel : 01482 329 276  
 Fax: 01482 213 602  
 Email: info.bsbarchitecture@gmail.com

**RIBA**



CLIENT  
**Joseph Rowntree Housing Trust**

PROJECT  
**New External Doors & Windows**  
 Lime Tree Avenue,  
 New Earswick YO32 4BE

DRAWING TITLE  
**Typical Door & Window Elevations**

**TYPICAL PROPOSED WINDOWS**  
 Scale 1:50

REPLACEMENT WINDOWS FOR WINDOWS WITH OBSCURE GLAZING TO ALSO BE FITTED WITH OBSCURE GLAZING - COTSWOLD PATTERN

Drawing Status For Information_S2	Scale 1:50	Sheet Size A4
 	Drawn pm	Date 15/07/22
	Checked jnh	Date 15/07/22
Drawing No. 21825-BSB-00-XX-DR-A-0005	Revision /	