

Claire Jones

Subject: FW: Q1196 - Application for Removal of Condition (20/1833/FUL)
Attachments: Non-Material Amendment Application (Page 1 - inc App Name and Postal Address).pdf; Non-Material Amendment Application.pdf

From: Michael Rowland <Michael.Rowland@knightsconstruction.co.uk>
Sent: 22 July 2022 08:38
To: Planning Services <planning.services@powys.gov.uk>
Cc: Lewis Taylor <Lewis@knightsconstruction.co.uk>; Simon Madigan <Simon.Madigan@knightsconstruction.co.uk>
Subject: Q1196 - Application for Removal of Condition (20/1833/FUL)
Importance: High

Good morning,

Please see attached the application for removal of condition 7 of the above planning application (20/1833/FUL).

Condition 7 of the planning application requires the installation of a passing place along U2577. As per Manual for the Streets Figures 6.18 and 7.1, as shown below, the minimum width requirement is 5.5m. As per the attached drawing "Access Road Survey", following a survey of the location by our engineer the maximum achievable width achievable is 4.789m with the current hedge line, whilst the customer does not own the land behind the hedge.

Please also note this is a low volume road as there is only 1nr dwelling and the clients farm utilising the road as access.

Due to the above we are requesting that Condition 7 of the application 20/1833/FUL is removed.

Should you have any further queries please don't hesitate to get in touch.

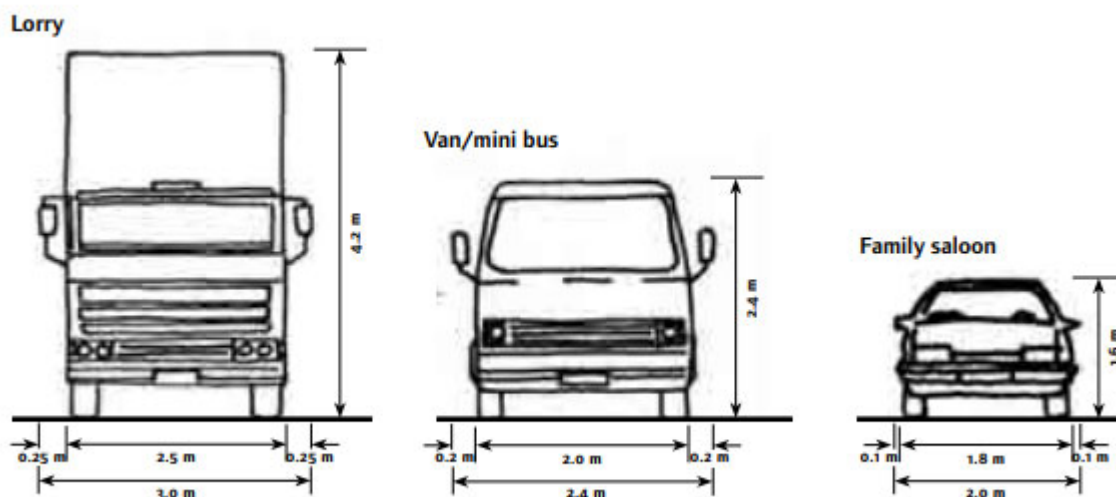

Figure 6.18 Private and commercial motor-vehicles – typical dimensions.

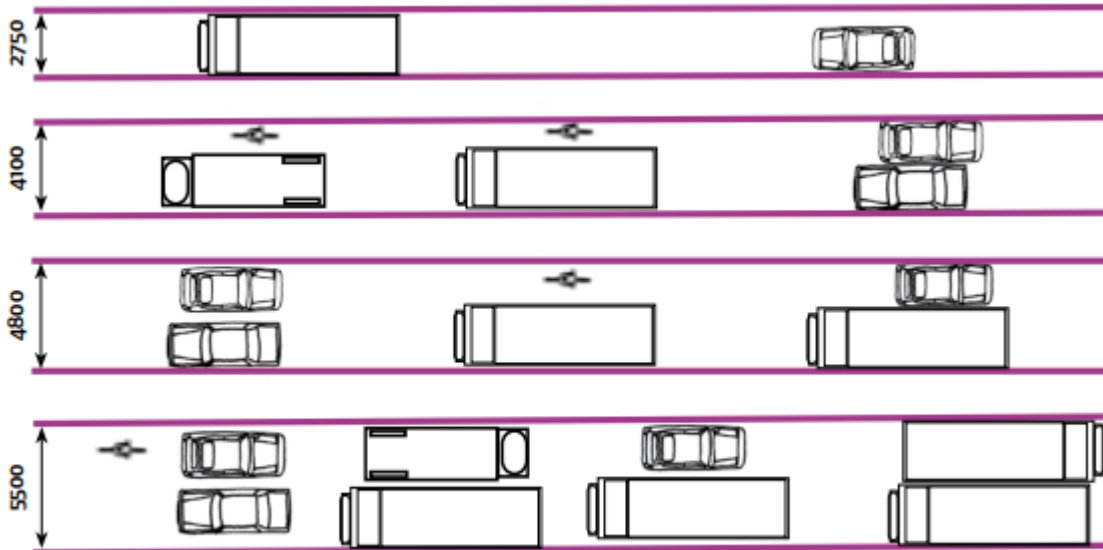

Figure 7.1 Illustrates what various carriageway widths can accommodate. They are not necessarily recommendations.

Regards

Mike Rowland
Assistant Quantity Surveyor

t: 01978 846 841 – Ext 214

e: Michael.Rowland@knightsconstruction.co.uk

w: www.knightsconstructiongroup.co.uk

a: Hafod y Bwch, Middle Sontley, Wrexham, LL13 0YP



Knights Construction Limited is a limited company registered in England and Wales. Registered number:7032967. Registered office:Hafod Y Bwch Farm, Middle Sontley, Wrexham, LL13 0YP Please note that Knights Construction Limited may monitor email traffic data and also the content of email for the purposes of security and staff training. This message (and any associated files) is intended only for the use of the intended recipient and may contain information that is confidential, subject to copyright or constitutes a trade secret. If you are not the intended recipient you are hereby notified that any dissemination, copying or distribution of this message, or files associated with this message, is strictly prohibited. If you have received this message in error, please notify us immediately by replying to the message and deleting it from your computer. Any views or opinions presented are solely those of the author and do not necessarily represent those of the company.

Mae'r e bost hwn ac unrhyw atodiad iddo yn gyfrinachol ac fe'i bwriedir ar gyfer y sawl a enwir arno yn unig. Gall gynnwys gwybodaeth freintiedig. Os yw wedi eich cyrraedd trwy gamgymeriad ni ellwch ei gopio, ei ddsbarthu na'i ddangos i unrhyw un arall a dylech gysylltu gyda Cyngor Sir Powys ar unwaith. Mae unrhyw gynnwys nad yw'n ymwneud gyda busnes swyddogol Cyngor Sir Powys yn bersonol i'r awdur ac nid yw'n awdurdodedig gan y Cyngor.

This e mail and any attachments are confidential and intended for the named recipient only. The content may contain privileged information. If it has reached you by mistake, you should not copy, distribute or show the content to anyone but should contact Powys County Council at once. Any content that is not pertinent to Powys County Council business is personal to the author, and is not necessarily the view of the Council.

Mae'r e bost hwn ac unrhyw atodiad iddo yn gyfrinachol ac fe'i bwriedir ar gyfer y sawl a enwir arno yn unig. Gall gynnwys gwybodaeth freintiedig. Os yw wedi eich cyrraedd trwy gamgymeriad ni ellwch ei gopio, ei ddosbarthu na'i ddangos i unrhyw un arall a dylech gysylltu gyda Cyngor Sir Powys ar unwaith. Mae unrhyw gynnwys nad yw'n ymwneud gyda busnes swyddogol Cyngor Sir Powys yn bersonol i'r awdur ac nid yw'n awdurdodedig gan y Cyngor.

This e mail and any attachments are confidential and intended for the named recipient only. The content may contain privileged information. If it has reached you by mistake, you should not copy, distribute or show the content to anyone but should contact Powys County Council at once. Any content that is not pertinent to Powys County Council business is personal to the author, and is not necessarily the view of the Council.
