



1 Existing Window Elevation  
1:25@A3 ; 1:50@A4

2 Existing Window Side Elevation  
1:25@A3 ; 1:50@A4



EXISTING W01 ON SECOND FLOOR



EXISTING W01 ON SECOND FLOOR

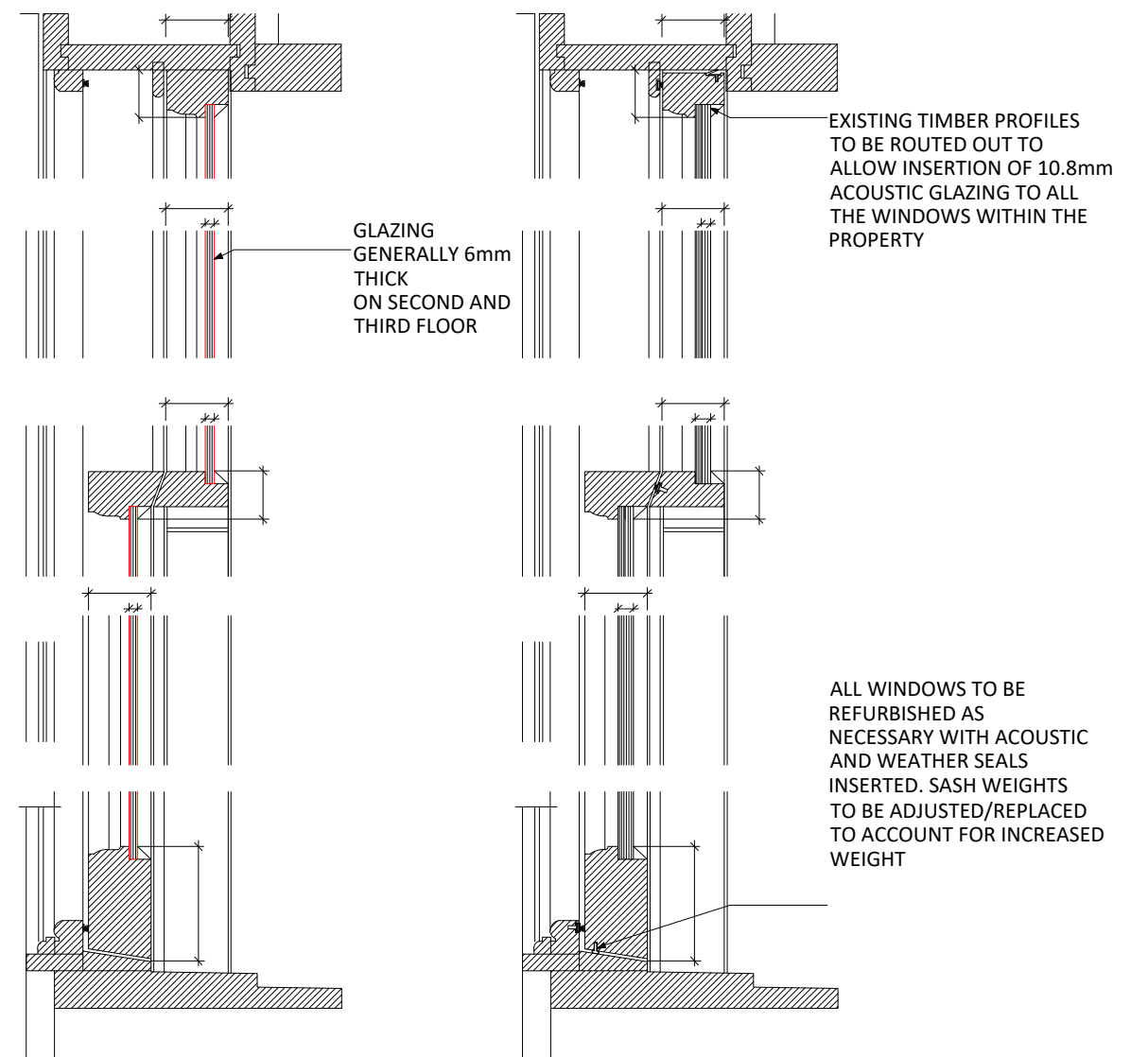

4 Existing Window-Section Detail  
1:5@A3 ; 1:10@A4

5 Proposed Window-Section Detail  
1:5@A3 ; 1:10@A4

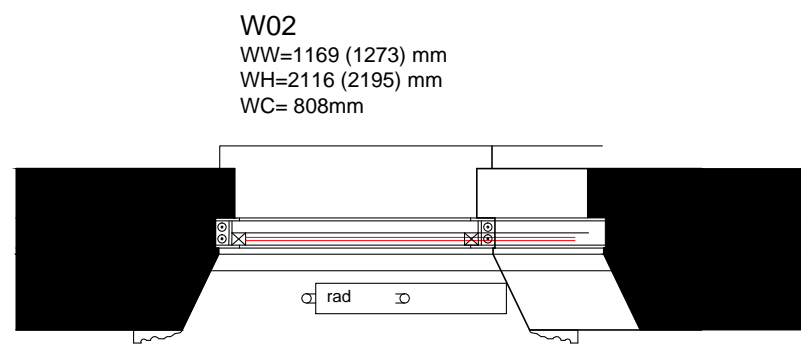

3 Existing Window Plan  
1:25@A3 ; 1:50@A4

EXISTING WINDOWS SUBJECT TO REFURBISHMENT:  
SECOND FLOOR: W01, W02, W03  
THIRD FLOOR: W11, W13, W14, W15

NOTES  
SCALING FOR PLANNING PURPOSES ONLY.  
ALL DIMENSIONS TO BE CHECKED ON SITE.  
WORK TO BE CARRIED OUT IN ACCORDANCE WITH BYE-LAWS AND REGULATIONS OF LOCAL AUTHORITIES AND STATUTORY UNDERTAKERS.  
THIS DRAWING MAY INCORPORATE INFORMATION FROM OTHER PROFESSIONALS. KTB CANNOT ACCEPT RESPONSIBILITY FOR THE INTEGRITY AND ACCURACY OF SUCH INFORMATION. DRAWINGS, SPECIFICATIONS AND SCHEDULES ARE TO BE READ IN CONJUNCTION WITH ALL RELEVANT ARCHITECTS AND CONSULTANTS DRAWINGS AND SPECIFICATIONS.  
PRINT PDF OF THE DWG IN ACTUAL SIZE.

REV	NOTES	DATE	BY
A	ISSUED FOR PLANNING	19.07.2022	DA

STATUS PLANNING	
PROJECT 42 Lancaster Gate Flat E	
TITLE Proposed new acoustic glazing Windows Details	KTB architecture 15 Theod Street London SE1 8ST t +44 (0)20 7207 4903 w ktbarchitecture.com e hello@ktbarchitecture.com
SCALE AT A3: Varies	DWG NUM LST_110 REV A