

- Key**
- 1 Existing Stone Wall
 - 2 Existing Timber effect Rainscreen Cladding
 - 3 Existing French Doors
 - 4 Proposed Solar Canopy (See Figure 2)

- NOTES:**
1. If this drawing has been received electronically it is the recipients responsibility to print the document to the correct scale.
 2. All dimensions are in millimetres unless stated otherwise. It is recommended that information is not scaled off this drawing.
 3. This drawing should be read in conjunction with all other relevant drawings and specifications.

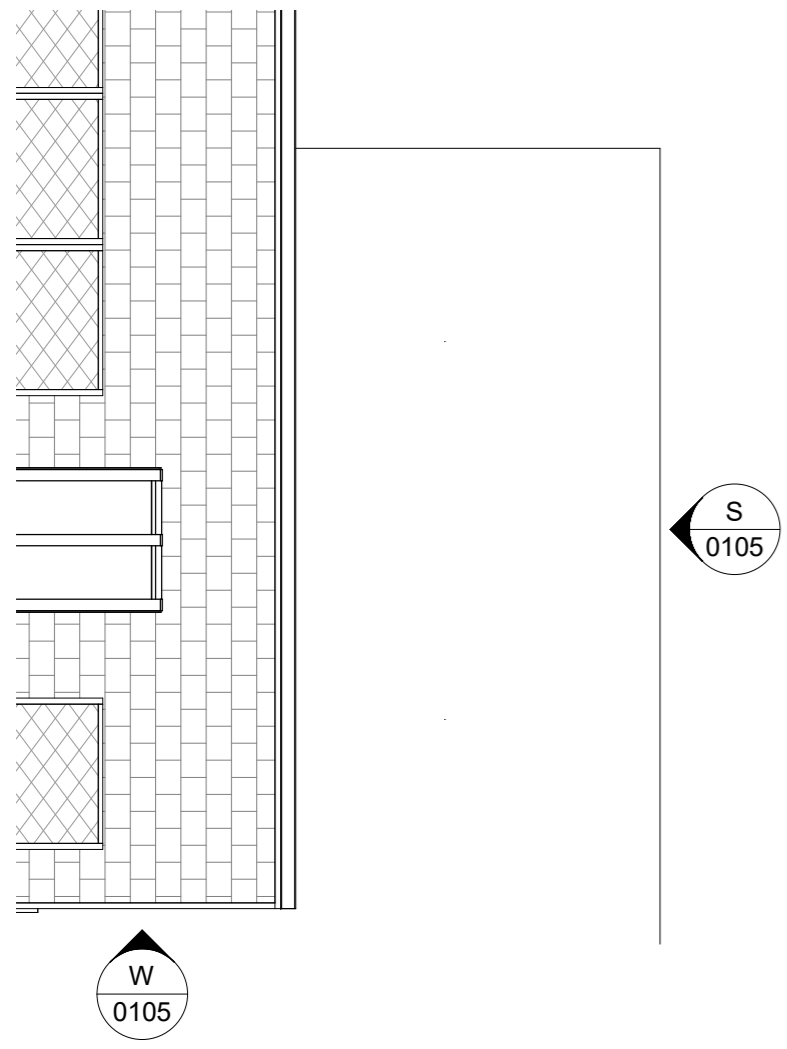

Existing Plan
1 : 50

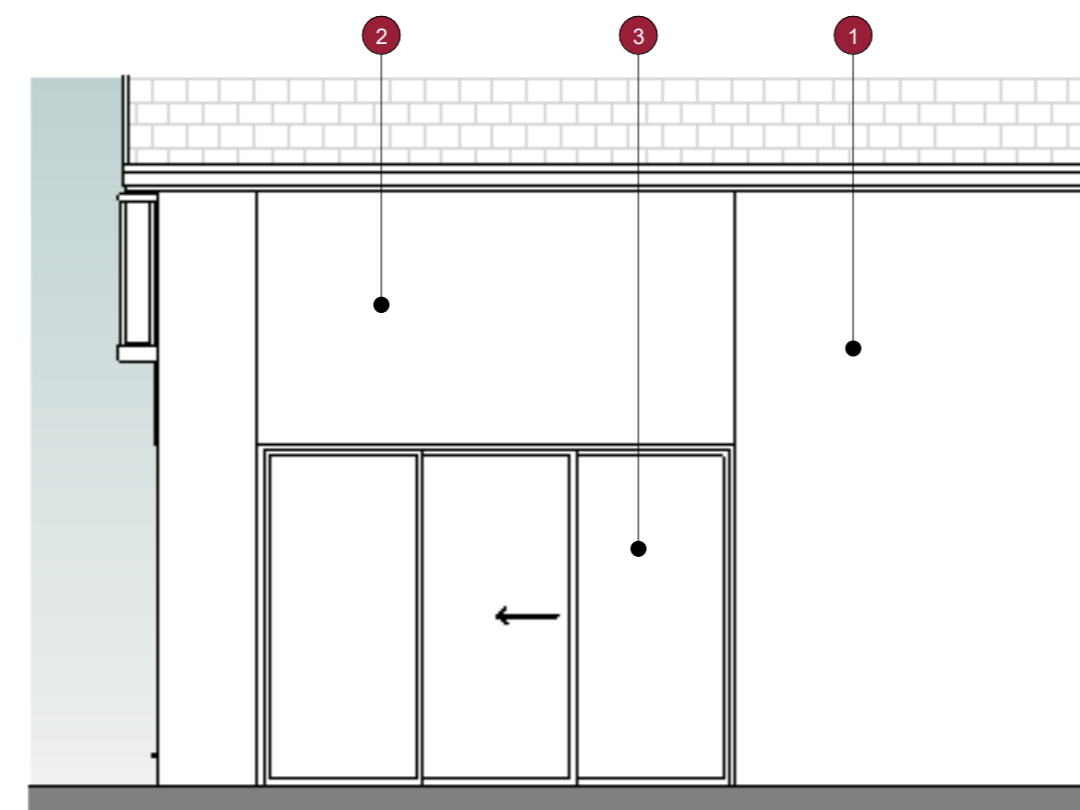

Existing South Elevation
1 : 50

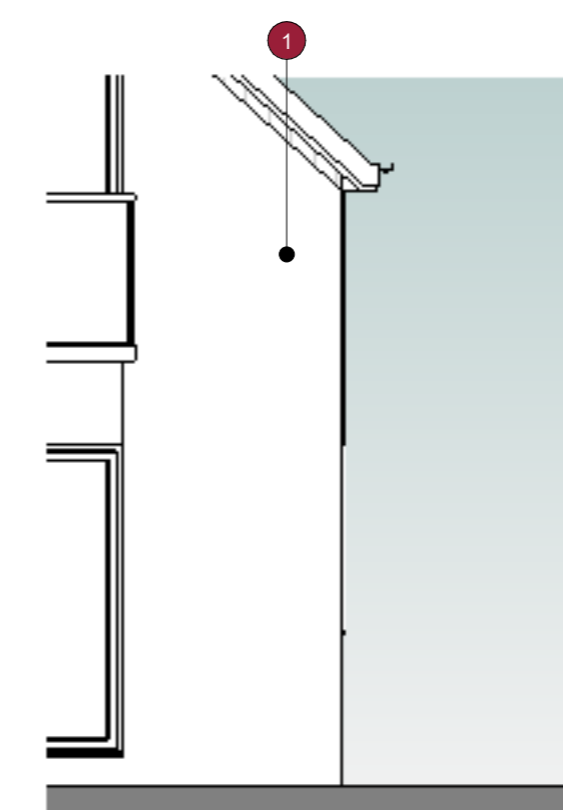

Existing West Elevation
1 : 50



Figure 2

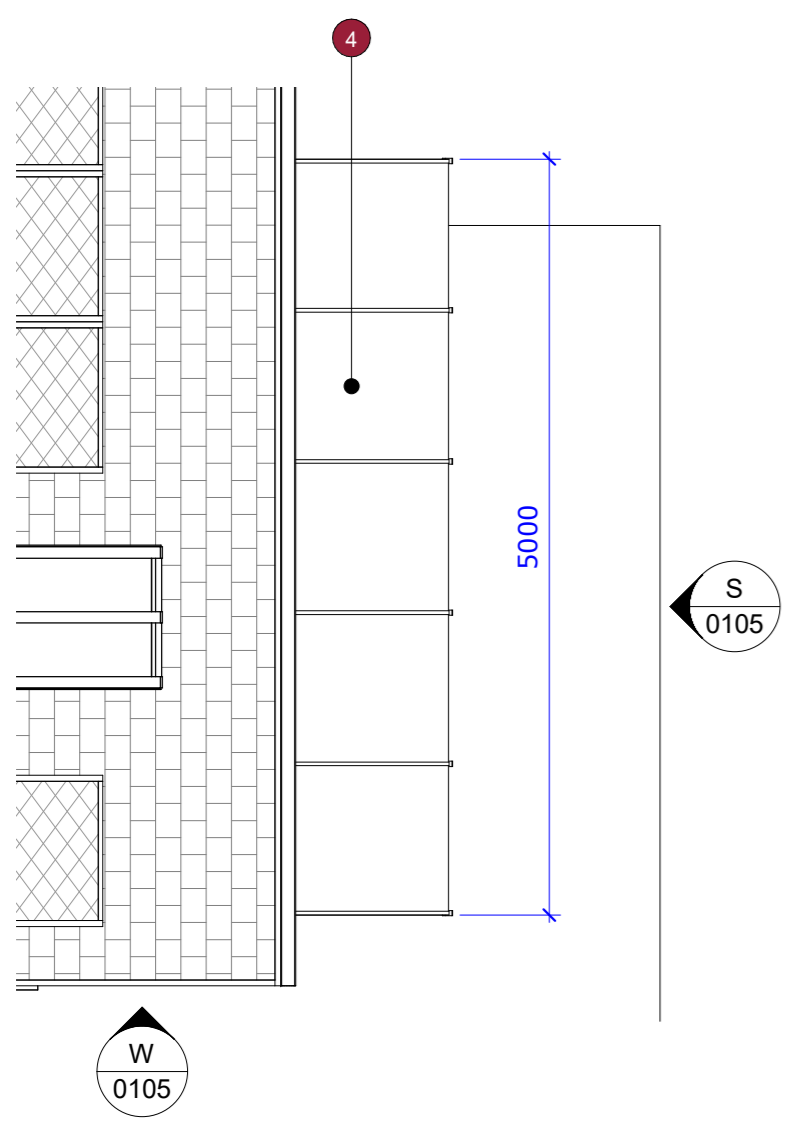

Proposed Solar Canopy Plan
1 : 50

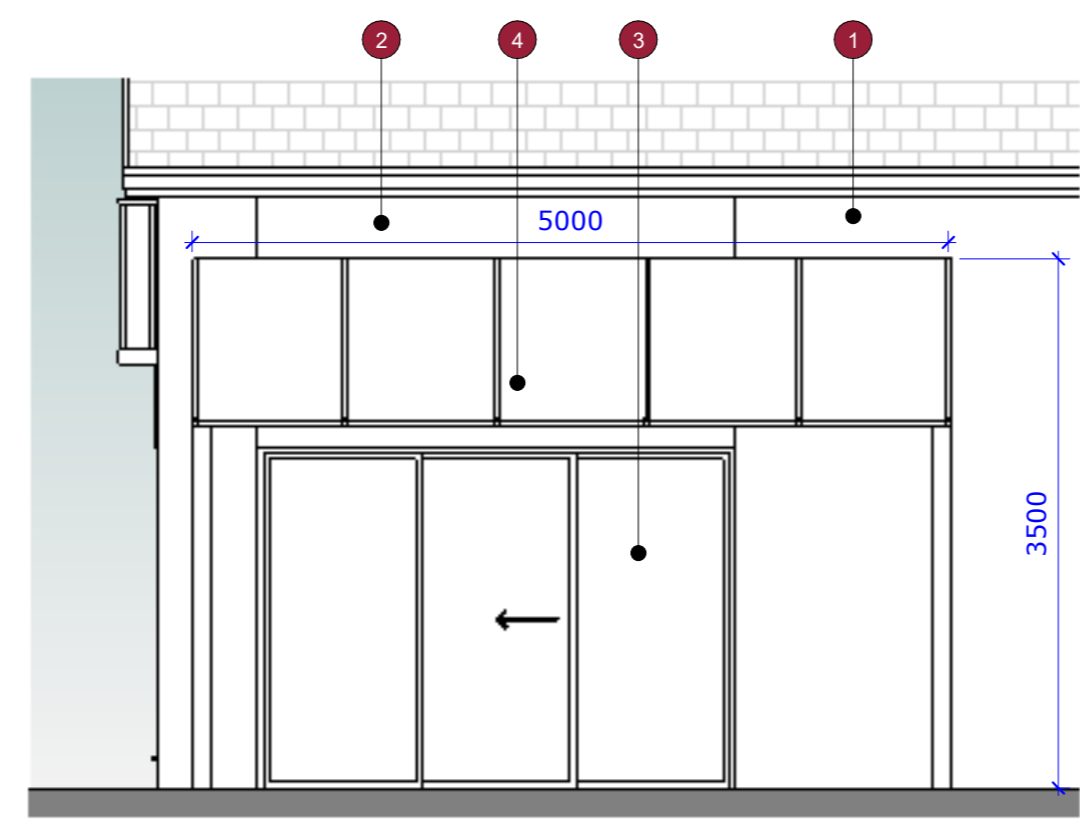

Proposed South Elevation
1 : 50

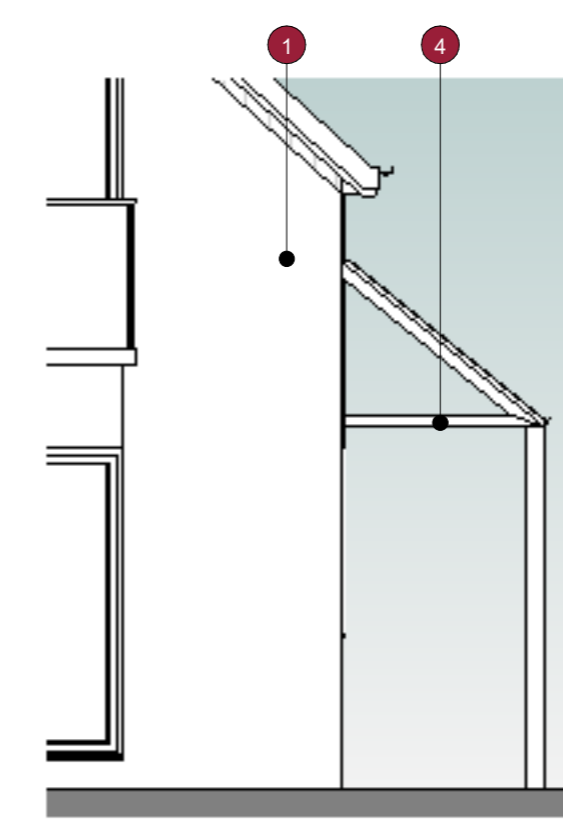

Proposed West Elevation
1 : 50

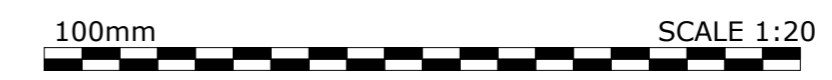

P02	SH	RB	RB	27/07/22
Solar Canopy updated				
P01	SH	RB	RB	24/06/22
Initial Issue				
Rev	Drawn By:	Checked By:	Approved By:	Date:
Amendments				
Project: Workshop / Store Stonelea Cottage, North Rauceby				
Title: Proposed Solar Canopy Plans and Elevations				
Drawing Number:				
Identification / Location: Sheet Number:				
Project Code:	Originator Code:	Vol / Zone:	Level:	Type: Dis: Number:
STONE	BED	ST	ZZ	DR A 0105
Rev Description:	Status Code:	Model Ref:	Rev No:	
Preliminary	S1	0001	P02	
Scale:	Sheet:	Discipline:	BED Project Number:	
1:50	A2	Architectural	NWK 130033	
Client:				

Mr & Mrs Enstone