

South Elevation

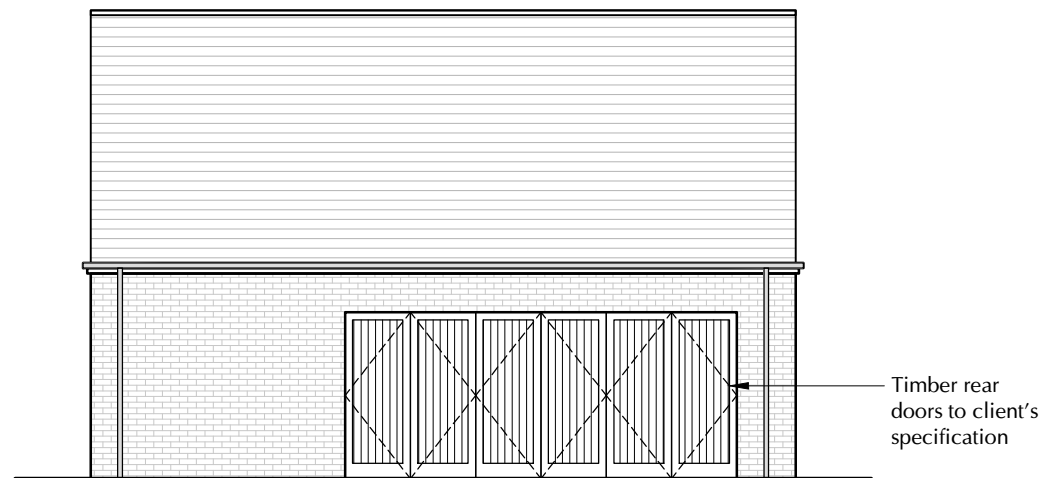

North Elevation

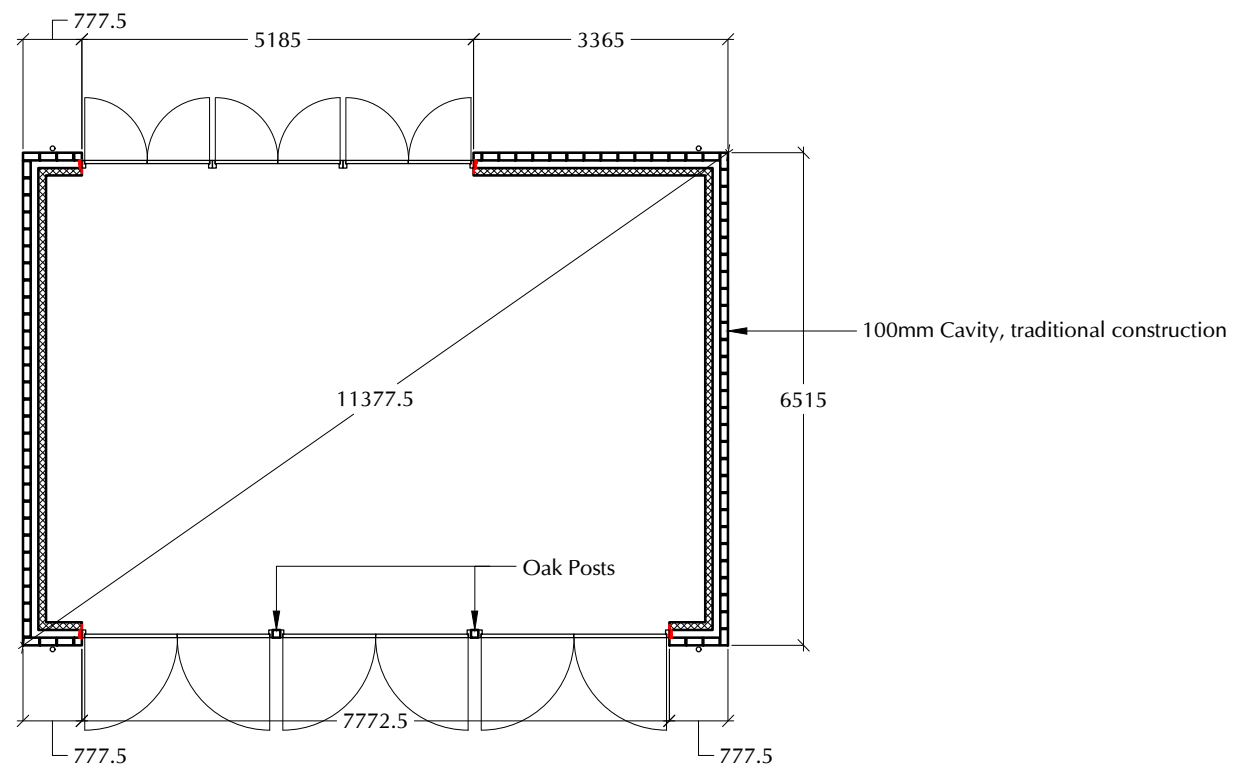

Floor Plan

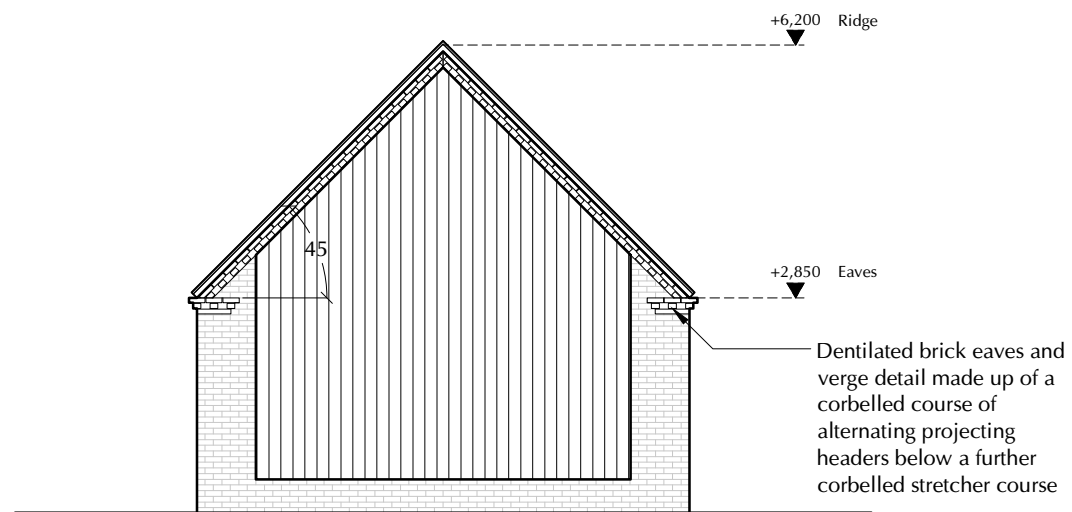

East and West Elevation

Legal Info

1. GRDA Consultant Architects. Do not scale from this drawing in either paper or digital form. Use written dimensions only. All dimensions are given in millimeters unless otherwise stated.
2. All survey information by others. Check all dimensions on site. Site boundaries to be confirmed by client solicitors with reference to title deeds.
3. This drawing is intended for use by the commissioning client only. RDA do not assume any liability to any third party for the information herein.
4. This drawing is to be read in conjunction with all relevant engineer's and specialist designers' drawings and specifications.
5. All demolition works subject to statutory approval and assessment by structural engineer.
6. Works covered by pre-commencement conditions or works without consent must NOT be carried out without statutory approval.
7. All specific drawing notes are to be read in conjunction with the project Health & Safety "Information Pack" and "Site Rules".

REVISIONS

-	15/09/22	SC
First Issue		
A	15/09/22	SC
Revised per client alterations		

JOB TITLE

High Thorpe

DWG TITLE

Garage Block

DATE	BY	CHECKED BY	
15/09/22	SC	-	A3
DWG NO.	REV.	STATUS	
2878(20)005	A	Stage 4	

RaynerDaviesArchitects

Nottingham | Kent

2 St. Peter's Gate
Nottingham
NG1 2JG

01159473859
www.rd-architects.co.uk

