

### Existing Site Plan

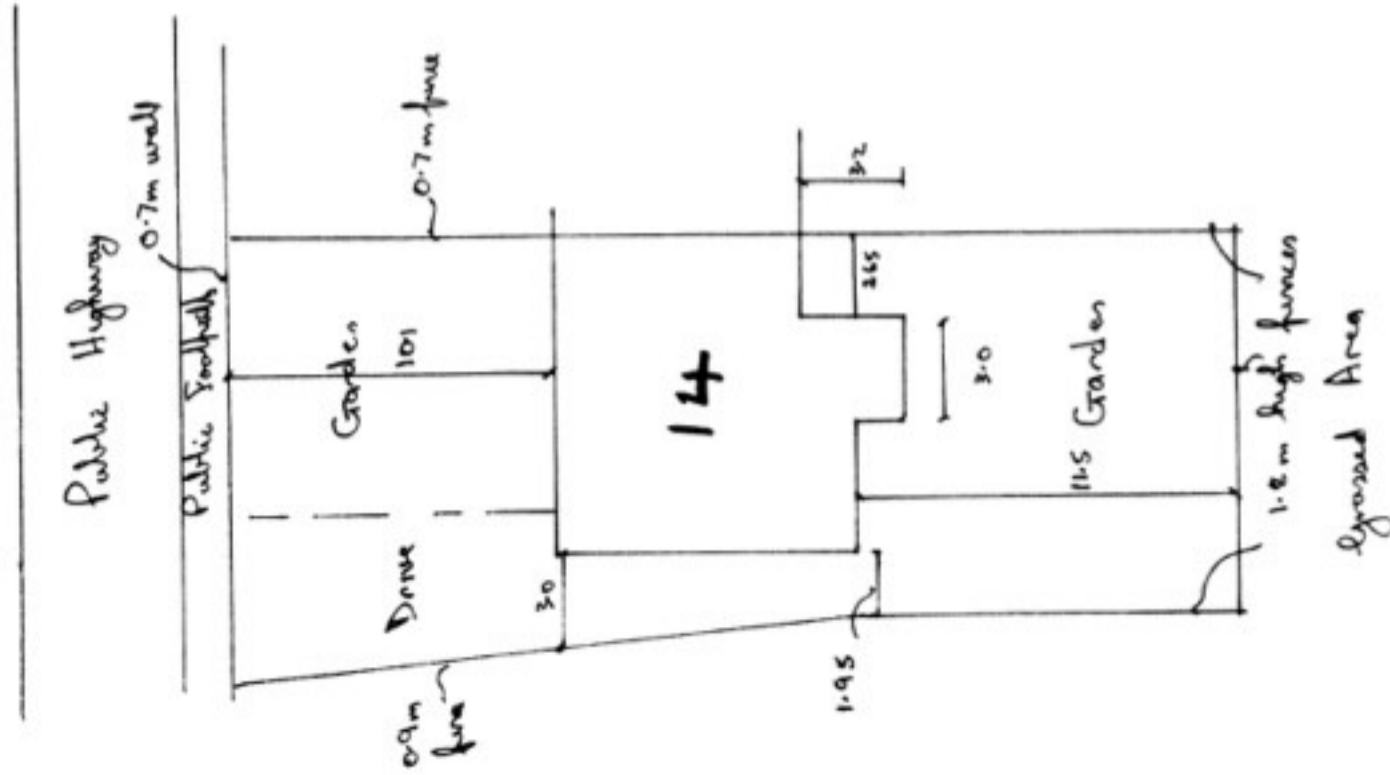

### Proposed Site Plan

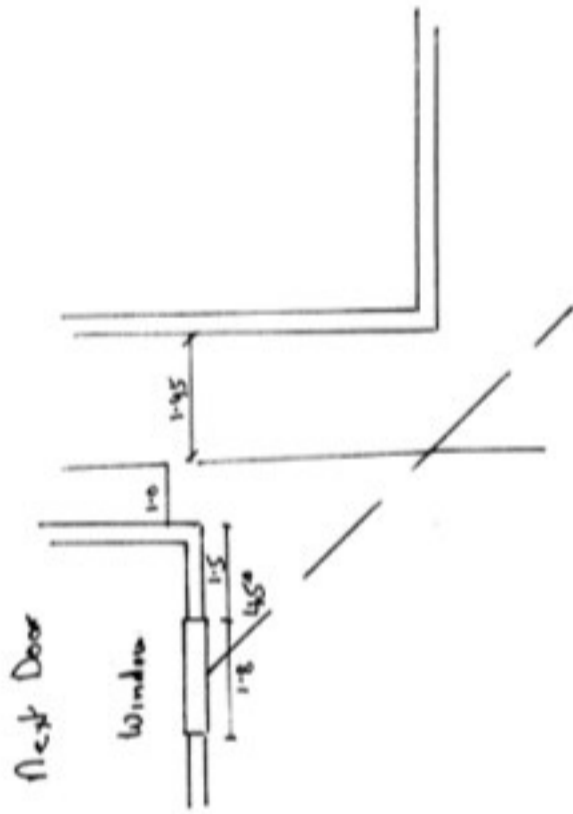
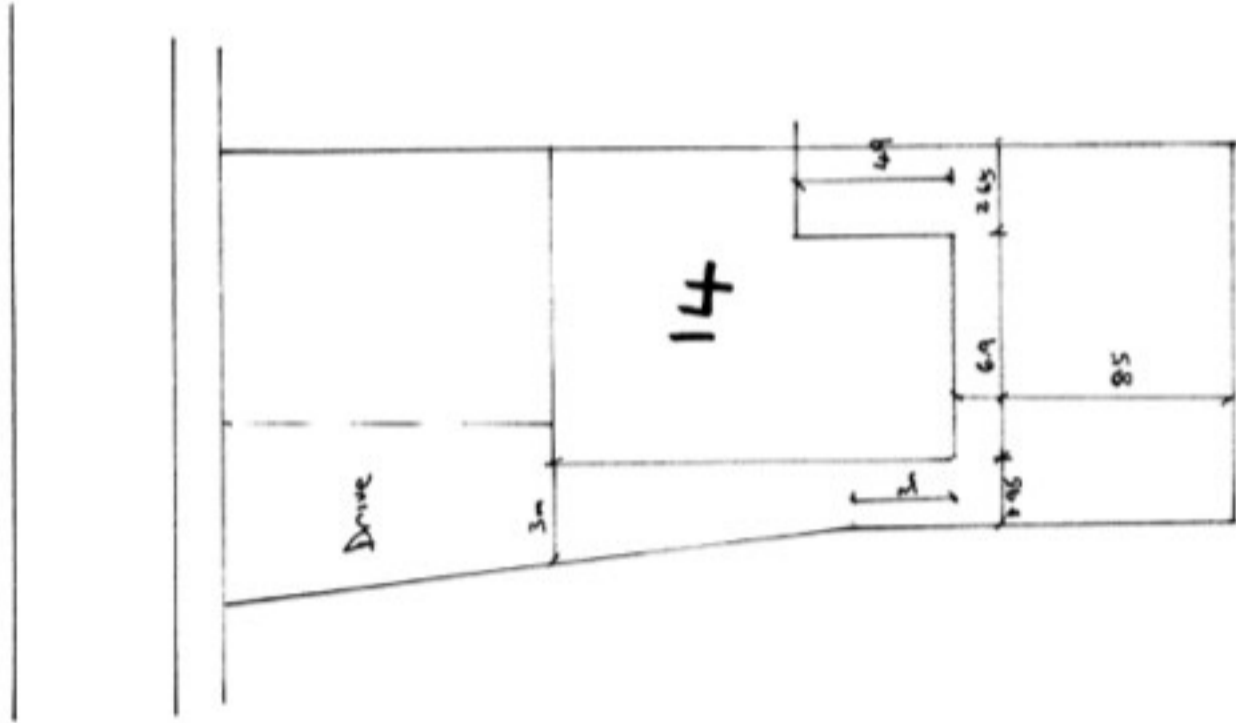

### Next Door Window Sizes

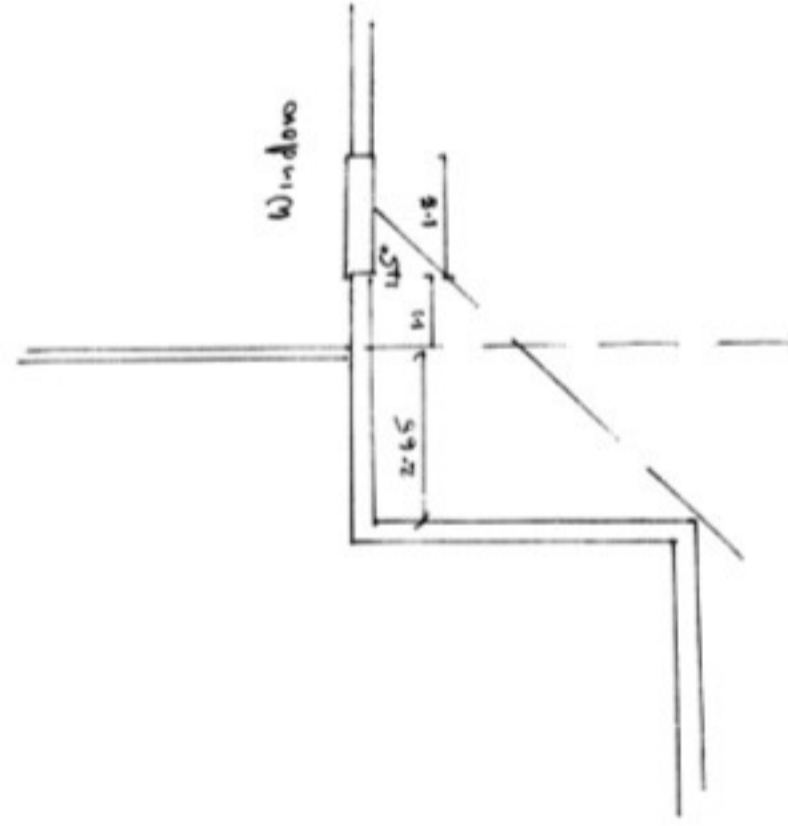

### Adjoining Window Sizes

: There are no trees on the site or adjoining land which could affect the development

: Boundary and boundary conditions will remain as existing

: Car Parking will remain as existing

NB 2nd floor plans indicate the size of the extension and the distance it is away from the centre of the nearest neighbour windows measured at 45° angle

14 Lincoln Crescent

Site Plan 1:200

Floor layouts 1:100