

WF1, WF2, WF3, & WF4

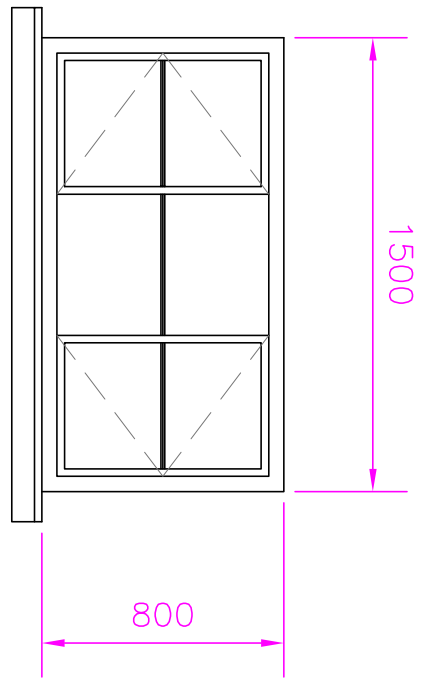

WF5

**For section detail refer manufacturer's drawings.
DIMENSIONS MUST BE TAKEN ON SITE.**

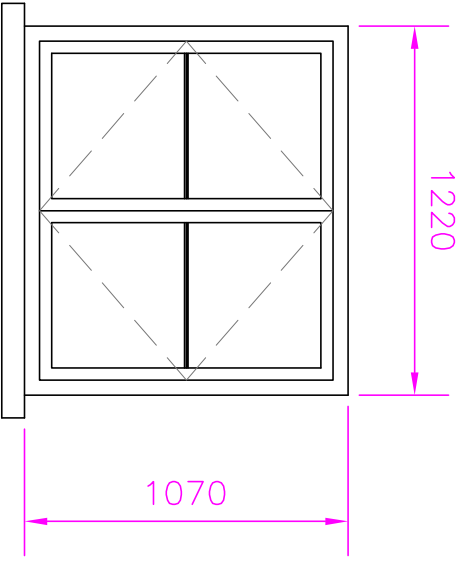

WG1

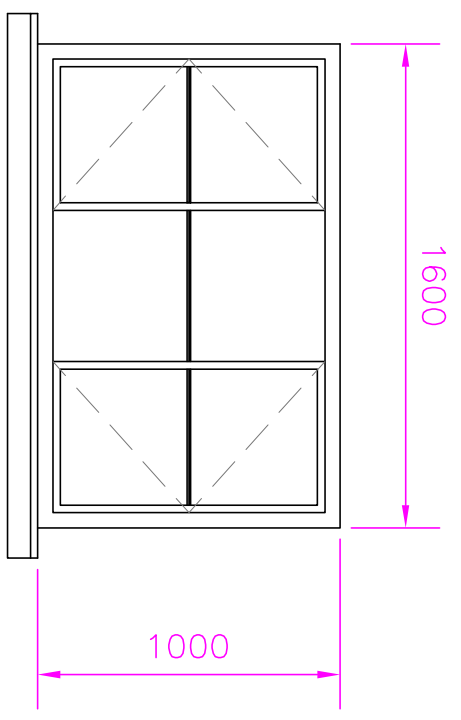

WG2

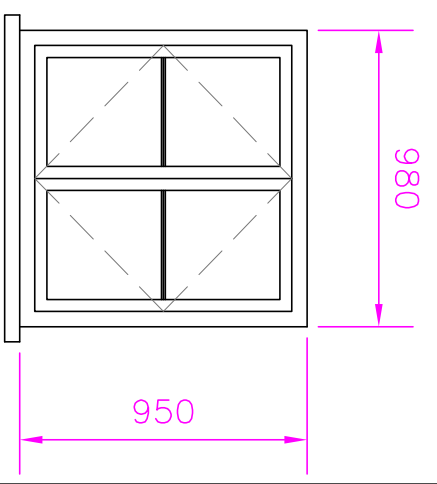

WG3

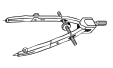

S.A.B. DRAWING & DESIGN
26 MARGUERITE ROAD TIVERTON DEVON
UNITED KINGDOM EX16 6TD
TEL: +44 (0) 1884 254004
E-Mail: steve@sabdrawings.com

COPYRIGHT.
COPYRIGHT OF THIS DRAWING
AND ANY WORKS EXECUTED
FROM THIS DRAWING UNLESS
OTHERWISE AGREED IN WRITING
IS RESERVED TO S.A.B. DRAWING
& DESIGN.

Rev	Date	Revision

TITLE
PROPOSED NEW ROOF (ATTACHED OVER REAR SINGLE
STOREY REPLACING EXISTING ROOF (FLAT) & NEW
WINDOWS.
PROPOSED WINDOWS

CLIENT
MR BONNILL
WESTWAY HOUSE
WAY VILLAGE
TIVERTON
EX16 6LX

DRN. SAB
DATE 03.10.22
SCALE A4 1:250

DRG. No.
01755/8
Rev. 1 (03.10.22)