

To check this drawing has been printed to the intended scale this bar should be 25mm long

- NOTES:**
1. This drawing is copyright of Studio 27 Architects.
 2. Do not scale from this drawing, work to figured dimensions only. Notify any discrepancies to the Architect / Contract Administrator prior to commencing any work.
 3. All levels are in metres above ordnance datum. All dimensions are in mm (u.n.o.).
 4. The Contractor is responsible for coordinating all aspects of the Works, including Sub-contractors Works.
 5. All proprietary systems to be installed in strict accordance with the manufacturer's recommendations.
 6. For ordnance survey coordinates and setting out refer to setting out drawings.
 7. The Contractor is responsible for the design and detailing of all temporary works.
 8. This drawing is to be read in conjunction with all other associated project documents including drawings, models, specifications, schedules and related consultants' documents.

HEALTH & SAFETY INFORMATION:

In addition to the hazard/risks normally associated with the types of work detailed on this drawing take note of the hazards listed below. It is assumed that all works on this drawing will be carried out by a competent contractor working, where appropriate, to an appropriate method statement.

Date	Rev	By	Details
29/03/2022	01	DE	Planning Issue - Pre-app advice
24/11/2022	02	DE	Planning application issue

LOCATION KEY



Planning

STUDIO 27
architects®

Bromsgrove (Head Office):
The Studio, 27 Gleneagles Drive, Blackwell,
Bromsgrove, B60 1BD
Tel. 0121 445 1846

Shipston-On-Stour:
1st Floor, The Mill, Mill Street
Shipston on Stour, CV36 4AW
Tel. 01608 662 020
mail@studio27.org.uk

Project
New Stables
Firs Cottage, Haseley Green CV35 7LT

Client
Mr J Smith

Drawing Title
Plan and Elevations - Proposed

Date	Scale	Checked
24/11/2022	1:100 @A3	BF
Project Ref.	Drawing No.	Revision
22-5722	111	02

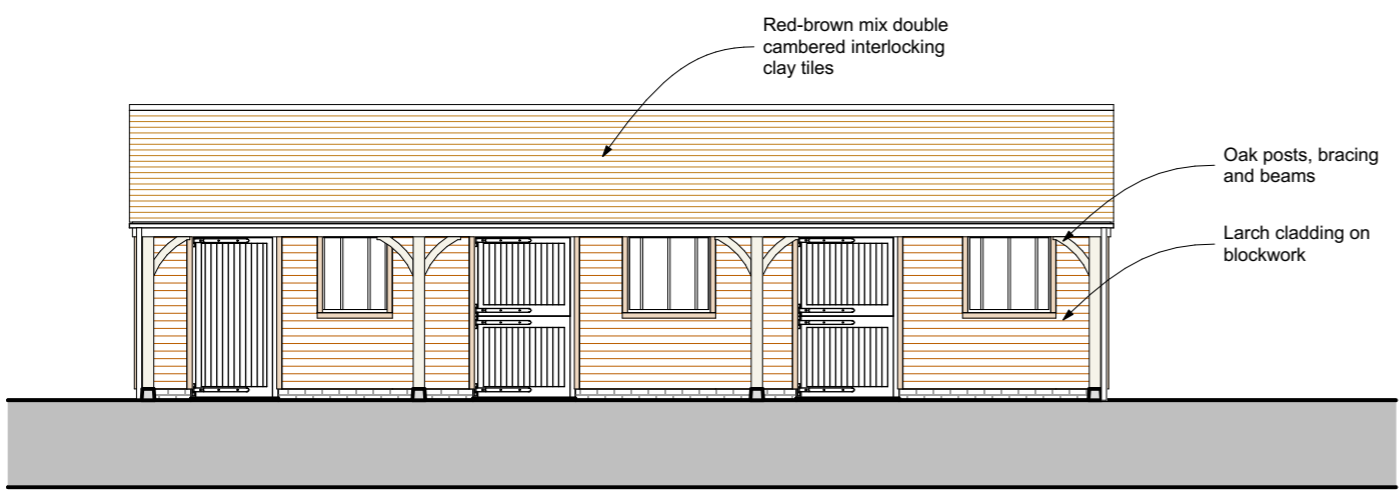

2 South Elevation Proposed 1:100

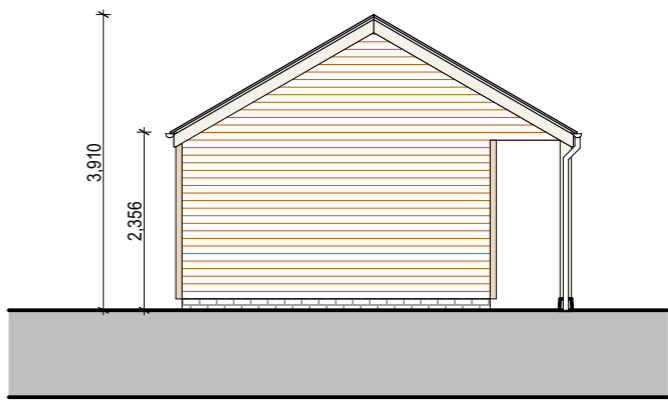

3 West Elevation Proposed 1:100

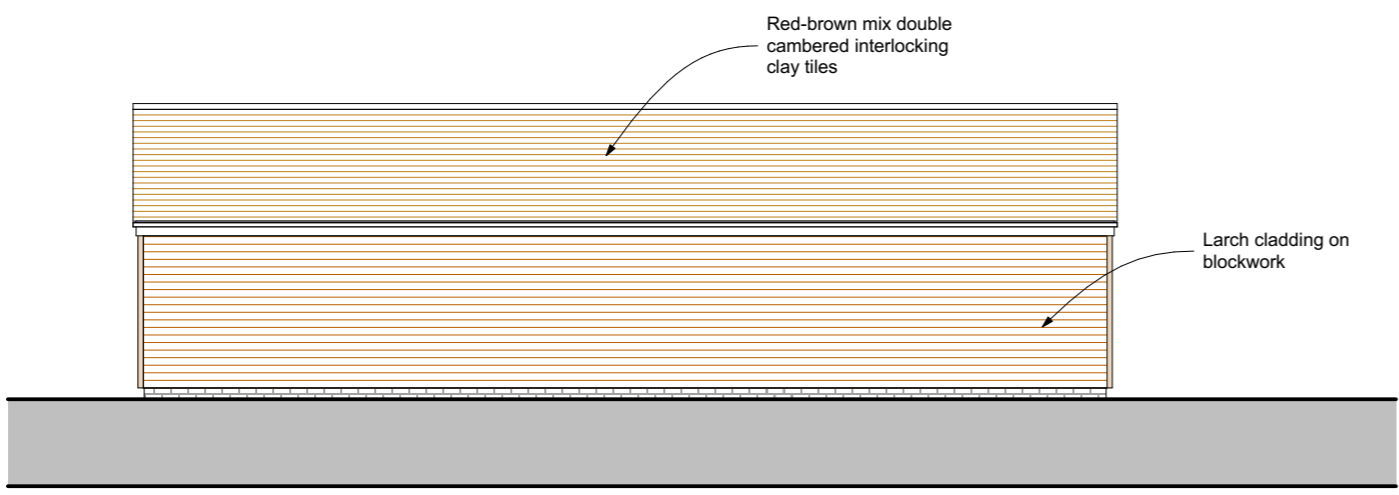

4 North Elevation Proposed 1:100

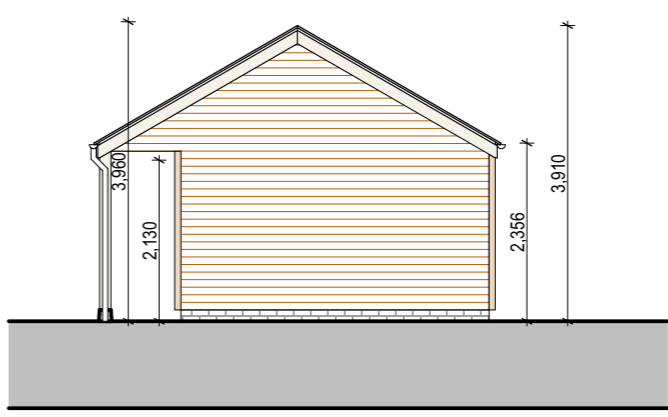

5 East Elevation Proposed 1:100

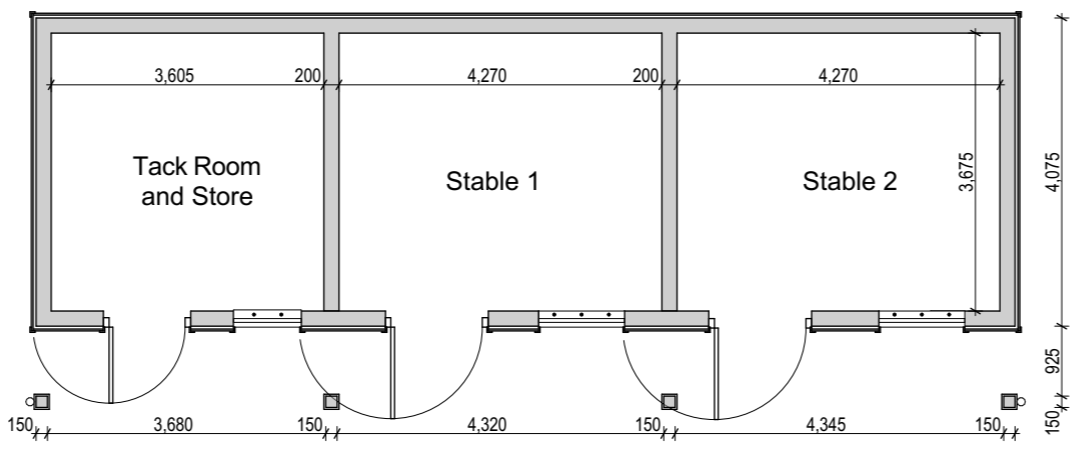

1 Floor Plan Proposed 1:100