

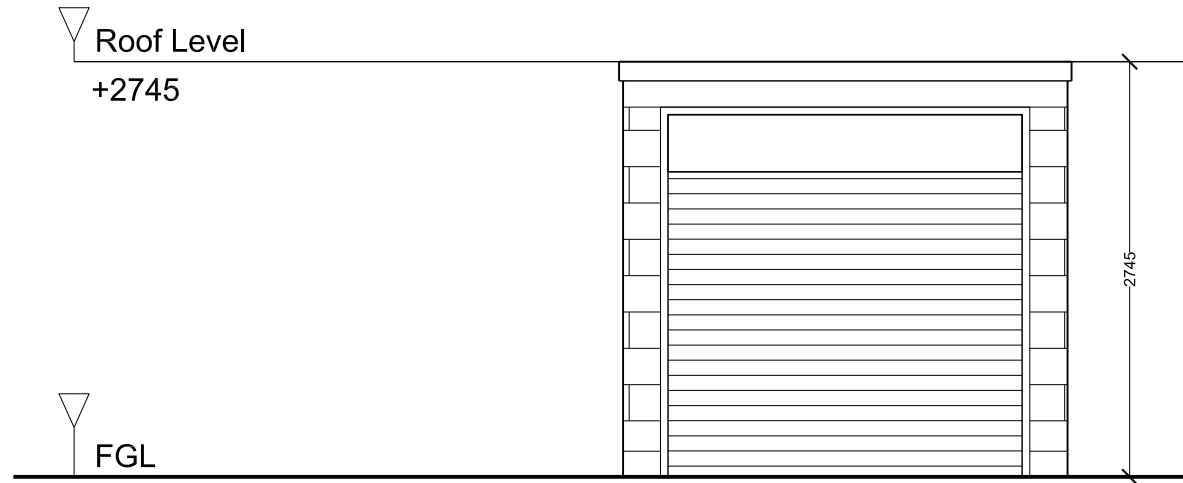

Notes:

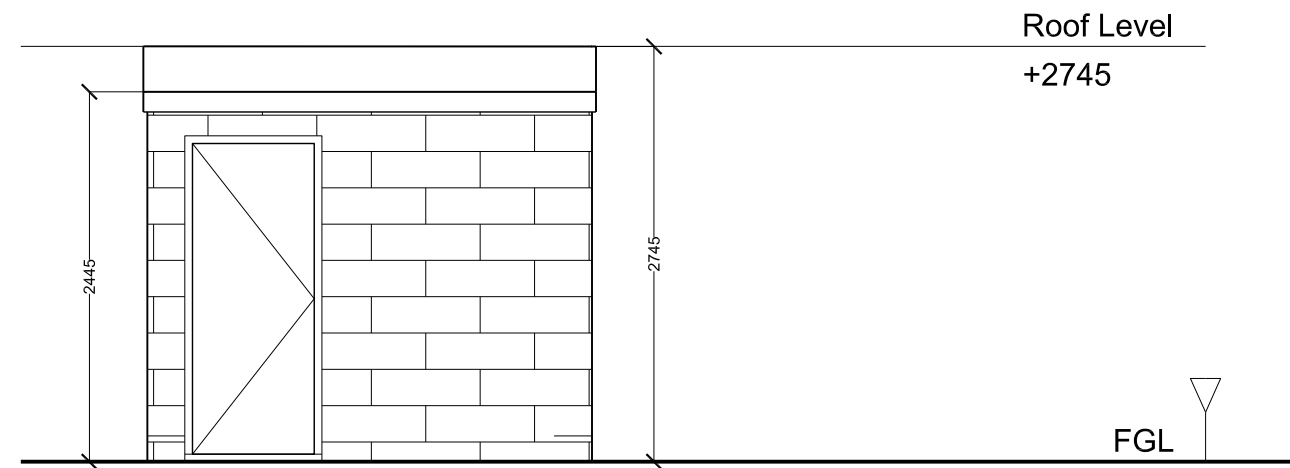

Existing South Elevation 1:50



Existing North Elevation 1:50

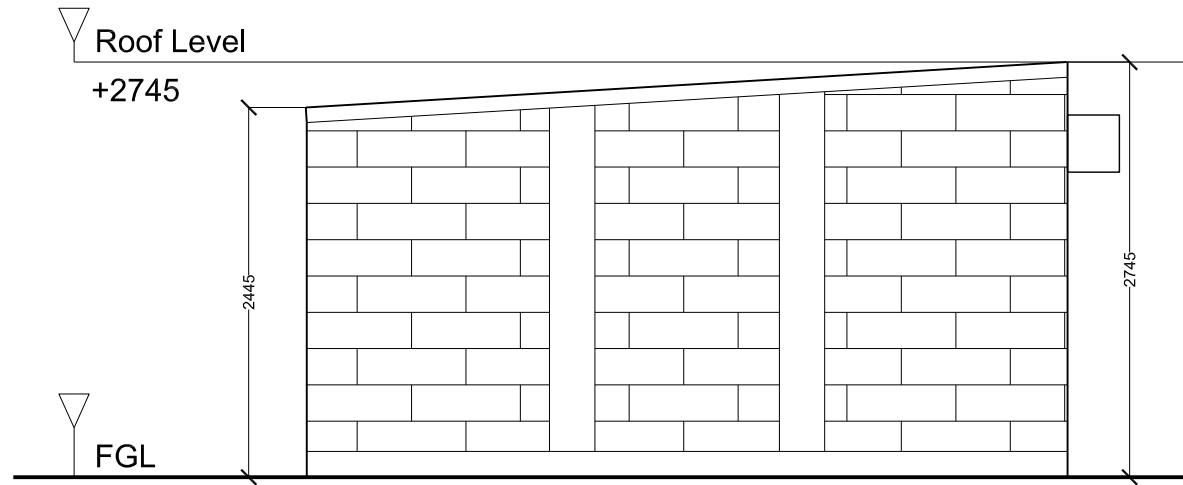

Existing West Elevation 1:50

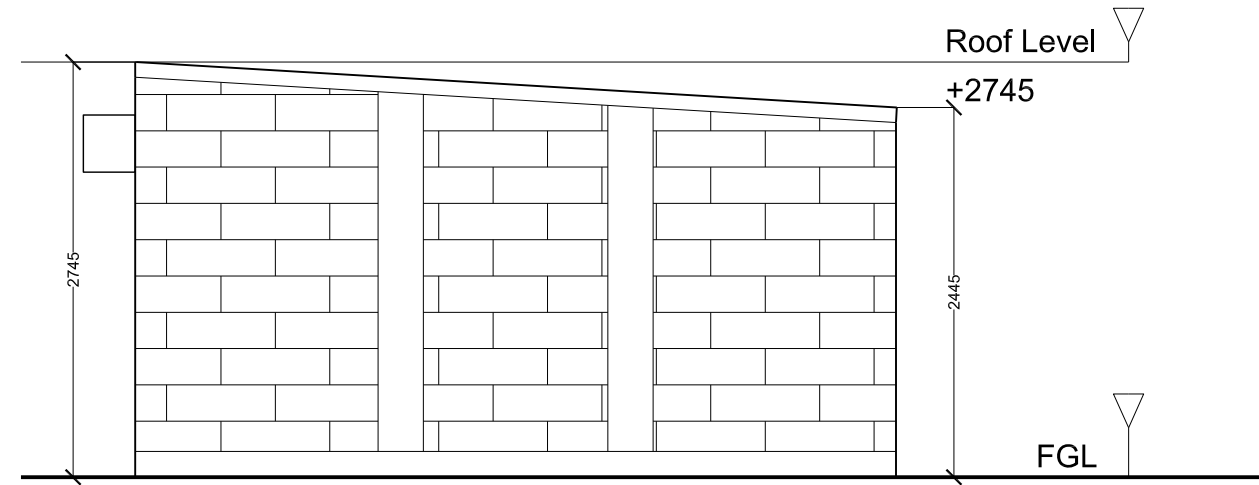

Existing East Elevation 1:50

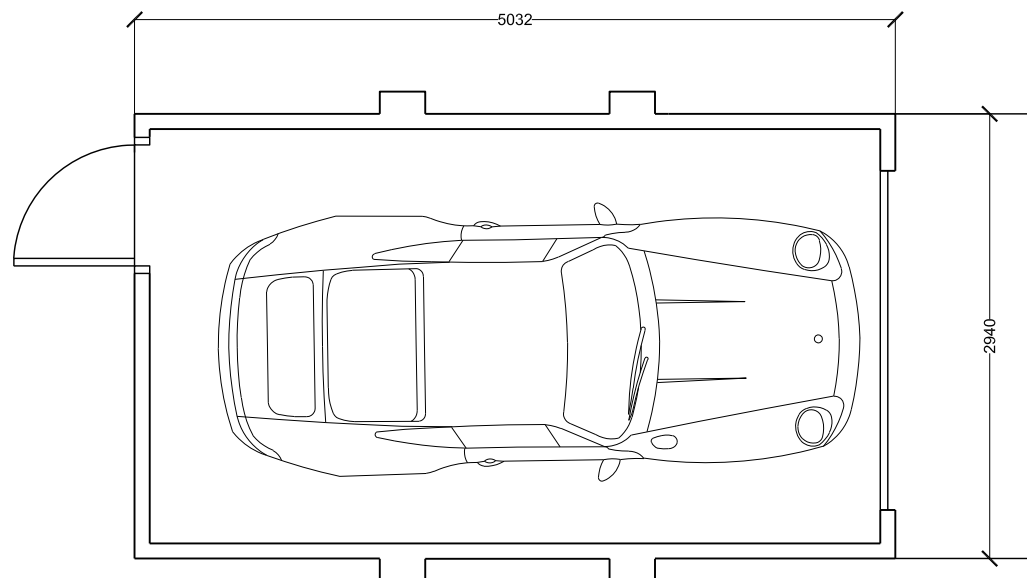

Existing Ground Floor Plan 1:50

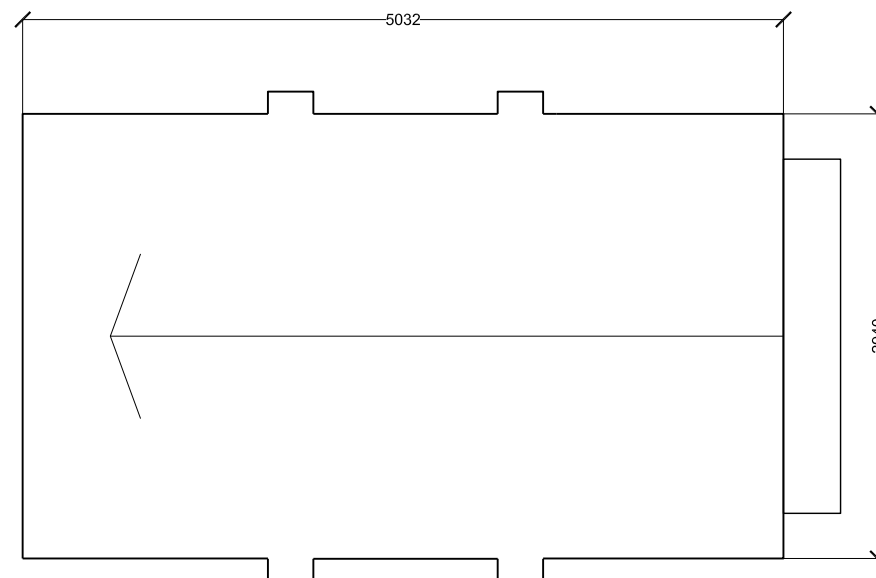

Existing Roof Plan 1:50



Revision: 2 Date: 12/09/22 Drawn By: CS

North point and scale bar added

Revision: 1 Date: 11/08/22 Drawn By: CA

First Issue

The use of this data by the recipient acts as an agreement of the following statements. Do not use this data if you do not agree with any of the following statements- All drawings are based upon site information supplied by third parties and as such their accuracy cannot be guaranteed. All features are approximate and subject to clarification by a detailed topographical survey, statutory service enquiries and confirmation of the legal boundaries. Do not scale the drawing, use figured dimensions in all cases, check all dimensions on site. Report discrepancies in writing to GRADONARCHITECTURE before proceeding. COPYRIGHT GRADON ARCHITECTURE 2015. NOT TO BE REPRODUCED WITHOUT THE WRITTEN AUTHORITY OF THE ARCHITECT.

Status
Planning

Project
McPherson Residence
6 Laburnam Terrace Wylam

Drawing
Existing Garage Floor Plan and Elevations

Project No. Drawing No.
GRA-671 100:04

Scale at A3 Drawn By
1:50 CA

