

Street Farm,
The Street,
Brent Eleigh,
Suffolk

Design and Access Statement
Proposed Pool

June 2023

**project
orange**





Introduction

The application proposes an external swimming pool to an existing grade II listed farmhouse dwelling on Street Farm. A previous planning application has been granted for a single story extension connected to the north wing of the main dwelling (REF: DC/22/00138). This proposal locates the pool directly north of the extension adjacent to the existing sunken terrace of the extension. A low brick wall is proposed to form an enclosure for the pool.

The applicants also own a Cafe and secondary ancillary buildings which are within the site and located west of the dwelling.

Site Address:
Street Farm,
The Street,
Brent Eleigh,
Suffolk,
CO10 9NU

project orange

Project Orange is an award winning architecture and interior design practice with a broad and original portfolio of work in the UK and overseas. Established in 1997, the practice excels in projects that seek a seamless marriage of architecture and interior design.

Hidden House,
Hall Road,
Lavenham
Suffolk
CO10 9QU

020 7739 3035
www.projectorange.com

Ariel View



Site Photos



1. View of existing farmhouse dwelling from rear garden
2. View of formal house frontage from The Street.
3. View of north facing elevation from existing north west hedging.
4. View towards south axis of north facing elevation from rear garden
5. View of proposed area for new pool.
6. View of existing timber gate accessing The Street.

Materials



1. Red brick wall enclosure to match existing extension & retaining walls
2. Black pool lining (in-use)
3. Black pool lining (material)
4. Tumbled sandstone paving

Appendix

22 March 2023

Mrs. M. Elgar
Street Farm
The Street
Brent Eleigh
CO10 9NU



Letts Swimming Pools Limited

Design, construction & equipment specialists

Semer, Ipswich, Suffolk IP7 6HP

Tel: 01473 822375

Fax: 01473 824223

QUOTATION & SPECIFICATION – V3

<u>TYPE</u>	Concrete Walled Liner Pool								
<u>SHAPE</u>	Rectangular Flat Floor								
<u>DIMENSIONS</u>	<table border="0"> <tr> <td>Length</td> <td>12m</td> </tr> <tr> <td>Width</td> <td>3m</td> </tr> <tr> <td>Depth of pool water</td> <td>1.4m</td> </tr> <tr> <td>Approximate capacity</td> <td>50,000 Litres</td> </tr> </table>	Length	12m	Width	3m	Depth of pool water	1.4m	Approximate capacity	50,000 Litres
Length	12m								
Width	3m								
Depth of pool water	1.4m								
Approximate capacity	50,000 Litres								
<u>LEVEL</u>	To be agreed on site, but it is assumed it will be average ground level or just above.								
<u>EXCAVATION</u>	To be completed using a tracked excavator to create the least damage to the surrounding area as possible. See additional cost for carting and landscaping of excavated soil under extra's.								
<u>CONSTRUCTION</u>	Make provision for drainage under pool, if necessary.								
<u>Pool Floor</u>	Lay 75 mm concrete base and finish with sand / cement screed.								
<u>Wall Footings</u>	Construct steel reinforced concrete footings.								
<u>Pool Walls</u>	Construct with hollow wall shuttering and fill with concrete.								
<u>Coping Stones</u>	Lay 300 mm wide riven sandstone edgings. Cost allowed of [REDACTED] See extra cost for sawn Sandstone and Limestone.								

22 March 2023

INTERNAL FINISH

<u>Walls</u>	Sand / cement render
<u>Floor</u>	Sand / cement screed on lean-mix base.
<u>Pool Liner</u>	Fit 0.75mm fully patterned liner.

POOL FITTINGS

The following are built into the pool shell during construction and plumbed back to the filter plant.

<u>Suction Points</u>	2 Sump Pots set in floor at bottom of deep end,
<u>Surface Water Skimmer</u>	1 set at water level to remove debris etc.
<u>Inlet Points</u>	2 set in long walls.
<u>Vacuum Point</u>	1 set in centre of long wall in case you require an automatic cleaner.

FILTRATION

Supply and install fibreglass rapid sand filter, using Advance Glass Media in your housing with self- priming pump. This will give a seven hour turnover.

Housing Not included.

Plumbing All pool fittings are connected to the filtration with A.B.S. pipes and fittings below ground including a valved manifold to the pump. It is assumed this is within 6 metres of the pool.
Pipes all fully pressure tested during installation.

Backwashing & Emptying.

To drain within 5m of the pump room. No additional cost.
OR
To soakaway constructed by ourselves, potential extra cost and licencing may be required. Appro [REDACTED]
OR
To water storage tank, to be used to water the garden once the low level of chlorine has dissipated. Approx [REDACTED]

22 March 2023

GENERAL

It is assumed that you (the customer) own the land on which the pool is to be constructed and that you will obtain any planning permission, building regulations approval, listed building consent or any other permissions and consents that may be required.

No responsibility undertaken for damage during access or for reinstatement around the pool or the approach. It is assumed you will clear the site of all existing shrubs, trees etc.

UNDERGROUND WATER

If there is a possibility of the ground water level rising to within 300mm of the finished paving level at any time of year this could cause the pool to lift, therefore consideration must be given to providing permanent land drainage from immediately beside the pool to a ditch or drain **at extra cost.**

UNKNOWN FACTORS

Should underground cables, pipes etc., be encountered and require diverting or repairing this would be charged extra, as would underground water or unstable sub-soil and any additional drainage.

PAYMENT TERMS

- 10% Deposit with order.*
- 40% on completion of concrete walls.*
- 20% on completion of pool shell and filtration equipment.*
- 20% on completion of all works.*
- Final 10% 1 month after completion.*

To carrying out all the foregoing work, including labour, plant, materials and transport as per our specification and plans.

FOR THE NETT SUM OF Was [redacted] for 11m pool [redacted]

This quotation is based on today's costings and will remain firm given instructions within 14 days, but after this would be subject to revision. All construction and filtration details comply with the *Standards of the Swimming Pool and Allied Trades.*

[redacted]

OPTION A

ONE PIECE HINGED LID
FELT COVERED WITH
STAYS TO HOLD THE LID OPEN

OPTION A - 2 DOOR

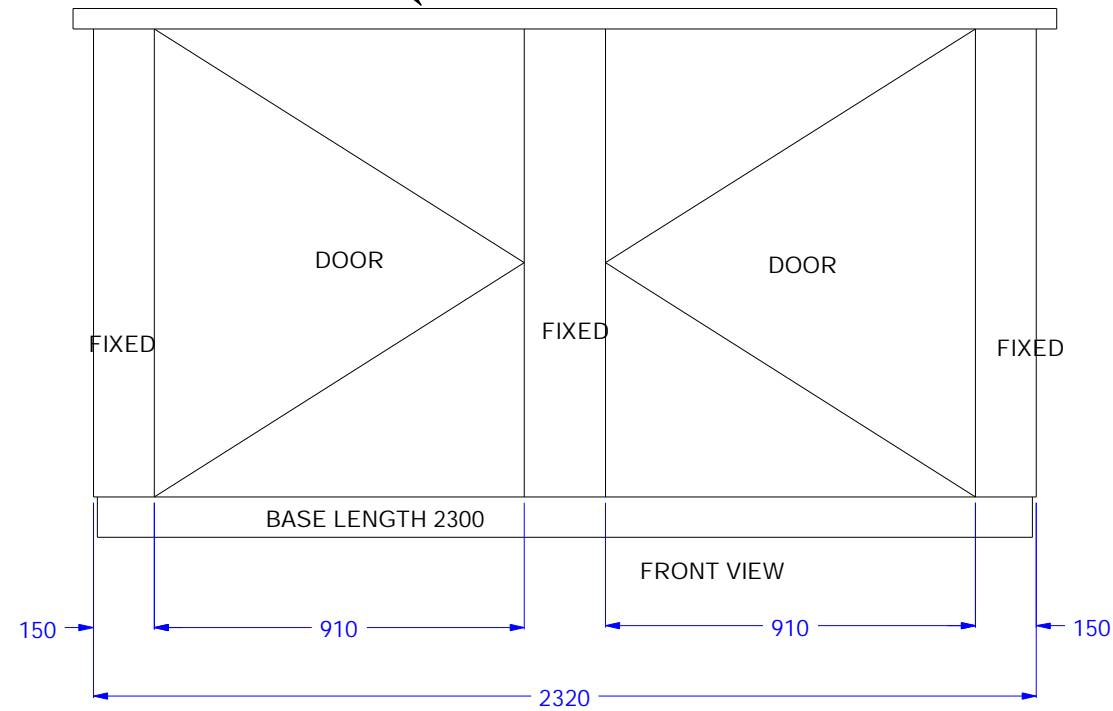

CATCH TO STOP LID
BLOWING OFF

HINGE FOR
SERVICE ACCESS

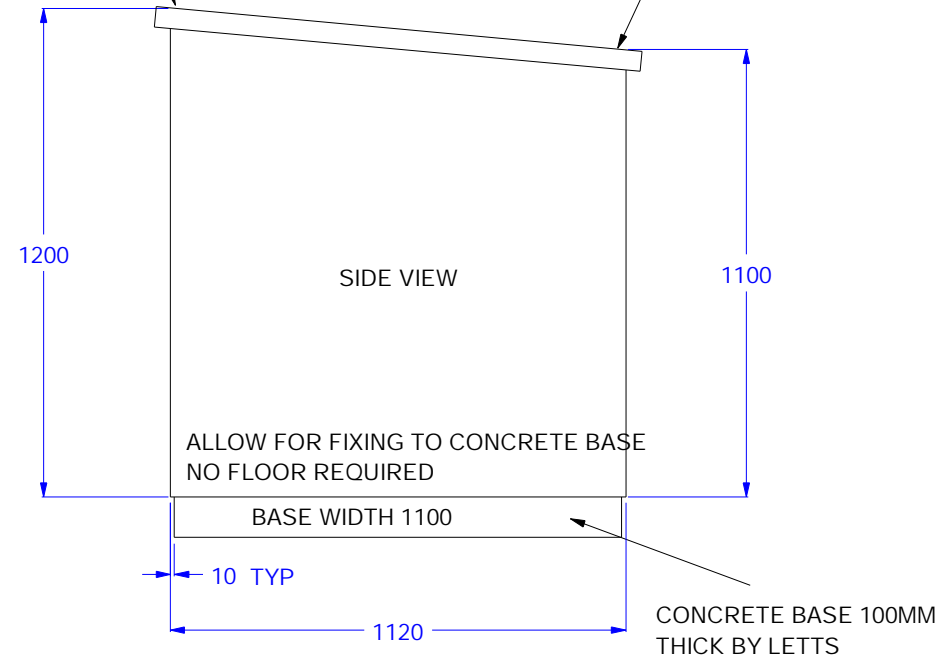

LOW LEVEL PLANT ROOM
OPTION A
TWO DOOR
WOODEN CONSTRUCTION
TREATED/STAINED
2" SQUARE FRAME
SHIPLAP CLADDING

LETTS SWIMMING POOL LTD
SEMER
IPSWICH
IP7 6HP
01473 822375
INFO@LETTSPOLS.CO.UK
DRAWN PR 26-05-2020 V2



**project
orange**