

ISO A1 594mm x 841mm  
 27.06.2022  
 Approver: DG  
 27.06.2022  
 Lead Verifier: GH  
 27.06.2022  
 Reviewer: KB  
 27.06.2022  
 Originator: JB  
 27.06.2022  
 Technical Quality Review Initials:  
 27.06.2022  
 Last Plotter: 2022-06-27  
 Filename: WELL-ISO1(2022-06-27)  
 Last Plotter: 2022-06-27

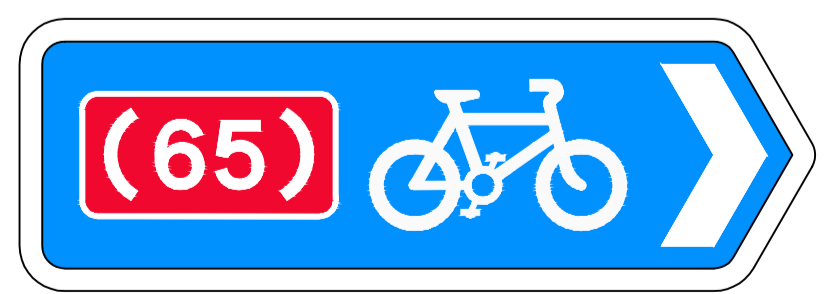

**PLAN 1**  
SCALE: 1:500

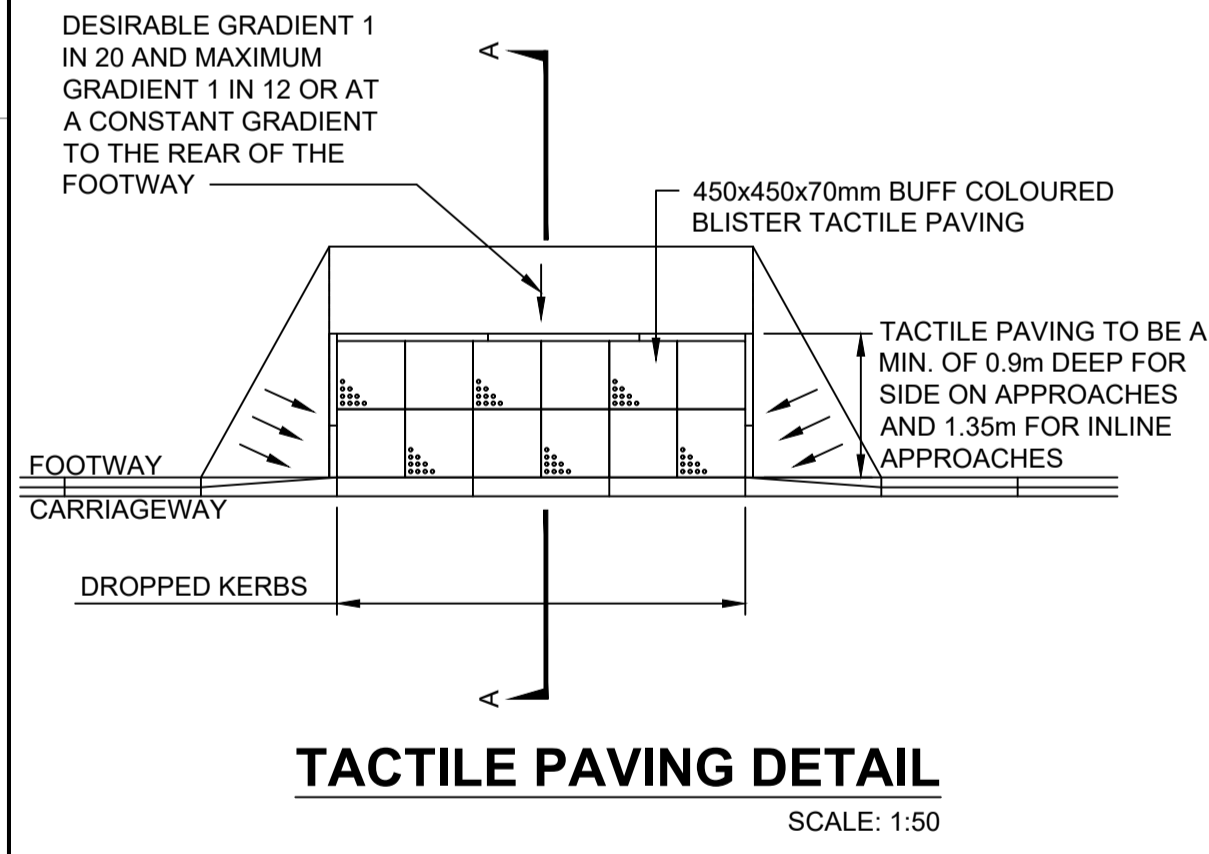

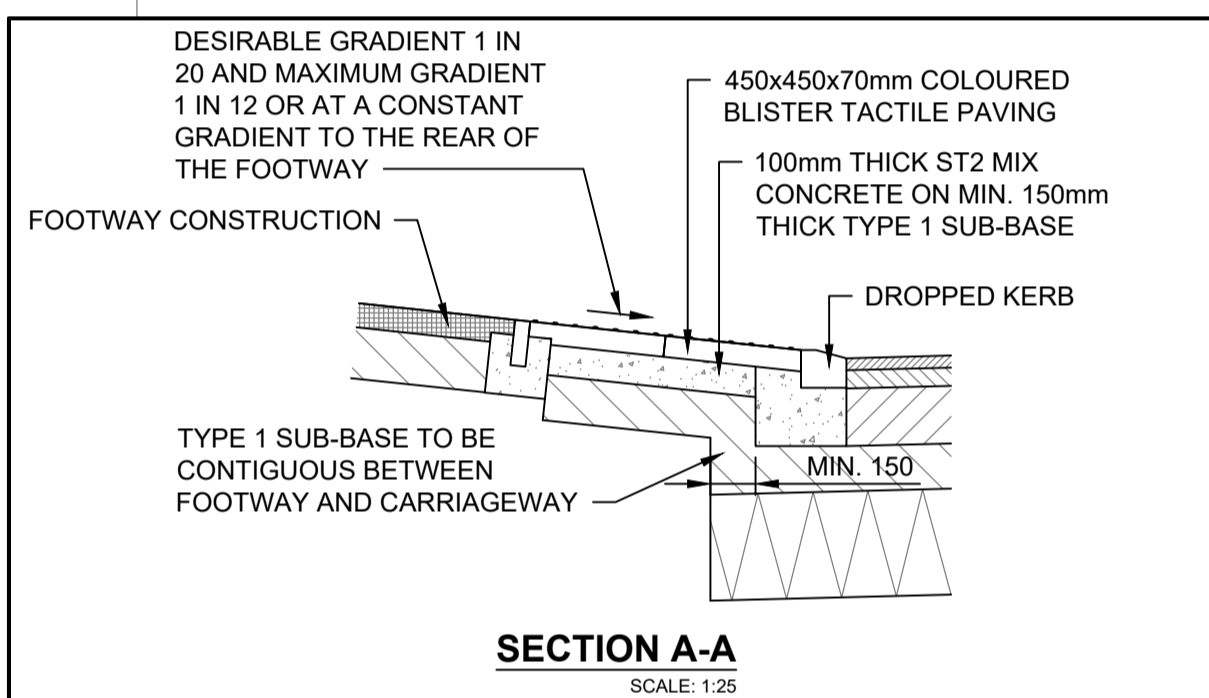
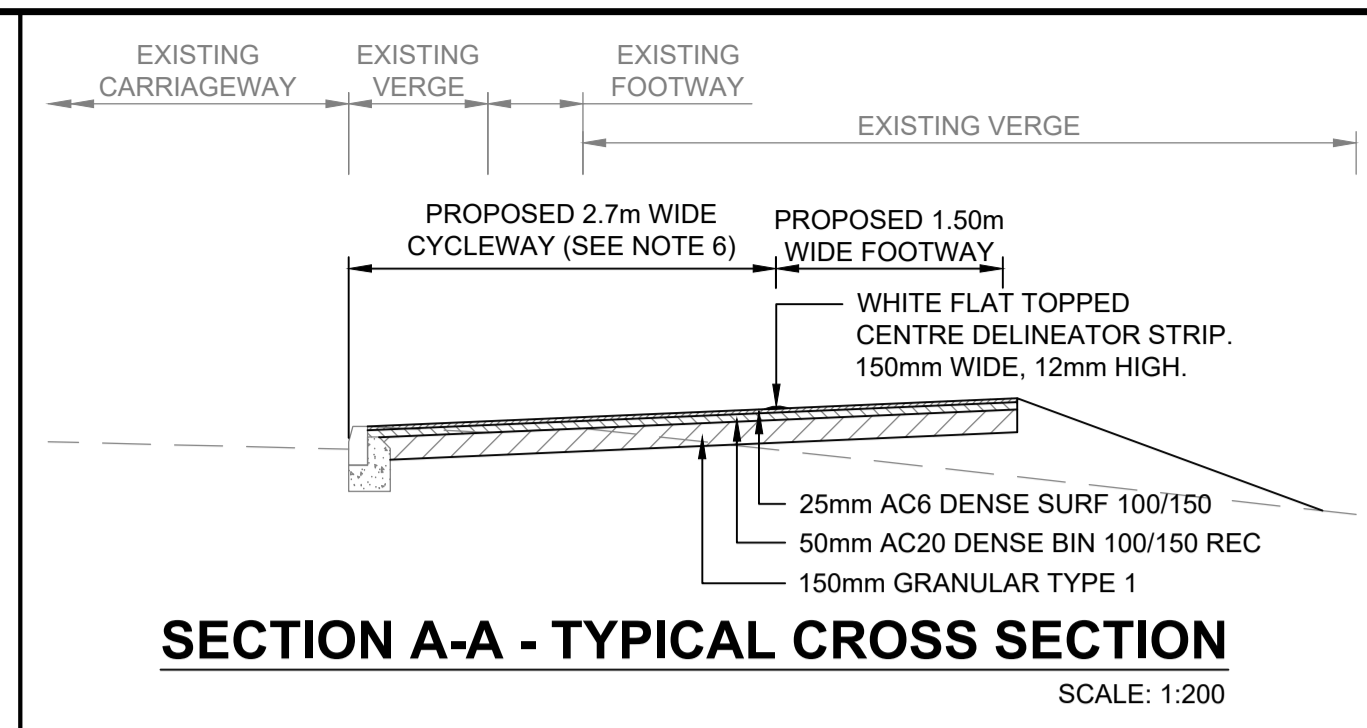
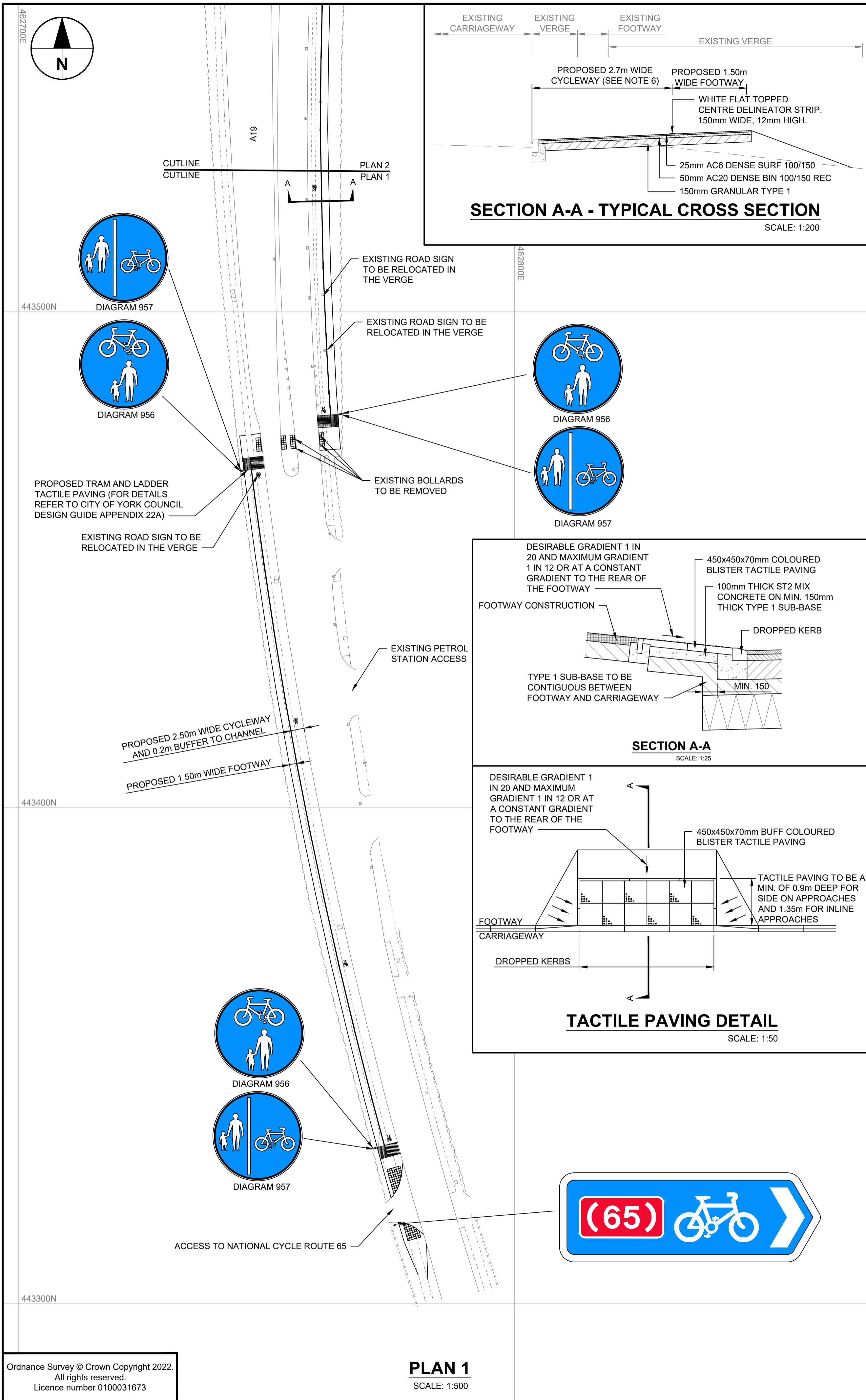
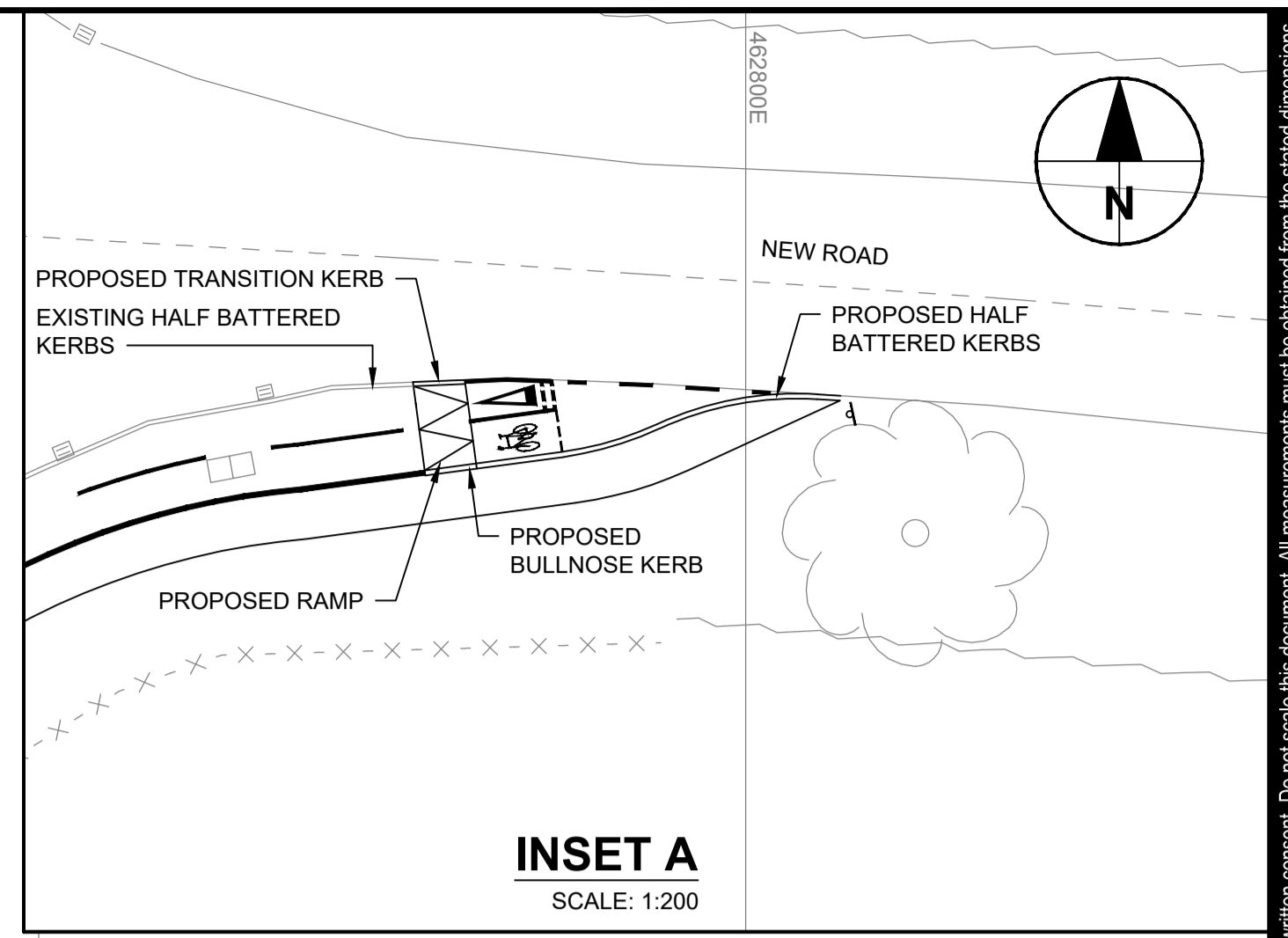
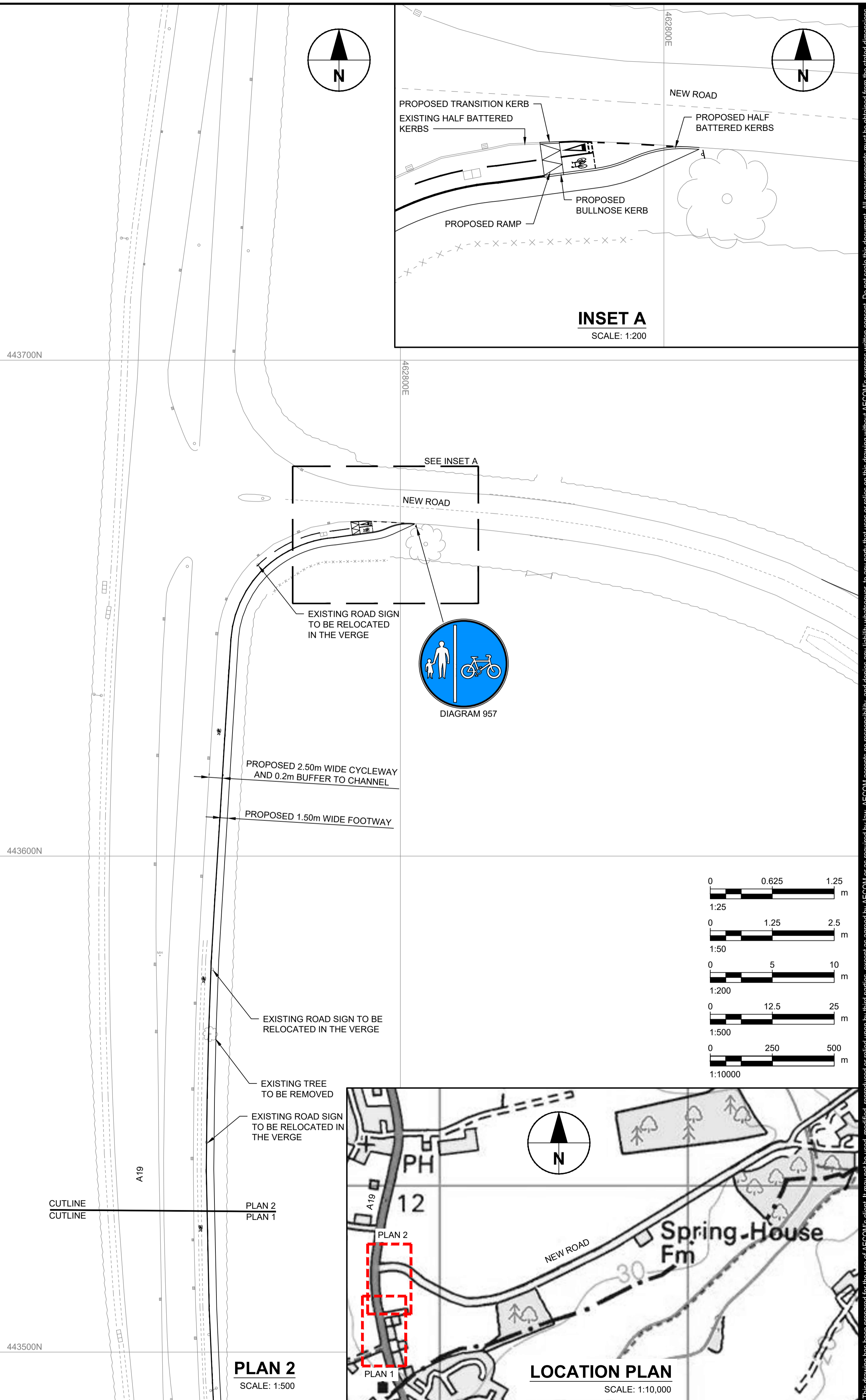

**INSET A**  
SCALE: 1:200

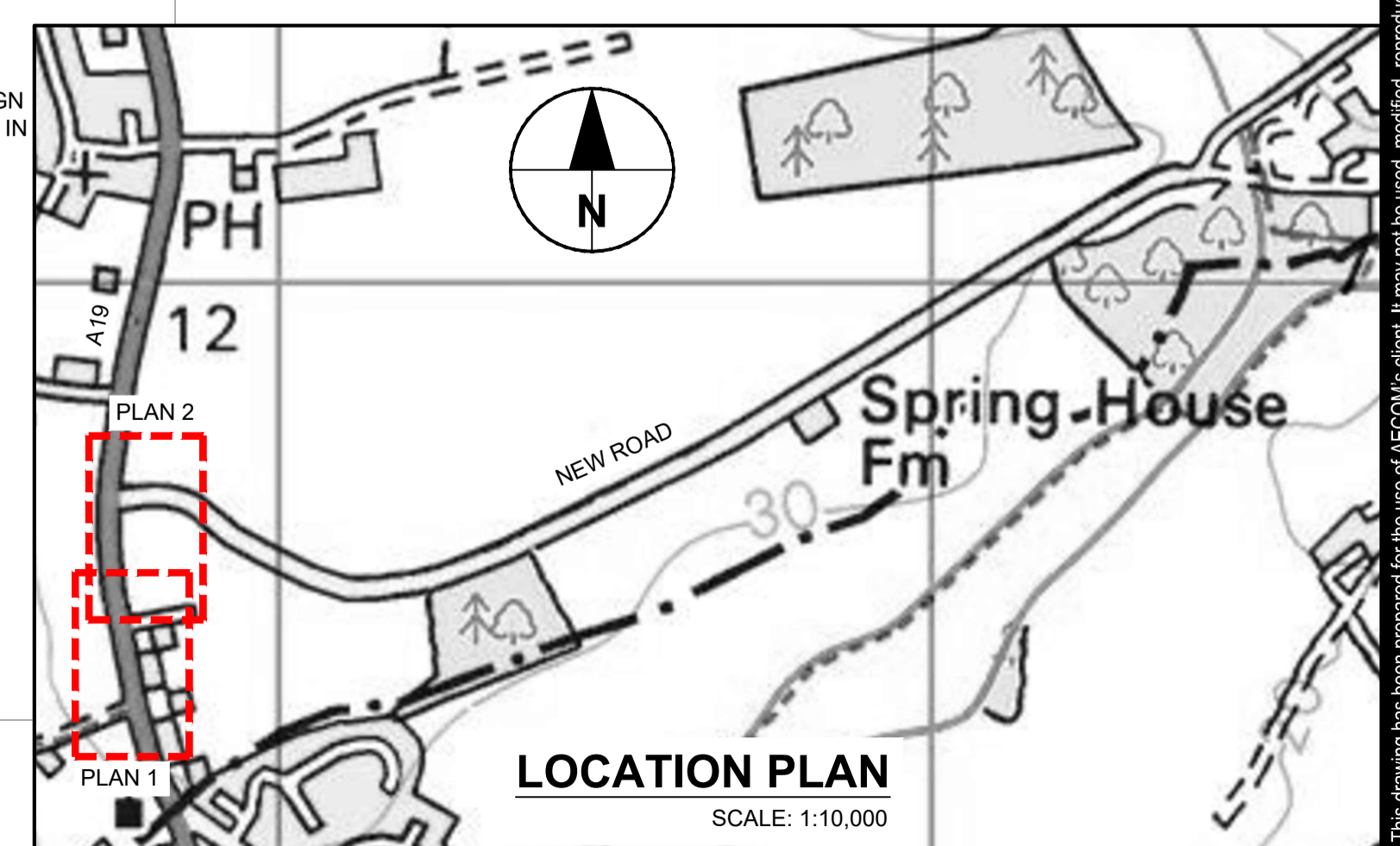
**PLAN 2**  
SCALE: 1:500

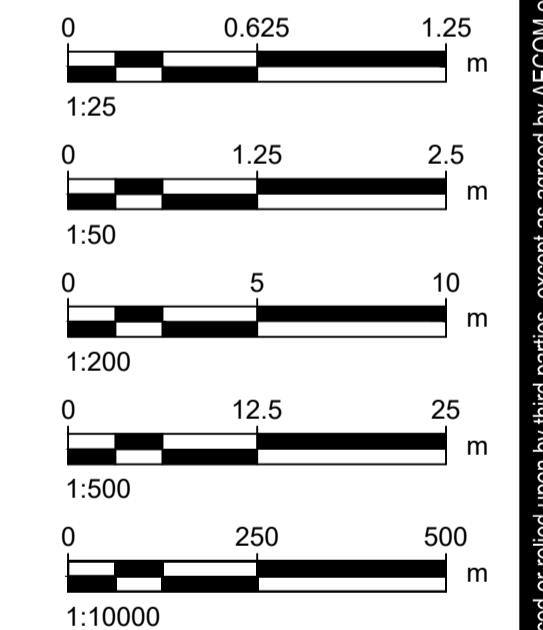

**LOCATION PLAN**  
SCALE: 1:10,000





**PROJECT**  
NORTH SELBY

**CLIENT**  
HEATONS

**CONSULTANT**  
AECOM  
Royal Court  
Basil Close  
Chesterfield  
S41 7SL  
T:+44-124-620-9221  
www.aecom.com

**NOTES**

- ALL DIMENSIONS ARE IN METRES AND ALL LEVELS ARE METRES ABOVE ORDNANCE DATUM UNLESS NOTED OTHERWISE.
- THIS DRAWING IS TO BE READ IN CONJUNCTION WITH ALL OTHER SCHEME DRAWINGS AND DOCUMENTS.
- THIS DRAWING IS TO BE USED FOR THE STATED PURPOSE OF ISSUE ONLY AND MUST NOT BE USED FOR ANY OTHER PURPOSE THAN THAT INDICATED.
- EXISTING LAYOUT BASED ON PEAK SURVEYING SERVICES TOPOGRAPHICAL SURVEY DATED MAY 2022.
- TACTILE PAVING TO BE IN ACCORDANCE WITH DEPARTMENT FOR TRANSPORT'S GUIDANCE ON THE USE OF TACTILE PAVING SURFACES.
- PROPOSED WIDTH OF 2.7m WHICH INCLUDES 2.5m WIDE CYCLEWAY AND A 0.2m ADDITIONAL WIDTH IN ACCORDANCE WITH LTN 1/20.

**KEY**

- PROPOSED TRAFFIC SIGN
- PROPOSED TACTILE PAVING - BLISTER (UNCONTROLLED CROSSING)
- PROPOSED TACTILE PAVING - TRAM AND LADDER

| ISSUE/REVISION                        |          |                   |    |    |    |    |
|---------------------------------------|----------|-------------------|----|----|----|----|
| P01                                   | 27-06-22 | CONCEPTUAL DESIGN | JB | KB | GH | DG |
| I/R                                   | DATE     | DESCRIPTION       | BY | CK | LV | AP |
| <b>SUITABILITY</b>                    |          |                   |    |    |    |    |
| S4 - Suitable for stage approval      |          |                   |    |    |    |    |
| <b>PROJECT NUMBER</b>                 |          |                   |    |    |    |    |
| 60598627                              |          |                   |    |    |    |    |
| <b>SHEET TITLE</b>                    |          |                   |    |    |    |    |
| A19<br>HIGHWAY<br>GENERAL ARRANGEMENT |          |                   |    |    |    |    |
| <b>SHEET NUMBER</b>                   |          |                   |    |    |    |    |
| NSLB-ACM-XX-XX-DR-CE-010001           |          |                   |    |    |    |    |
| <b>SCALE</b>                          |          |                   |    |    |    |    |
| AS SHOWN                              |          |                   |    |    |    |    |
| <b>REVISION</b>                       |          |                   |    |    |    |    |
| P01                                   |          |                   |    |    |    |    |

This drawing has been prepared for the use of AECOM's client. It may not be used, modified, reproduced or relied upon by third parties, except as agreed by AECOM or as required by law. AECOM accepts no responsibility, and denies any liability, whatsoever, to any party that uses or relies on this drawing without AECOM's express written consent. All measurements must be obtained from the stated dimensions.