

PIPE PENETRATION THROUGH SLEEPER WALL

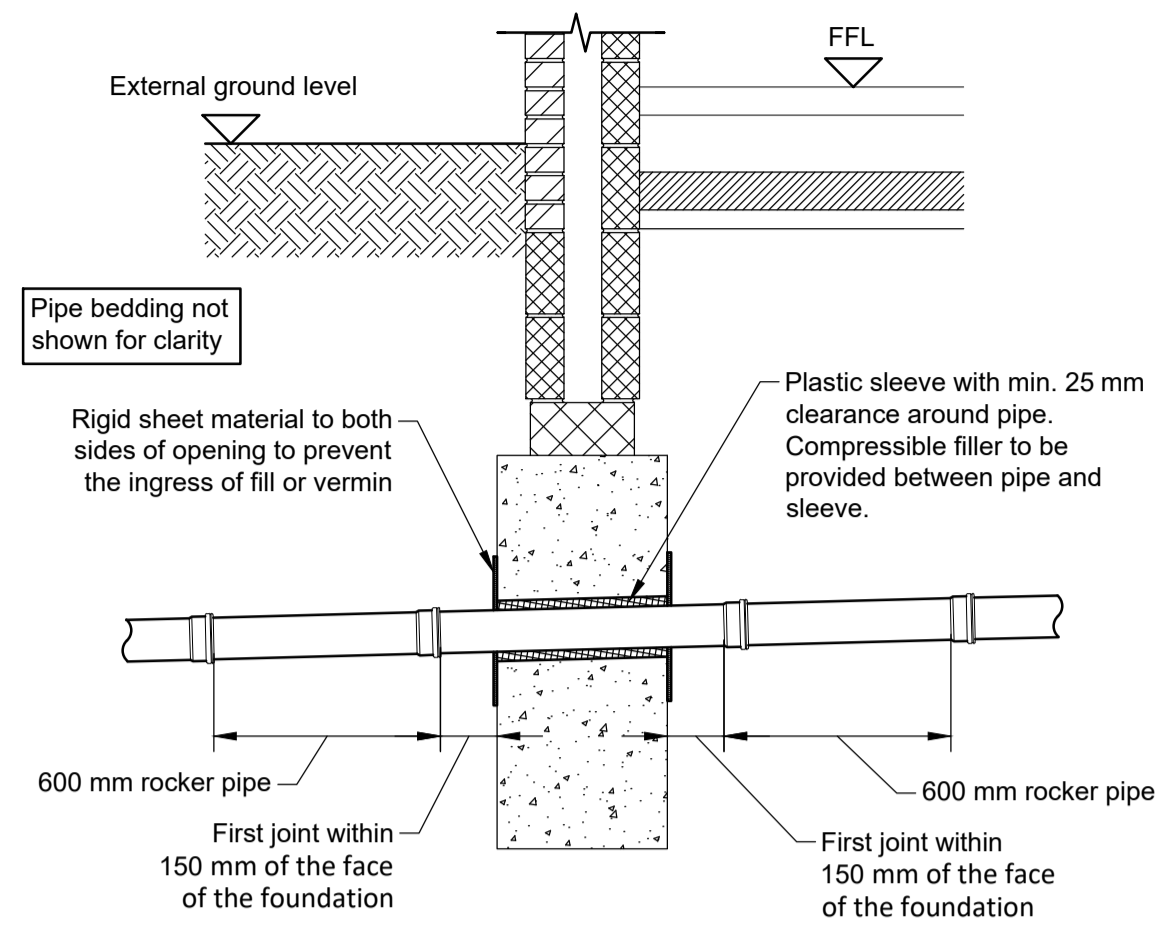

PIPE PENETRATION THROUGH STRIP FOOTING

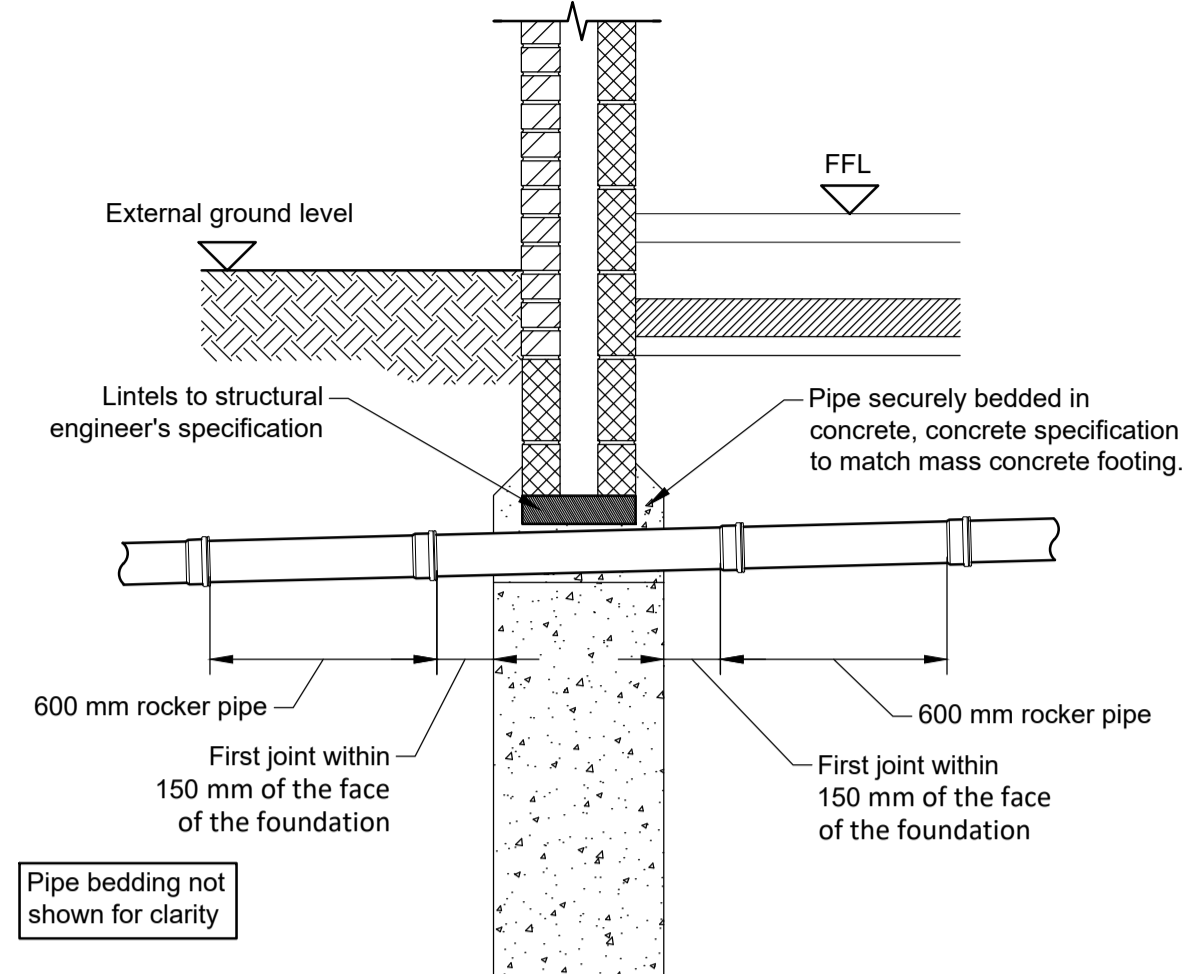

PIPE PENETRATION THROUGH SLEEPER WALL
Within 50 mm of top of foundation

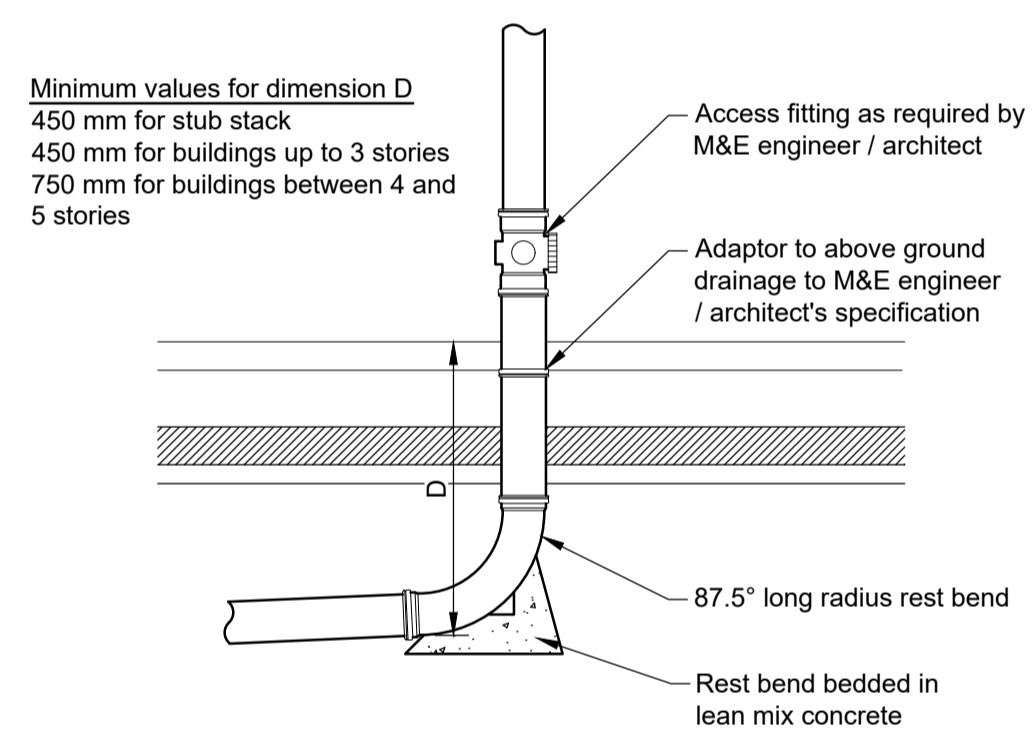

SOIL VENT PIPE OR STUB STACK TO DRAIN

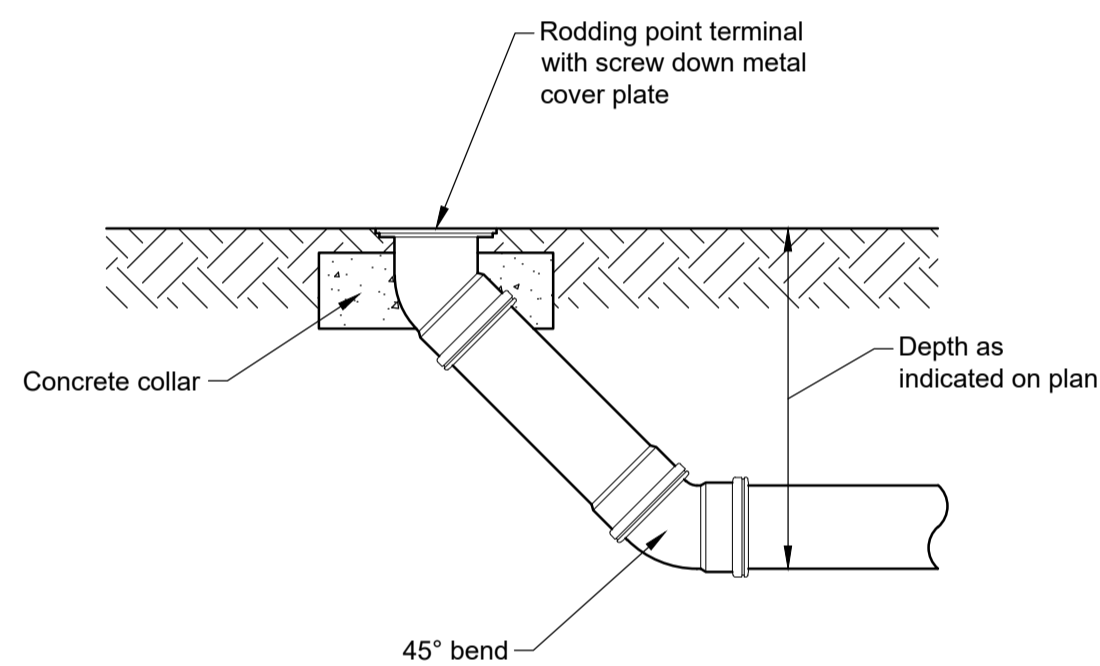

RODDING EYE

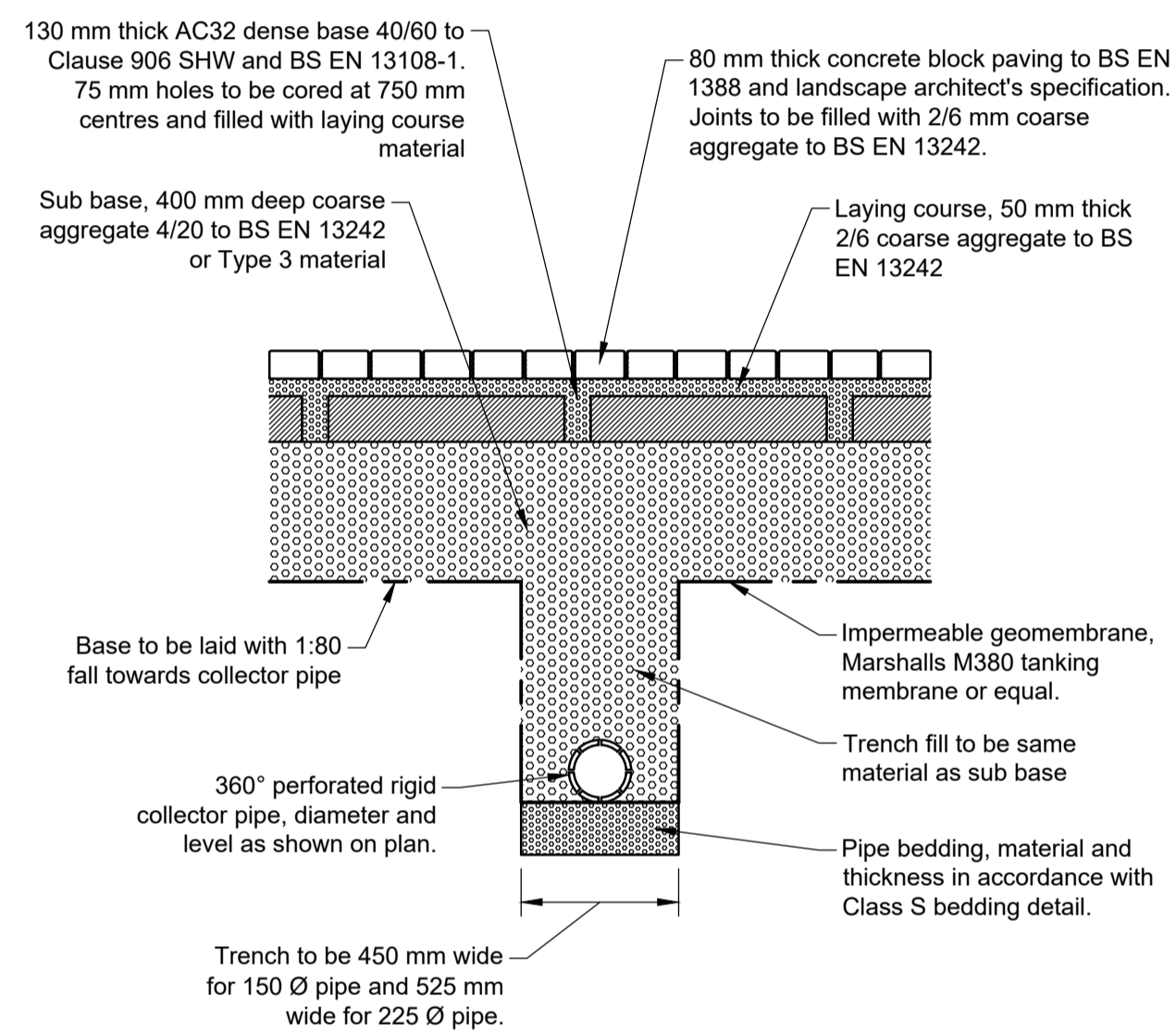

PERMEABLE PAVING WITH COLLECTOR DRAIN

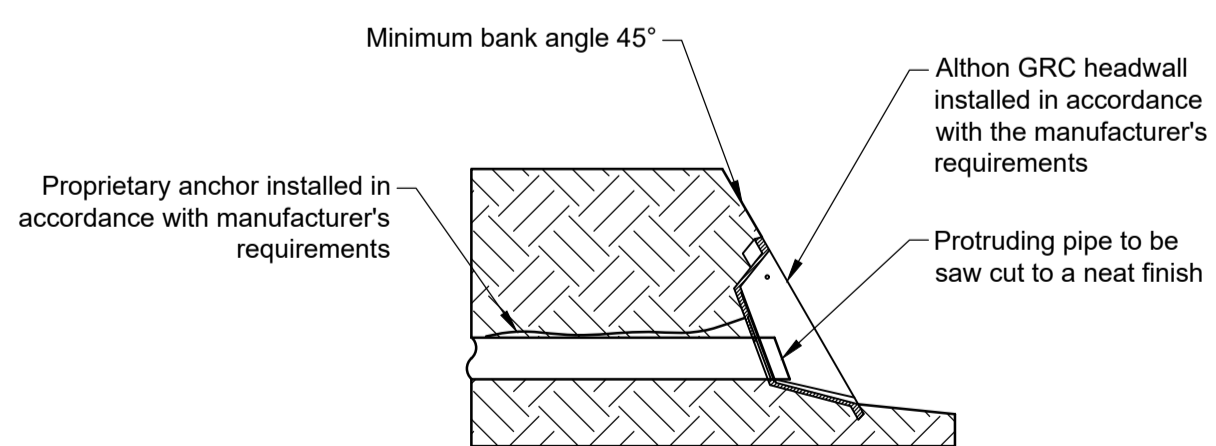

GRC HEADWALL

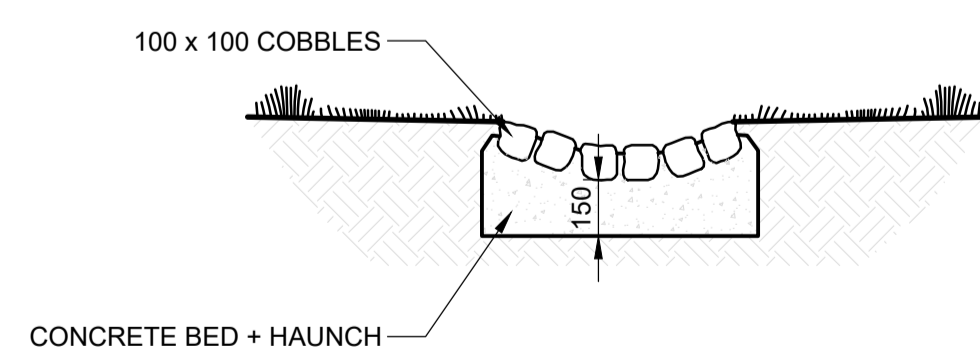

TYPICAL SECTION THROUGH RILL

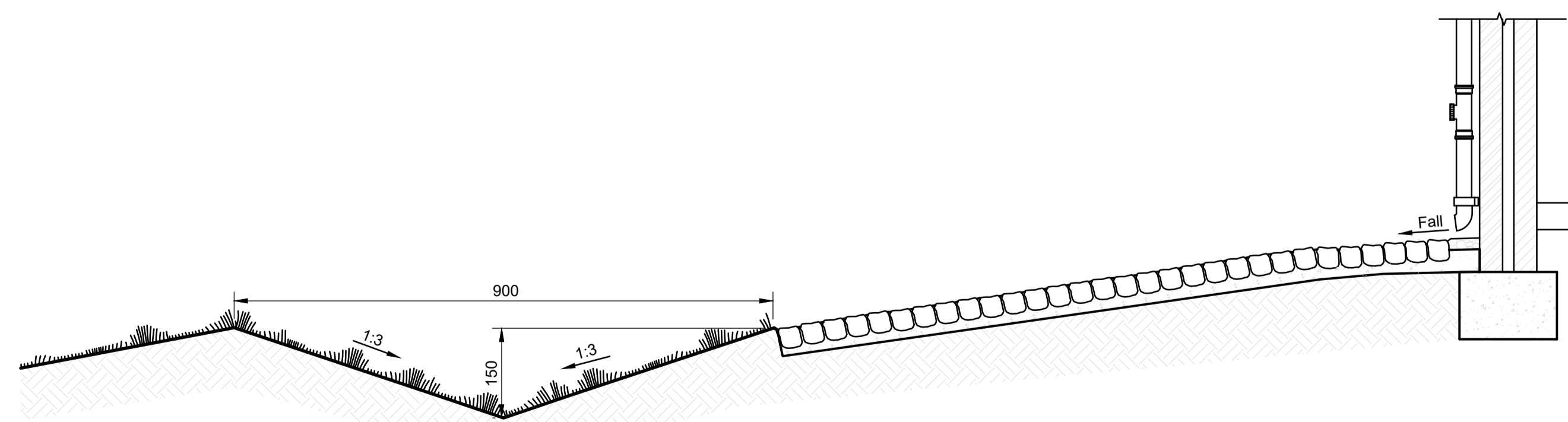

TYPICAL SECTION FROM BUILDING TO SWALE

DRAINAGE DETAIL NOTES

1. THIS DRAWING IS TO BE READ IN CONJUNCTION WITH ALL RELEVANT ARCHITECTS, ENGINEERS AND SPECIALIST DRAWINGS AND SPECIFICATIONS
2. DO NOT SCALE FROM THIS DRAWING IN EITHER PAPER OR DIGITAL FORM. USE WRITTEN DIMENSIONS ONLY.
3. CDM NOTE: ALL PIPEWORK, SILT TRAPS, CATCHPITS, TRAPPED GULLIES, ATTENUATION TANKS AND PUMP CHAMBERS TO BE REGULARLY INSPECTED EVERY THREE MONTHS AND CLEARED OUT ON A REGULAR FREQUENCY FOR THE FIRST NINE MONTHS. AFTER THIS PERIOD THE FREQUENCY CAN BE REDUCED TO EVERY SIX MONTHS. PUMP SETS TO BE INSPECTED AND MAINTAINED IN ACCORDANCE WITH THE RECOMMENDATIONS OF THE MANUFACTURER/PUMP PROVIDER. POROUS SURFACE TO BE REGULARLY SWEEPED THREE TIMES A YEAR TO REMOVE THE SILT. GREASE TRAPS/INTERCEPTORS ARE TO BE INSTECTED/EMPTIED AT LEAST ONCE A MONTH AND, PREFERABLY, EVERY TWO WEEKS.
4. HEALTH AND SAFETY: THE WORKS SHALL BE CARRIED OUT BY SPECIALIST COMPETENT AND EXPERIENCED CONTRACTORS WHO ARE MEMBERS OF A RECOGNISED NATIONAL ORGANISATION OPERATIVES SHALL HAVE RECEIVED FULL AND APPROPRIATE TRAINING FOR THE OPERATIONS THEY ARE TO UNDERTAKE. ALL WORK SHALL BE CARRIED OUT IN ACCORDANCE WITH ALL PERTINENT HEALTH AND SAFETY REGULATIONS.
5. REFER TO THE MANUFACTURER'S INSTALLATION GUIDANCE FOR ALL SPECIFIED PRODUCTS.

NOT FOR CONSTRUCTION

P01 23.05.23	ISSUED FOR INFORMATION	CDP	ST	
Rev	Date	Description	Drawn	Check

conisbee Consulting Structural Engineers
Consulting Civil Engineers

London • Cambridge • Norwich
1-5 Offord St London N1 1DH
Telephone 020 7700 6666
www.conisbee.co.uk

Drawing Status
S2 - SUITABLE FOR INFORMATION

Project	Date	APR 2023
GREEN END FARM OVER ROAD, LONGSTANTON	Scale	AS SHOWN
	Drawn	CDP

Title	Engineer	ST
DRAINAGE DETAILS SHEET 2	Project No	210650

Drawing No	Revision
210650-CON-XX-00-DR-C-1301	P01