

**CONSTRUCTION OF TWO EXTERNAL WALLS ON EXISTING
PROPERTY FOOTPRINT FOR A STUDY**

Applicant: Mr. John Healy

Address: Crispins, Valley Road, Fawkham, Longfield, DA3 8NA

Contents

1. INTRODUCTION	3
2. CONTEXT	3
3. PROPOSAL	4
4. EXISTING PROPERTY	5
1:1250 Site Location: Crispins, Valley Road, Fawkham, Longfield, DA3 8NA	5
Existing Front Elevation	6
Existing Side Elevation – showing east facing veranda	6
5. PROPOSED PLANS & ELEVATIONS	7
Proposed area – existing footprint.....	7
Proposed floor plan.....	7
Plan 1:50	8
Front Elevation 1:50	8
Right Elevation 1:50	9
Back Elevation 1:50	9
6. CGI SKETCHES OF THE PROPOSAL	10
Proposed two external walls on the east facing veranda	10
Proposed design – same bricks and windows as the existing structure	10

1. INTRODUCTION

- 1.1 This statement is prepared in support of a lawful development certificate, submitted by Mr. John Healy, owner of Crispins, Valley Road, Fawkham, Longfield, DA3 8NA, seeking permission for the following development: Construction of two external walls on existing property footprint for a study.
- 1.2 The lawful development certificate application, via PlanningPortal.co.uk is accompanied by existing and proposed site plan along with an illustrative CGI sketches produced by the applicant.

2. CONTEXT

- 2.1 The application site is located on Valley Road approximately 100m north of Fawkham Primary School.
- 2.2 The existing building is a three-bedroom, detached bungalow.
- 2.3 The existing building has two verandas – both outdoor structures consisting of the roof being held up by a steel column, as a permanent support.
- 2.4 The area has a solid concrete base, which forms part of the existing foundation.
- 2.5 The verandas are not enclosed and open to the elements, therefore have no other use other than storage.
- 2.6 The existing external wall of the property, within the east facing veranda has a large single pane glass window, which is very energy inefficient, letting both warm air out and cold air in and is also a security concern, being on ground level.
- 2.7 The area within the east facing veranda is approximately 12 square meters

3. PROPOSAL

Proposing to utilise existing veranda floor area into a home study by enclosing the two open faces with two external walls. The area is currently used as a ground floor level veranda and the two external walls will be within the existing footprint and use the existing foundations and concrete floor of the veranda.

The current total floor area is approximately 12 square meters and the external walls will be constructed with the same brick as the existing exterior walls and the windows will be the same as the existing windows.

There will be no changes to the roof line or height. The external walls will be tied into the existing roof.

The development will not directly impact on any other nearby residential properties.

Further details;

- 3.1 300mm wide external walls to match the existing brick work in size and colour, including insulated cavity space.
- 3.2 To install two new, double-glazed windows, matching the existing windows – in both size and positioning as the existing windows.
- 3.3 An internal door would be formed on the existing back wall with the removal of the existing single pane window.

4. EXISTING PROPERTY

1:1250 Site Location: Crispins, Valley Road, Fawkham, Longfield, DA3 8NA



Existing Front Elevation



Existing Side Elevation – showing east facing veranda



5. PROPOSED PLANS & ELEVATIONS

Proposed area – existing footprint

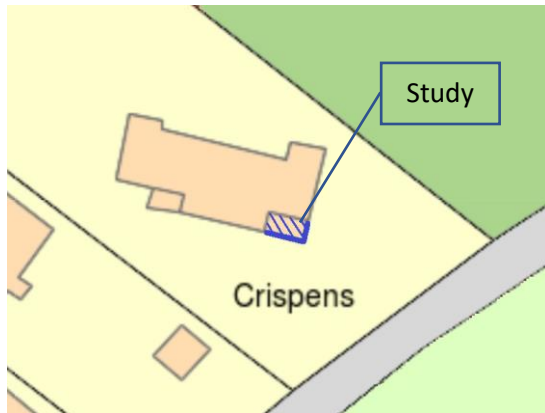

Proposed floor plan

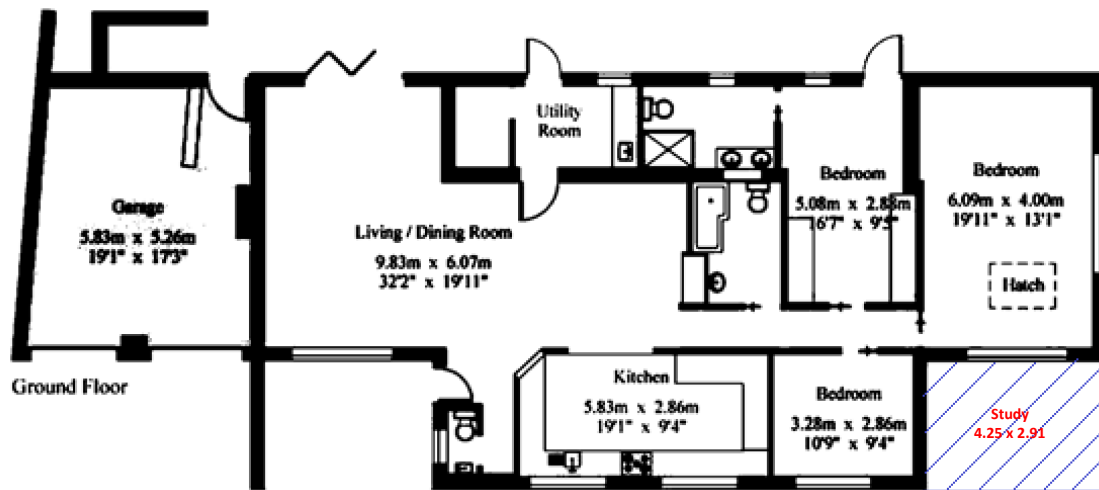

Plan 1:50

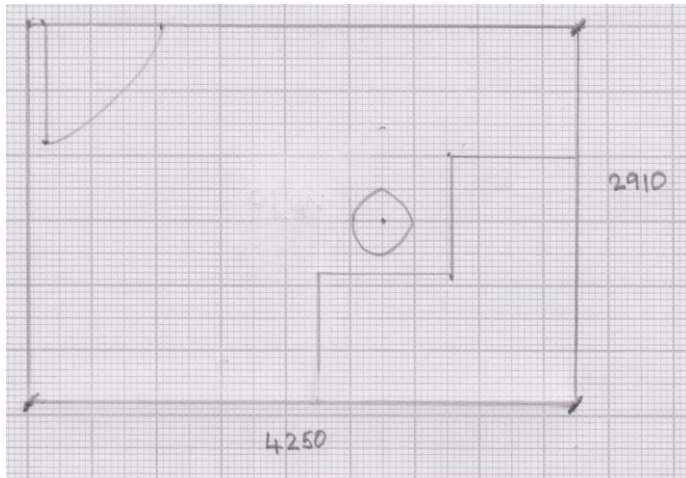

Front Elevation 1:50

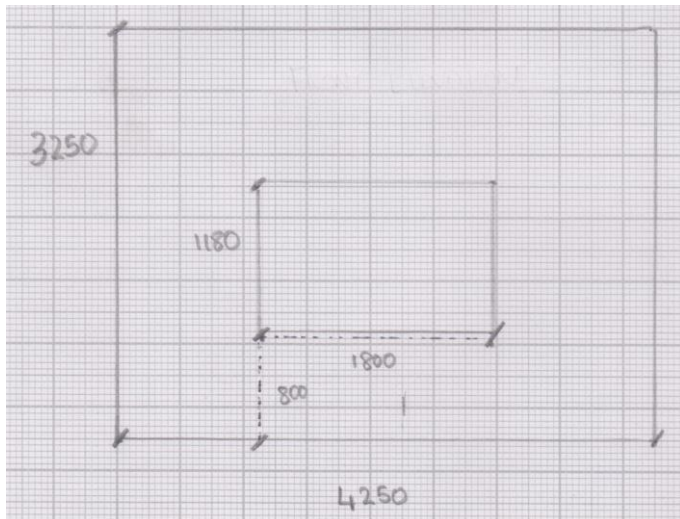

Right Elevation 1:50

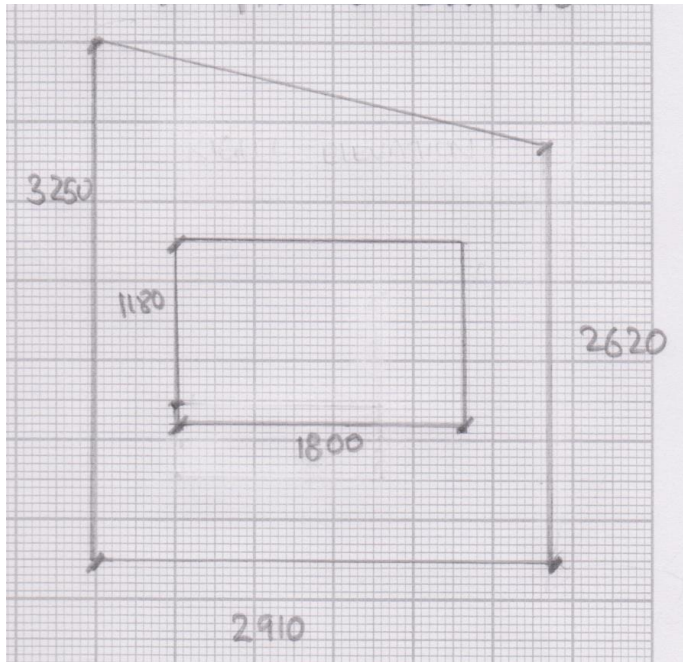

Back Elevation 1:50

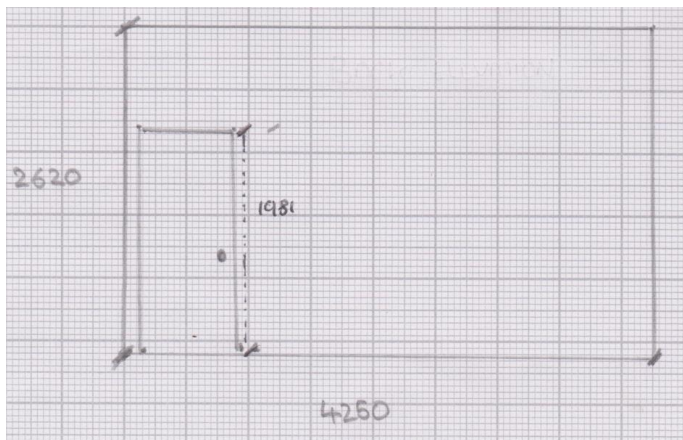

6. CGI SKETCHES OF THE PROPOSAL

Proposed two external walls on the east facing veranda



Proposed design – same bricks and windows as the existing structure

