

**JOINT DETAIL OF TYPE Z BEDDING**

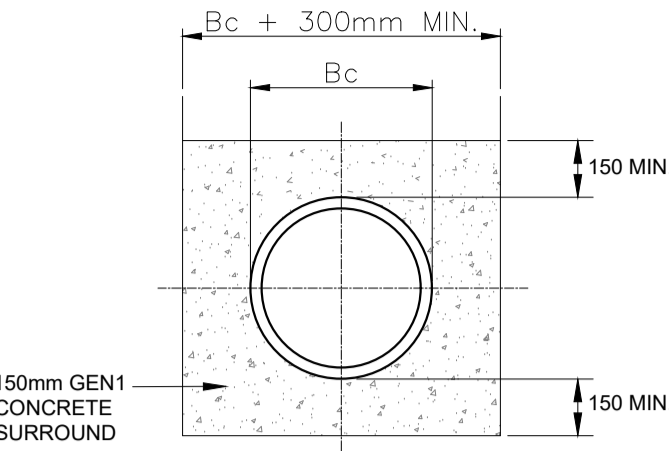

**TYPE S BEDDING**

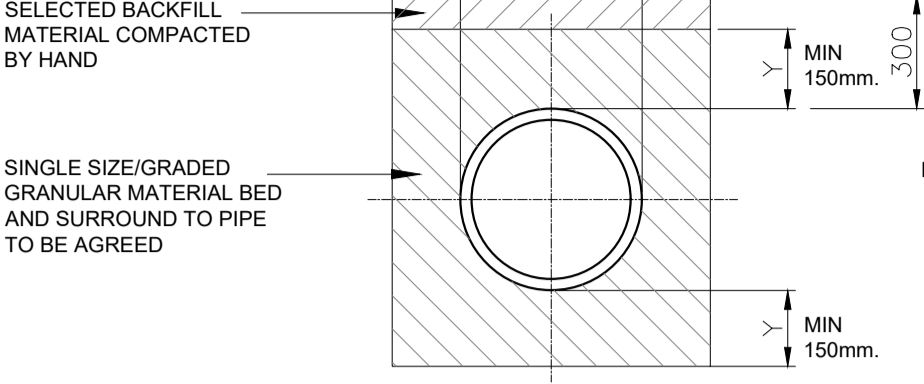

**SOIL PIPE AND ACCESS PIPE DETAIL**

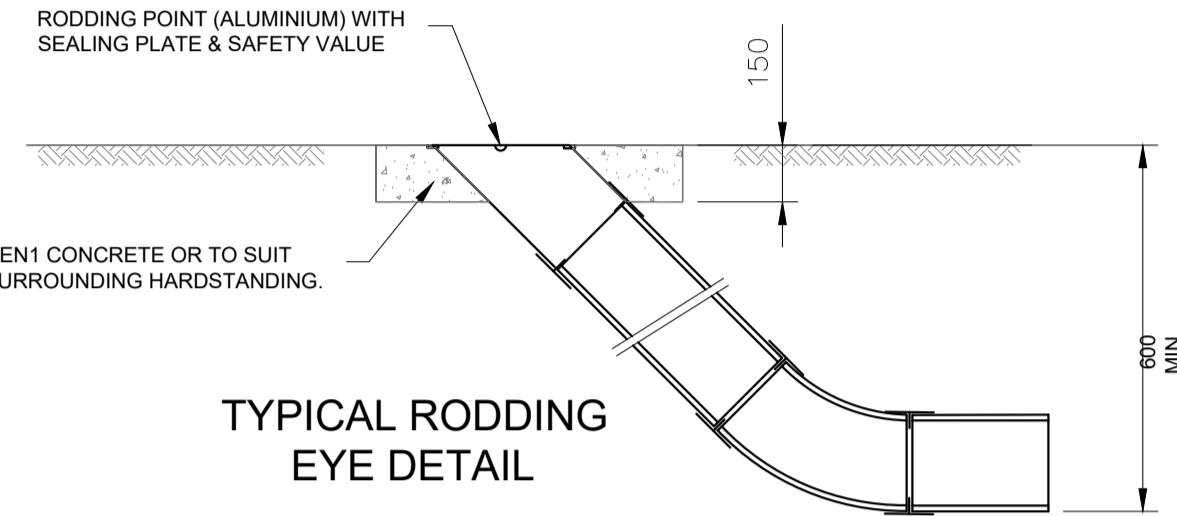

**TYPICAL RODDING EYE DETAIL**

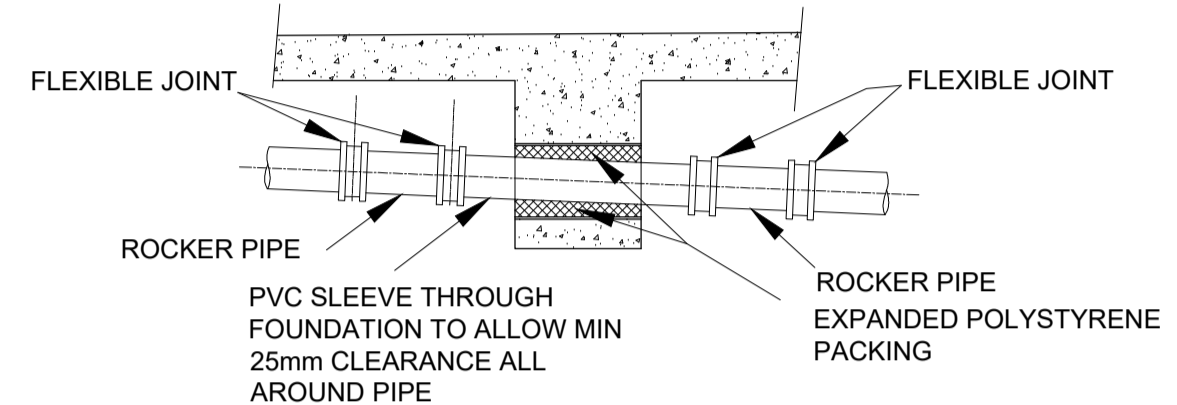

**PIPE PASSING THROUGH FOUNDATIONS**

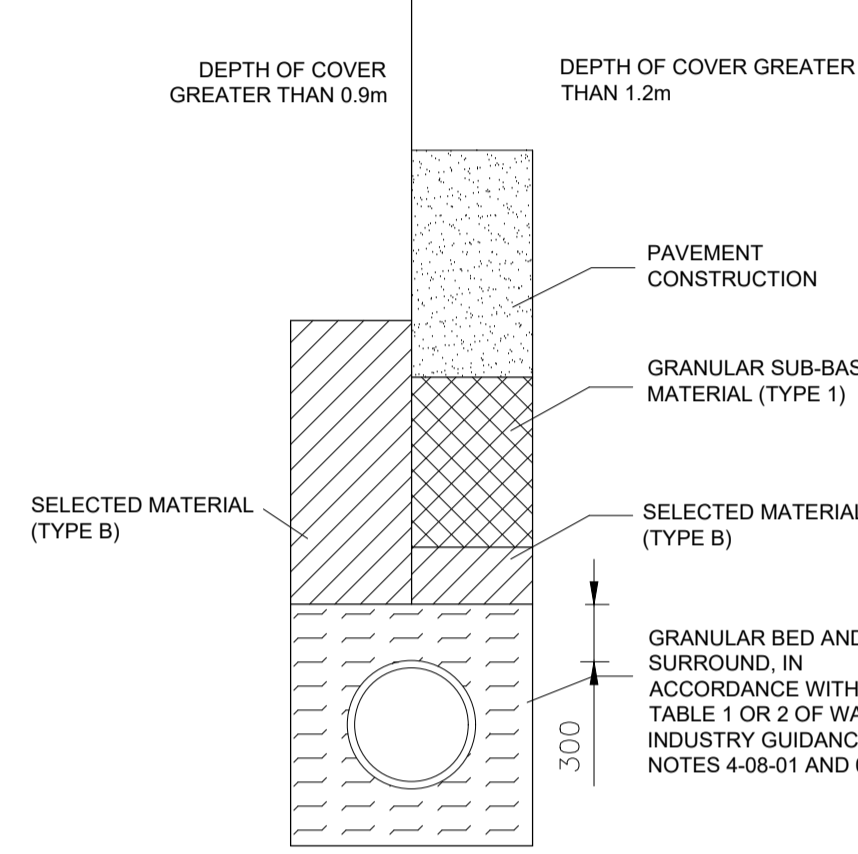

**PIPE SURROUND & TRENCH REINSTATEMENT**

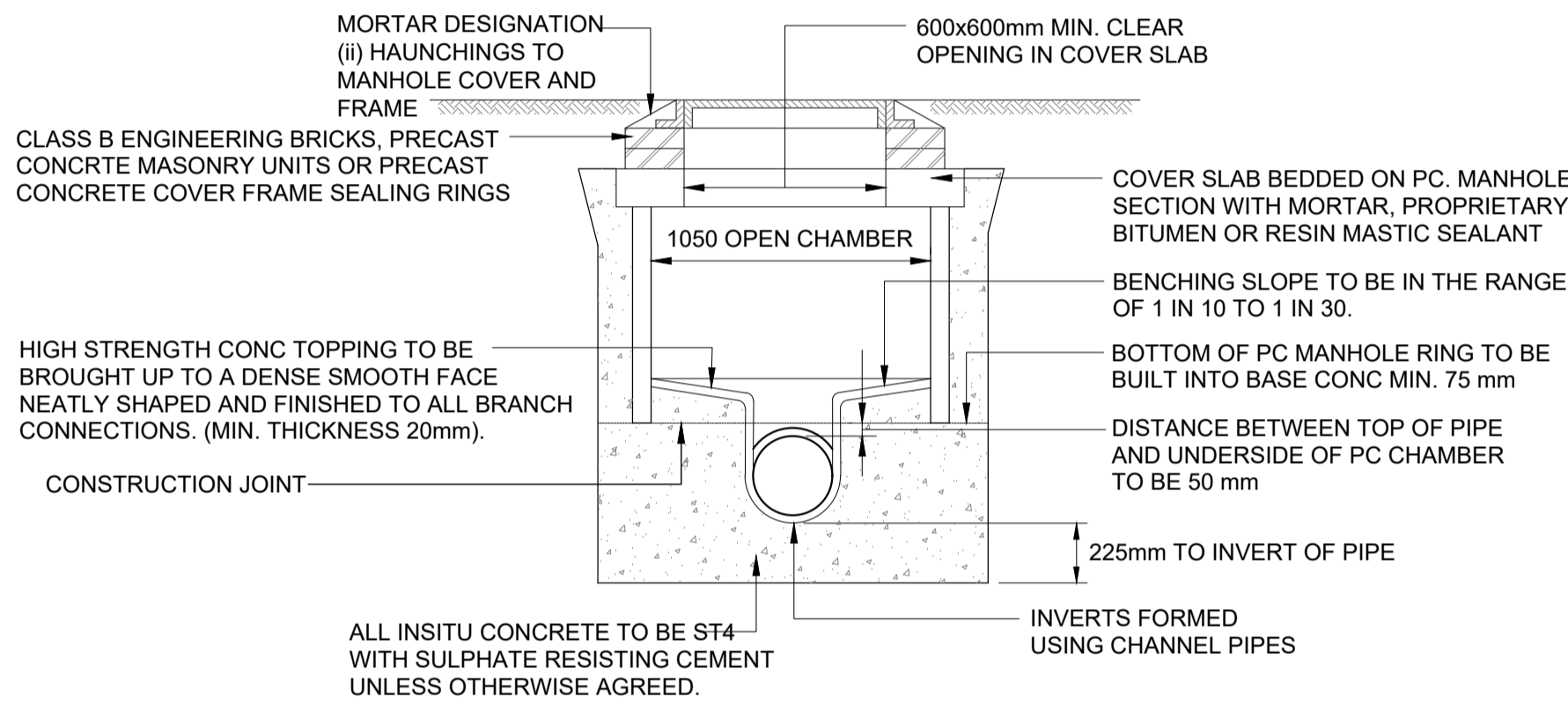

**MANHOLE TYPE F**  
DEPTH FROM GROUND TO SOFFIT LESS THAN 1m  
SCALE 1:25

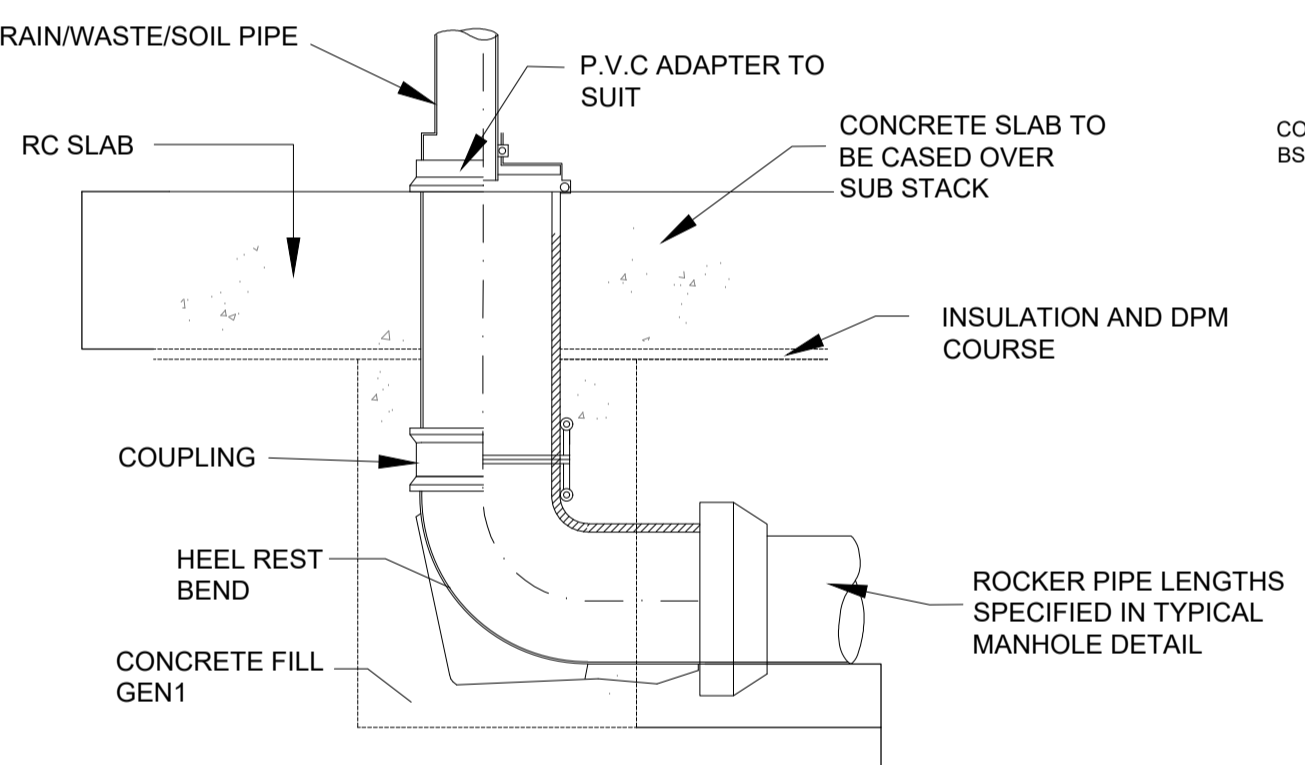

**INTERNAL GROUND SOCKET DETAIL**

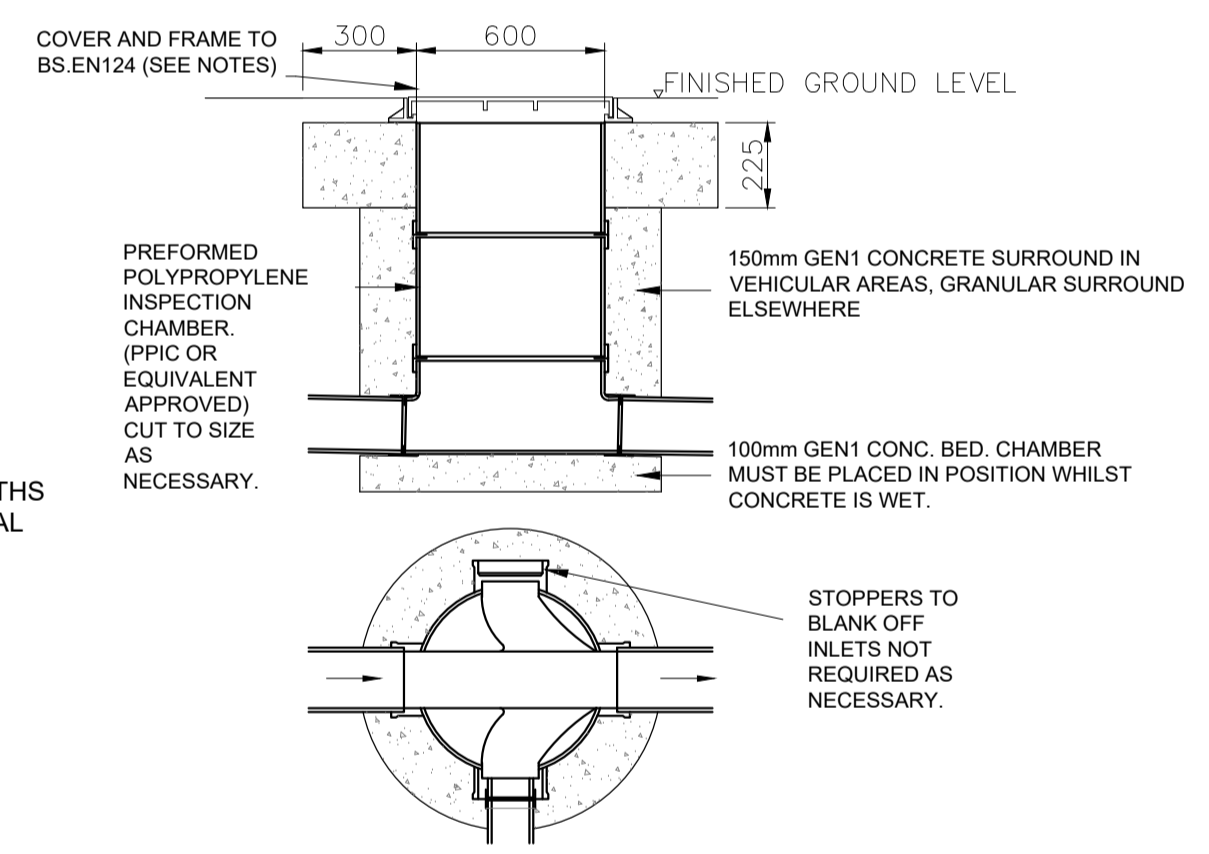

**POLYPROPYLENE INSPECTION CHAMBER**  
MAX DEPTH 1.2m

ROCKER PIPES	
NOMINAL DIAMETER (mm)	EFFECTIVE LENGTH (m)
150 TO 600	0.6
675 TO 750	1.0
825 AND OVER	1.25

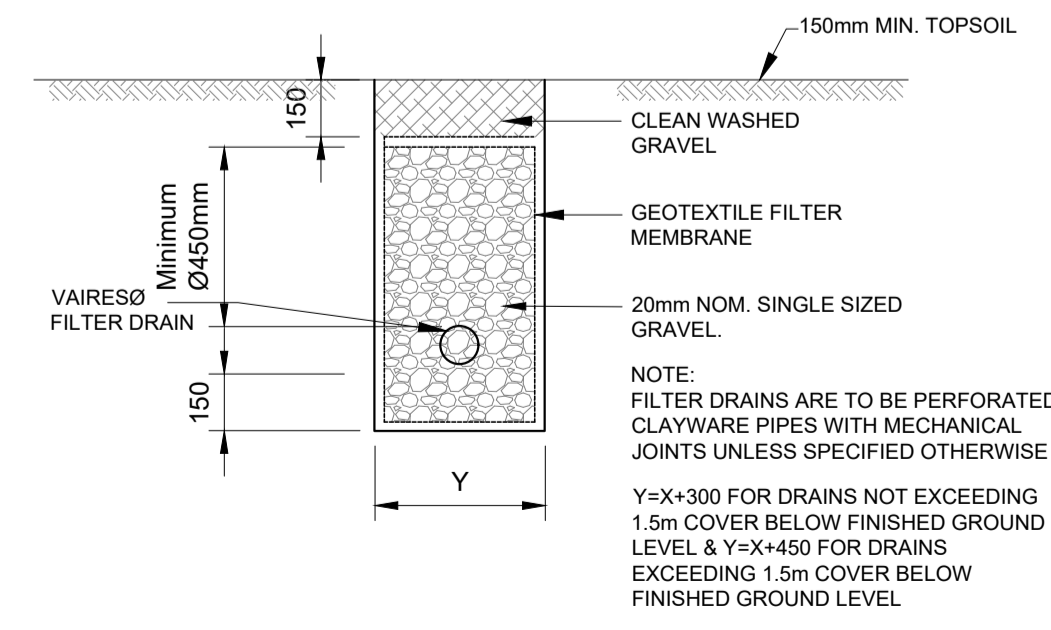
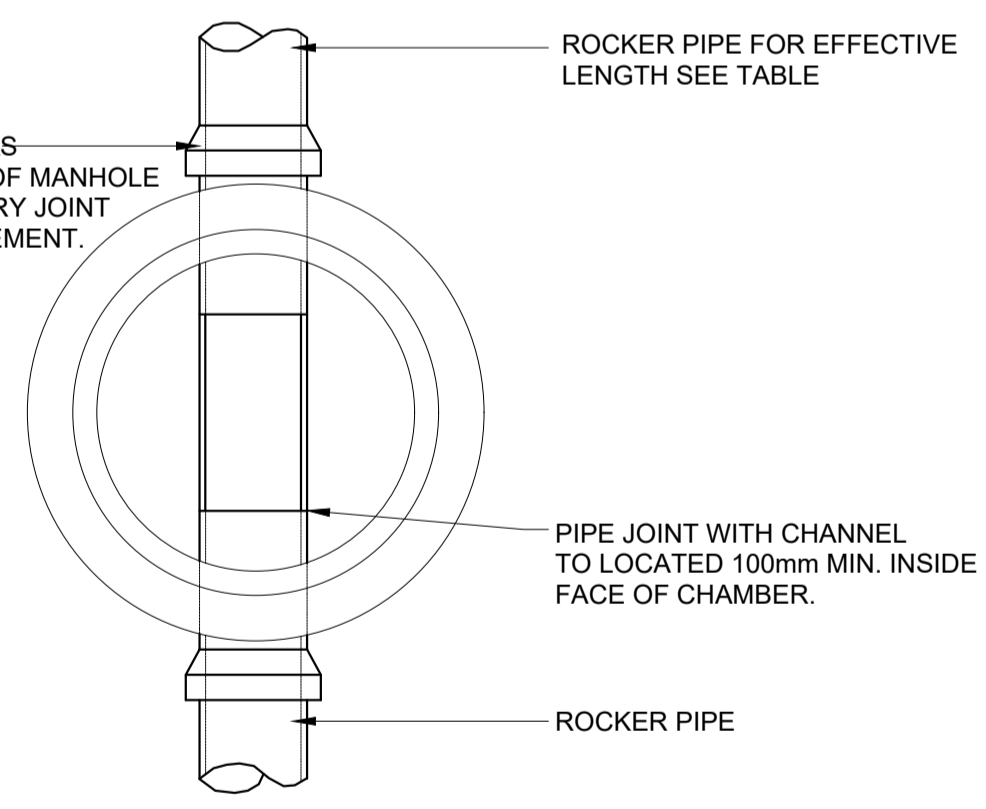

**LAND DRAIN**

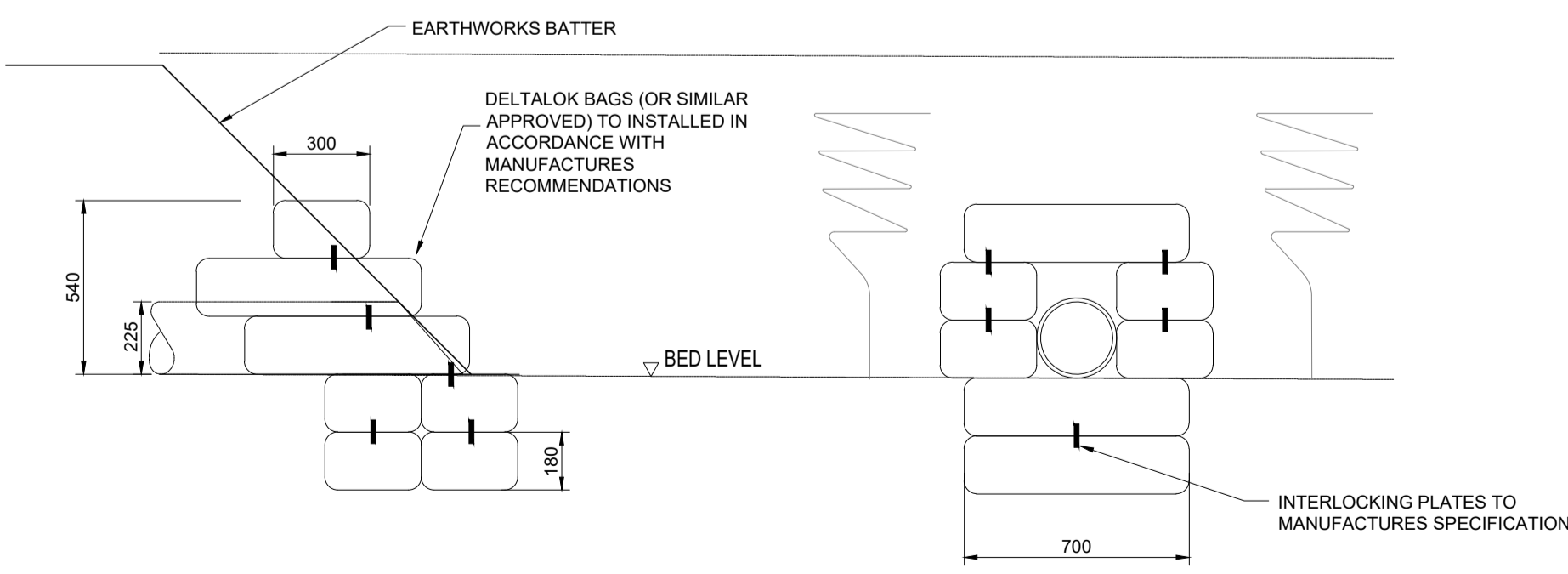

**BAG WORK HEADWALL DETAIL**  
1:20

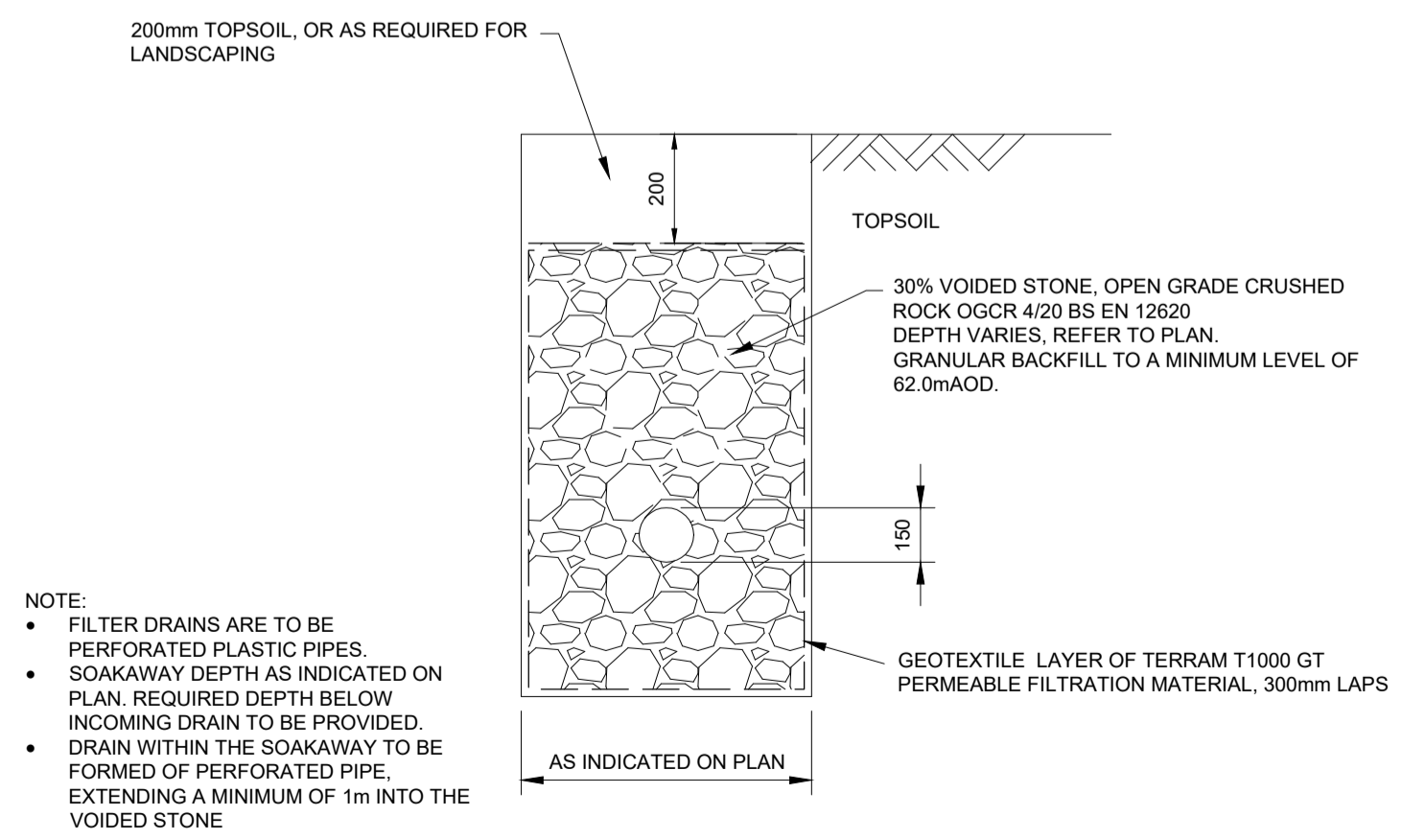

**SOAKAWAY**

**BEDDING NOTES**

1. GRANULAR PIPE BEDDING MATERIAL FOR PIPES, AND BACKFILLING FOR TEMPORARY DRAINS (TRENCH SUB-DRAINS), SHALL CONSIST OF AGGREGATES FROM NATURAL SOURCES OR SINTERED PULVERIZED-FUEL ASH COMPLYING WITH THE RELEVANT PROVISIONS OF BS 882 AND BS 3797, PART 2 RESPECTIVELY, SIZED IN ACCORDANCE WITH THE FOLLOWING TABLE.

NOMINAL BORE	ALTERNATIVE AGGREGATE SIZES (mm)	
	SINGLE-SIZED	GRADED
100	10	-
150	10 OR 14	14 TO 5
225 - 300	10, 14 OR 20	14 TO 5 OR 20 TO 5
375 - 525	14 TO 20	14 TO 5 OR 20 TO 5
EXCEEDING	14, 20 OR 40	14 TO 5, 20 TO 5 OR 40 TO 5

2. SELECTED BACKFILL MATERIAL, WHETHER SELECTED FROM LOCALLY EXCAVATED MATERIAL OR IMPORTED, SHALL CONSIST OF UNIFORM, READILY COMPACTABLE MATERIAL, FREE FROM VEGETABLE MATTER, BUILDING RUBBISH AND FROZEN MATERIAL, OR MATERIALS SUSCEPTIBLE TO SPONTANEOUS COMBUSTION, AND EXCLUDING CLAY OF LIQUID LIMIT GREATER THAN 80 AND/OR PLASTIC LIMIT GREATER THAN 55, AND MATERIALS OF EXCESSIVELY HIGH MOISTURE CONTENT. CLAY LUMPS AND STONES SHALL BE RETAINED ON 75mm AND 37.5mm SIEVES RESPECTIVELY.

NOMINAL BORE OF PIPE (MM)	THICKNESS OF COMPRESSIBLE FILLER (MM)
LESS THAN 450	18
450 - 1200	36
EXCEEDING 1200	54

3. COMPRESSIBLE FILLER FOR INTERRUPTING CONCRETE PROTECTION TO PIPELINES SHALL CONSIST OF BITUMEN IMPREGNATED INSULATING BOARD TO BS 1142, PART 3 OR OTHER EQUALLY COMPRESSIBLE MATERIAL. THE THICKNESS OF COMPRESSIBLE FILLER SHALL BE AS FOLLOWS:

4. THE CONTRACTOR IS TO PROTECT BURIED PIPES (PARTICULARLY SHALLOW PIPES) FROM DAMAGE CAUSED BY LOADS IMPOSED BY CONSTRUCTION PLANT.

5. BELOW ROADS AND OTHER PAVED AREAS TRENCHES SHALL BE BACKFILLED WITH DOT SPECIFICATION TYPE 1 SUB-BASE MATERIAL UP TO ROAD/PAVING FORMATION LEVEL. ALL OTHER TRENCHES UNLESS OTHERWISE SPECIFIED SHALL BE BACKFILLED TO FINISHED GROUND LEVEL OR UNDERSIDE OF TOPSOIL LAYER WITH WELL COMPACTED EXCAVATED MATERIAL.

**CONCRETE BEDDINGS**

- THE USE OF GRANULAR BEDDINGS BELOW CONCRETE BEDDINGS (BEDDING TYPES A2, A4, A6) ARE FOR USE IN WET CONDITIONS.
- CONCRETE CRADLES MAY EXTEND TO SIDES OF TRENCH.
- TRANSVERSE STEEL TO BE 0.4% MIN OF CONCRETE AT X-X (FM=3-4) UNLESS OTHERWISE STATED.
- BEDDING BENEATH & AT SIDES OF PIPE TO BE WELL COMPACTED.
- BEDDING/BACKFILL DIRECTLY ABOVE PIPE TO BE LIGHTLY COMPACTED BY HAND. DIMENSION Y: 1/6 BC OR 100MM UNDER BARRELS, AND 50mm UNDER SOCKETS WHICHEVER IS GREATER (SUBJECT TO 400MM MAX.).
- DN = NOMINAL BORE OF PIPE.
- BC = EXTERNAL DIAMETER OF PIPE BARREL.

**TRENCH WIDTH**

1. THE MAXIMUM TRENCH WIDTHS ARE TO BE AS SHOWN BELOW UNLESS THE APPROVAL OF THE ENGINEER IS OBTAINED.

INTERNAL PIPE DIAMETER	MAXIMUM TRENCH WIDTH
100	600
150	600
225	700
300	850
375	1050
450	1150
525	1200
600	1350
675	1450
750	1500
825	1600
900	1900
975	2000
1050	2100
1200	2300

**NOTE:**

- FILTER DRAINS ARE TO BE PERFORATED PLASTIC PIPES.
- SOAKAWAY DEPTH AS INDICATED ON PLAN. REQUIRED DEPTH BELOW INCOMING DRAIN TO BE PROVIDED.
- DRAIN WITHIN THE SOAKAWAY TO BE FORMED OF PERFORATED PIPE, EXTENDING A MINIMUM OF 1m INTO THE VOIDED STONE.

**NOTES**

- This drawing is to be read in conjunction with all relevant architects', engineers', and specialist's drawings, bills of quantities and specifications.
- Do not scale off this drawing.
- All dimensions are to be confirmed on site by the contractor.
- Refer to MHA drawing 130 for all general notes.

Rev.	Date	Made by	Amendments
P02	08.09.23	FJ	ADDITIONAL DRAINAGE DETAILS ADDED.
P01	10.06.22	CH	ISSUED FOR PLANNING

**PLANNING**

**MHA STRUCTURAL DESIGN**  
London +44 (0)207 375 6340  
Cambridge +44 (0)1223 776340  
mhastructuraldesign.com

Job Title  
**BEECHES FARM, TRING**

**PROPOSED DRAINAGE CONSTRUCTION DETAILS SHEET 1 OF 2**

Scales			
1:200 @ A1			
Drawn	CH	Date	10.06.22
Job No	21026	Drawing No	511
Checked		Revision	P02