

---

**Post Occupancy Waste Management Plan**

16/09/2022

Sladacre Barn, Bath Road, Blagdon, Bristol

**Introduction**

This document has been prepared by Western Building Consultants Ltd to discharge condition 11 in regards to application 21/P/2715/FUL.

This post occupancy waste plan has been used to identify the method of waste management and to benchmark the development against the council's standards.

**Access**

The site must allow for adequate access for a Refuse Collection Vehicle of dimensions 3.8m high x 10m length x 2.5m width, Bath Road is currently serviced by Refuse Collection Vehicles which collect via the highway, this document will provide the information required for discharge.



*Image courtesy of Google Maps*

## Waste & Recycling Provision

- The plan has storage space for waste located externally from the building, designed to house sufficient facilities for a new dwelling that is positioned to reduce any impact on the local vistas. It is constructed with timber cladding to give a soft vernacular in keeping with the project.
- There is a short distance from the external storage to the bin presentation area for collection via the shows collection point that allows for the 10x2.5m spacing.
- The bins are will be put on the highway on day of collection and then returned to external storage when they have been collected.



Fig 1 – Showing Bin presentation area & Vehicle collection point

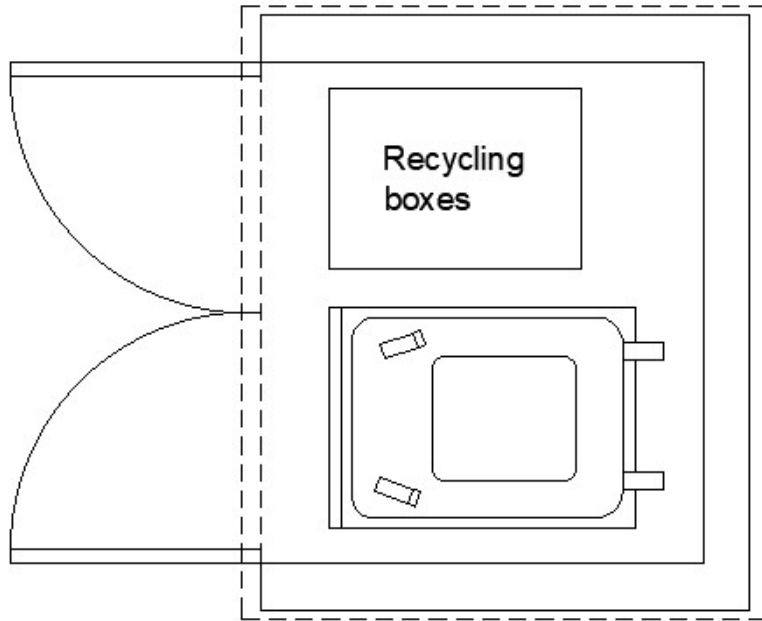

180 Litre Wheelie Bin, (W) 485mm,  
(D) 712mm, (H) 1063mm

Fig 2 – Showing storage space for waste

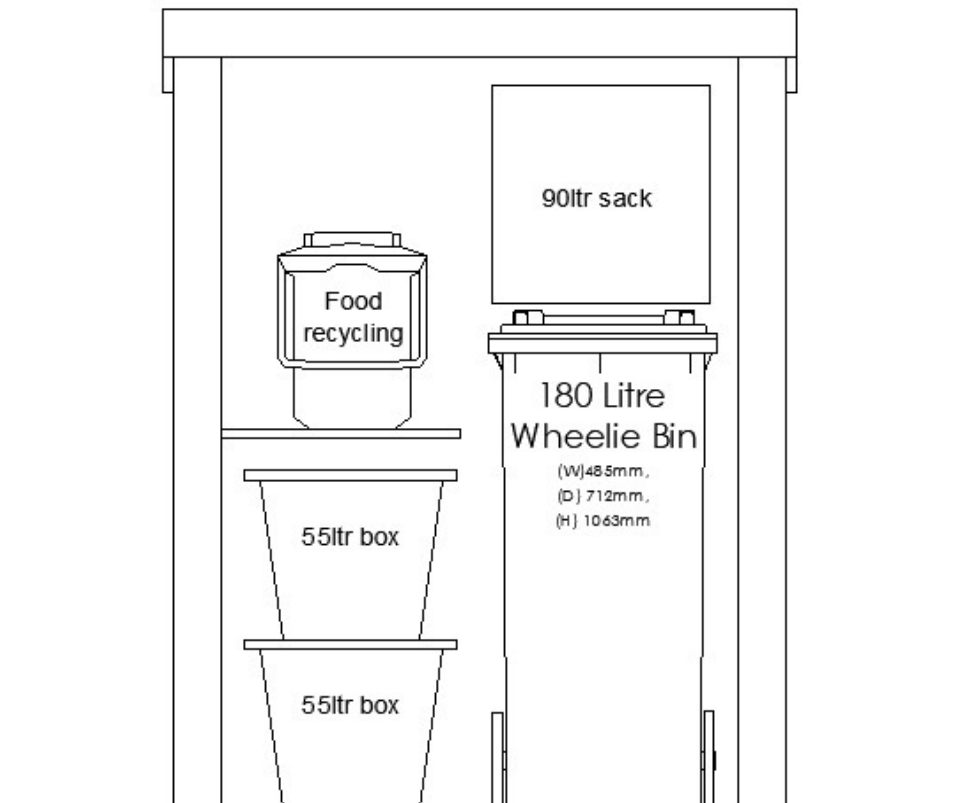

Fig 3 – Showing elevation of storage space for waste