

TYPICAL PROJECTED BAY WINDOW

2

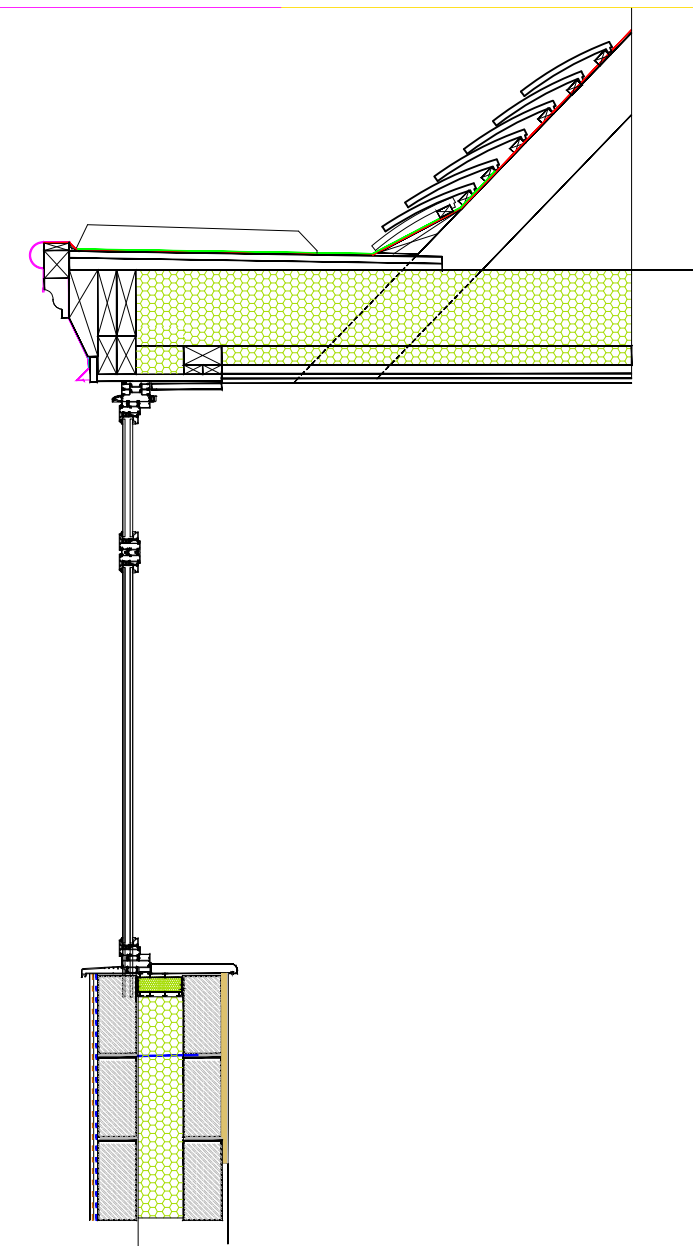

TYPICAL SECTION 2-2 OF PROJECTED BAY WINDOW

REVISION					
DATE	REV.	DESCRIPTION	DRAWN BY	CHKD	AUTH.

THE ARCHITECT SHALL OWN THE COPYRIGHT IN THE ORIGINAL WORK PRODUCED IN THE PERFORMANCE OF THE SERVICES AND GENERALLY ASSERTS THE ARCHITECT'S MORAL RIGHTS TO BE IDENTIFIED AS THE AUTHOR OF THIS WORK. NO PART OF ANY DESIGN BY THE ARCHITECT MAY BE REPRODUCED OR TRANSMITTED IN ANY FORM OR BY ANY MEANS, ELECTRONIC OR MECHANICAL, INCLUDING PHOTOCOPYING, RECORDING, OR BY ANY INFORMATION STORAGE AND RETRIEVAL SYSTEM, WITHOUT THE WRITTEN CONSENT OF THE ARCHITECT. THE ARCHITECT'S DESIGN AND DRAWINGS ARE THE PROPERTY OF THE ARCHITECT AND ARE NOT TO BE REPRODUCED, COPIED, OR TRANSMITTED IN ANY FORM OR BY ANY MEANS, ELECTRONIC OR MECHANICAL, INCLUDING PHOTOCOPYING, RECORDING, OR BY ANY INFORMATION STORAGE AND RETRIEVAL SYSTEM, WITHOUT THE WRITTEN CONSENT OF THE ARCHITECT. THE ARCHITECT SHALL NOT BE LIABLE IF THE DRAWING IS MODIFIED OR OTHERWISE USED FOR ANY PURPOSE OTHER THAN THAT FOR WHICH IT WAS PREPARED. IF AT ANY TIME THE CLIENT IS IN DEFAULT OF PAYMENT OF ANY FEES OR OTHER AMOUNTS PROPERLY DUE, THE ARCHITECT MAY SUSPEND FURTHER USE OF THE LICENSE ON GIVING 7 DAYS' NOTICE OF THE INTENTION OF DOING SO. NO DIMENSIONS TO BE SCALED FROM THIS DRAWING. THE ARCHITECT MUST BE INFORMED OF ANY DISCREPANCY ON THE DRAWINGS.

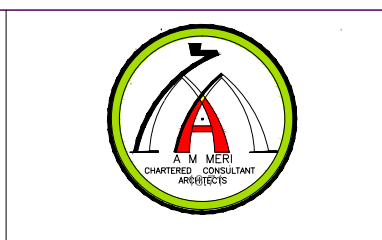
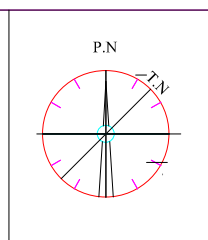

CLIENT ADDRESS		CLIENT NAME:		AUTHORIZED BY		DATE	
Mr Nagi HOMWOOD FARM LANE LOUDWATER		Mr Nagi		Mr Nagi		DEC 2018	
SITE ADDRESS		DRAWING TITLE:		LOCATION		DRAWING STATUS	
Mr Nagi HOMWOOD FARM LANE LOUDWATER		LAYOUTS		THREE RIVERS		PROPOSAL	
PROJECT NUMBER	PROJECT STAGE	DISCIPLINE	DRAWING NUMBER	DRAWING SHEETS	DRAWING REVISION	SCALE	
1025	PROP.	AR	024	A1	-	A1- 1:10 A3- 1:20	

EXTENSION	DESIGNED BY:	DATE
	A.M.MERI	JAN 2018