

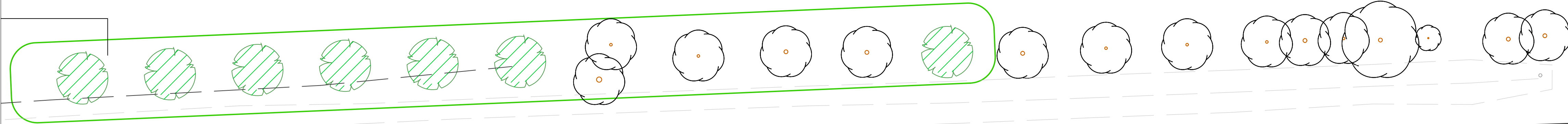

**SYCAMORE TREE PLANTING
ALONG FIELD EDGE TO
SCREEN GRAIN STORE**
7 No Acer Pseudoplatanus
2.5-5M tall,
Trunk girth: 10-12 cm
Bare Root

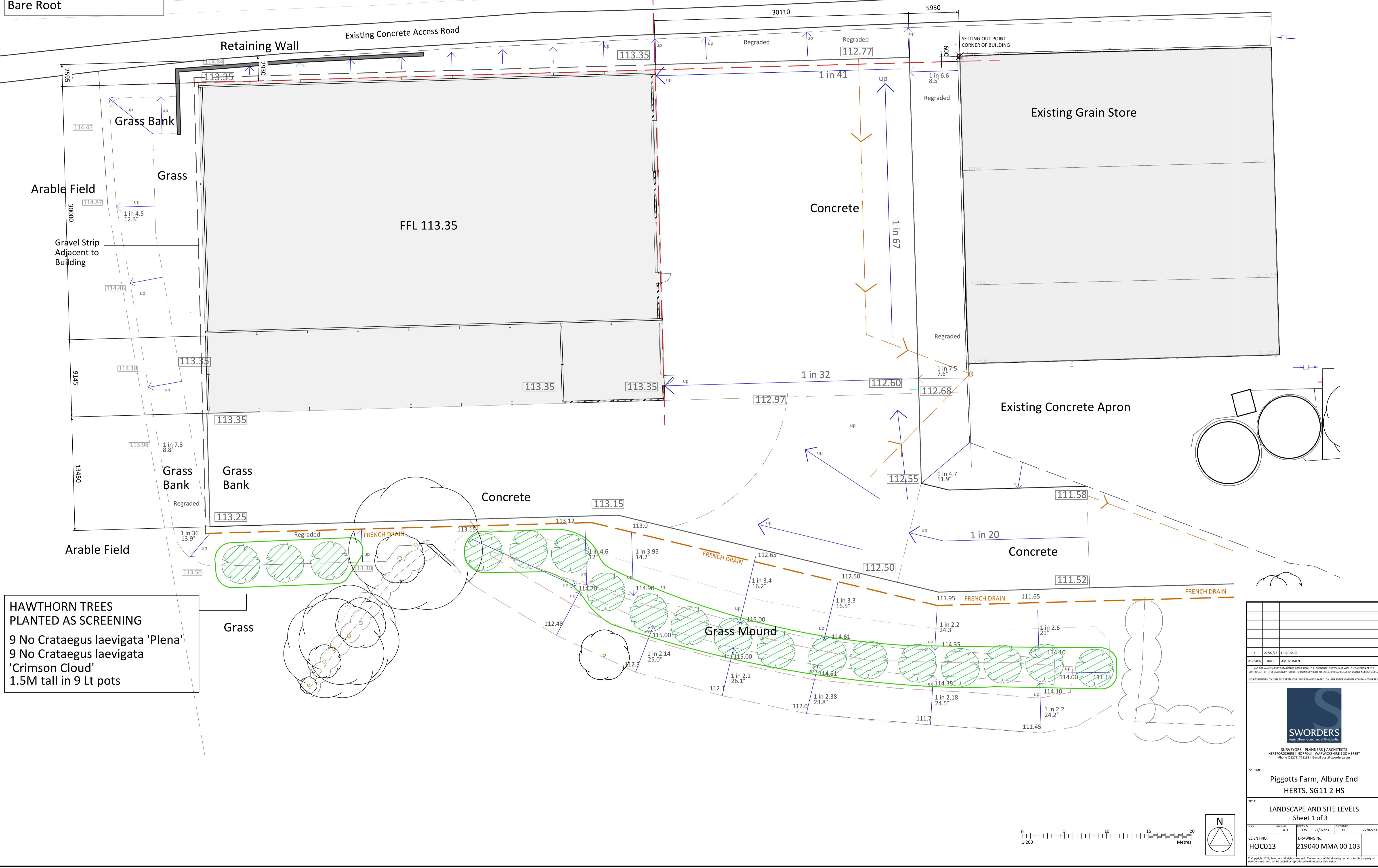

**HAWTHORN TREES
PLANTED AS SCREENING**
9 No Crataegus laevigata 'Plena'
9 No Crataegus laevigata
'Crimson Cloud'
1.5M tall in 9 Lt pots

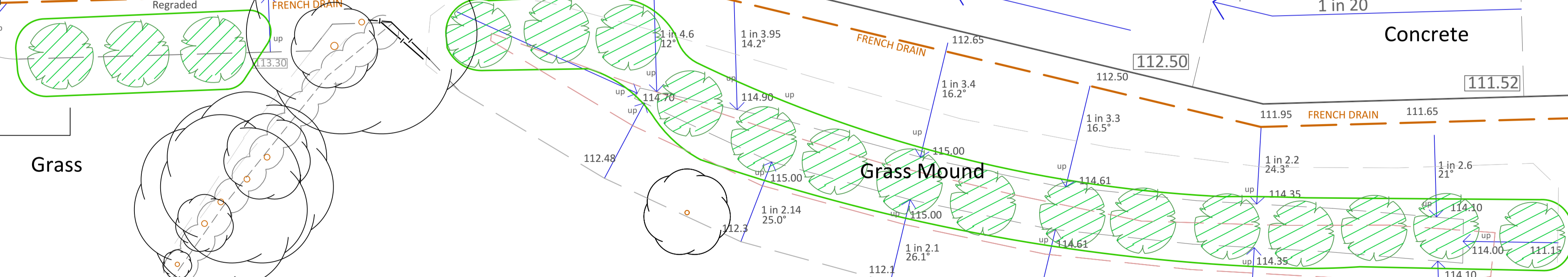

REVISION	DATE	AMENDMENT
/	27/02/23	FIRST ISSUE
<small>ANY ORNAMENTAL SURVEY DATA IS BASED UPON THE ORNAMENTAL SURVEY MAP WITH THE SANCTION OF THE CONTROLLER OF THE STATUTORY OFFICE. COPYRIGHT RESERVED. ORNAMENTAL SURVEY LICENSE NUMBER 10000000. NO RESPONSIBILITY CAN BE TAKEN FOR ANY RELIANCE BASED ON THE INFORMATION CONTAINED HEREIN.</small>		
 SWORDERS <small>Agricultural Commercial Residential</small>		
<small>SURVEYORS PLANNERS ARCHITECTS HERTFORDSHIRE NORFOLK WARRICKSHIRE SOMERSET Phone: 01273 771188 E-mail: info@sworders.com</small>		
Scheme: Piggotts Farm, Albury End HERTS. SG11 2 HS		
Title: LANDSCAPE AND SITE LEVELS Sheet 1 of 3		
DATE	SCALE	DATE
27/02/23	1:200	27/02/23
CLIENT NO.	DRAWING NO.	DATE
HOC013	219040 MMA 00 103	27/02/23
<small>© Copyright 2023, Sworders. All rights reserved. The contents of this drawing remain the sole property of Sworders and must not be copied or reproduced without prior permission.</small>		

