

A :: Block Plan
01 scale: 1:200



A :: Existing Ground Floor Plan
01 scale: 1:100



A :: Proposed Ground Floor Plan
01 scale: 1:100

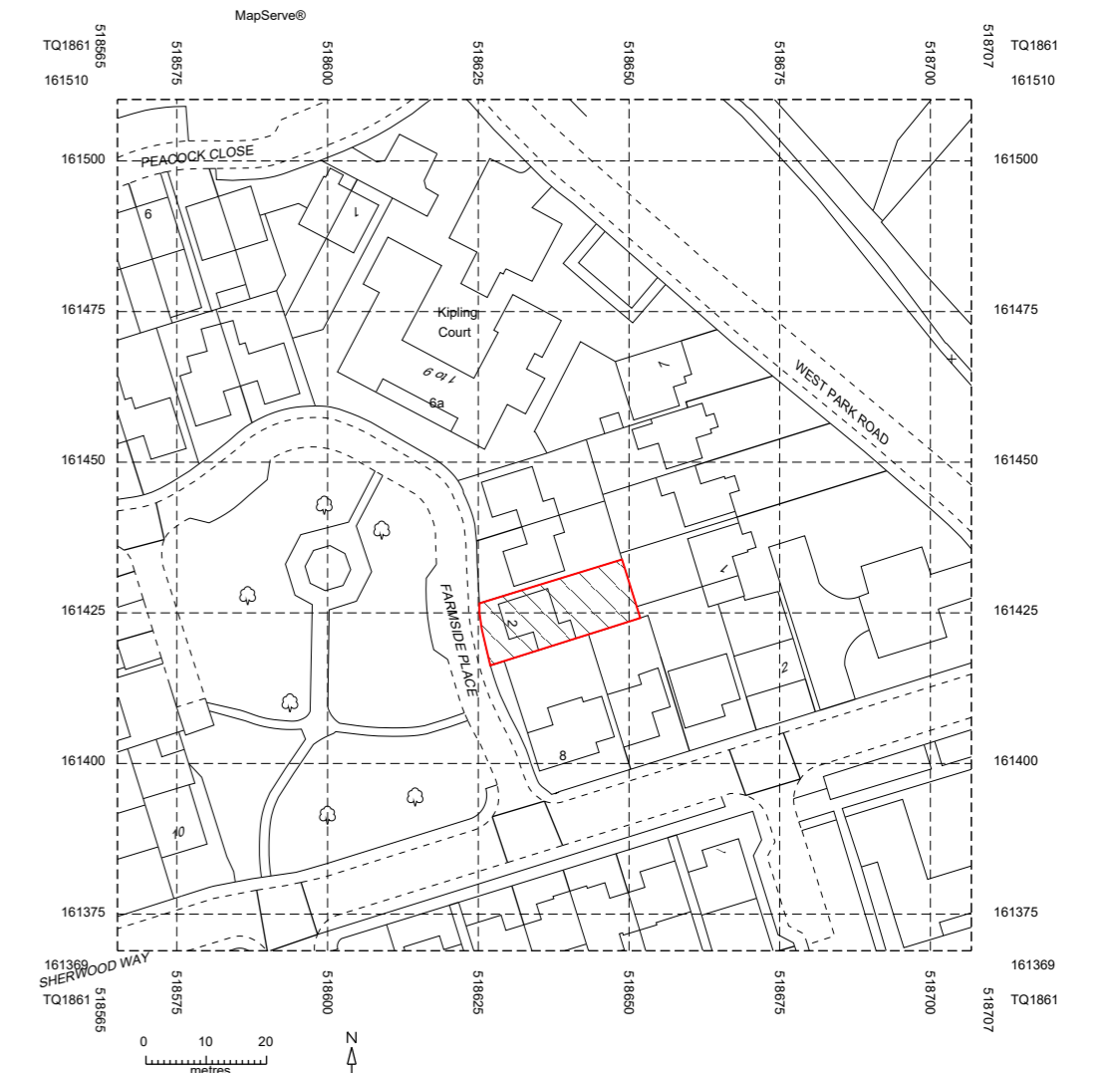

A :: Location Plan
01 scale: 1:1250

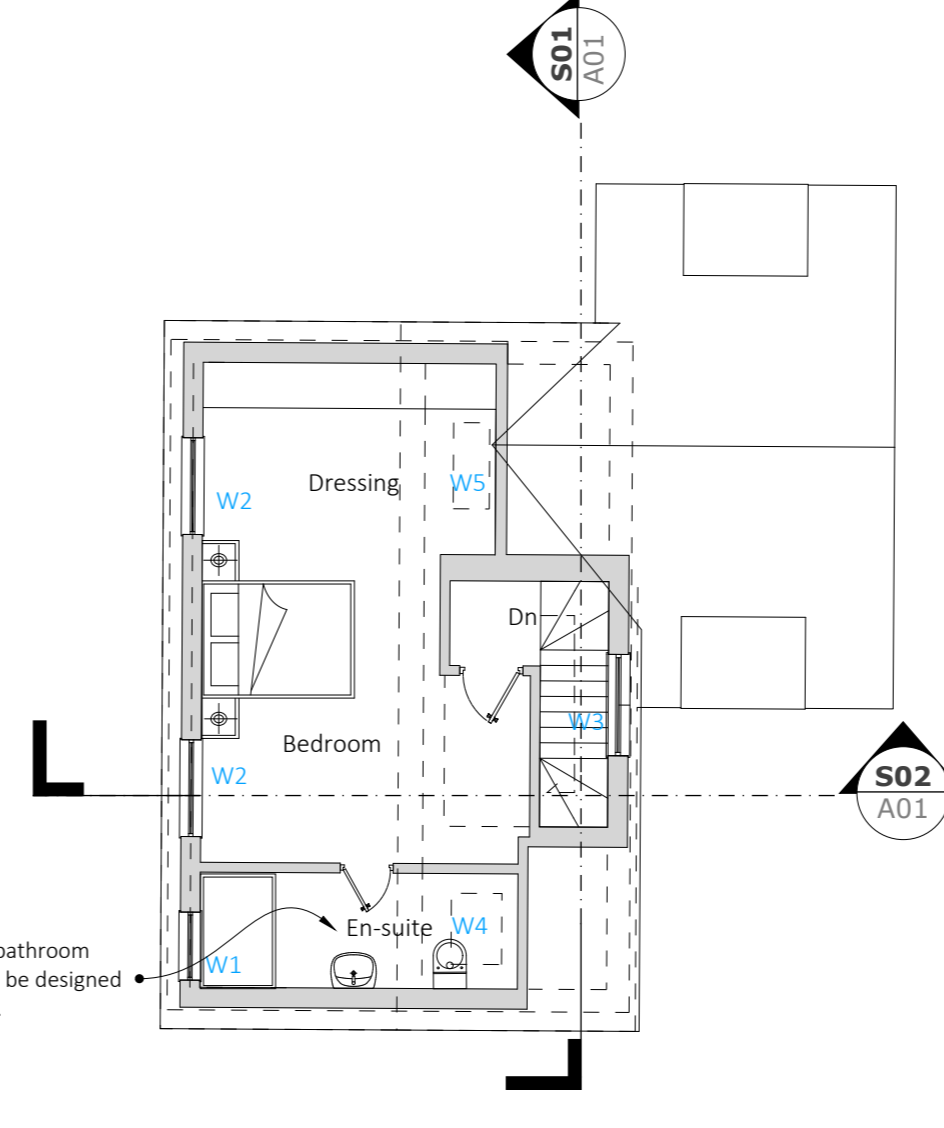
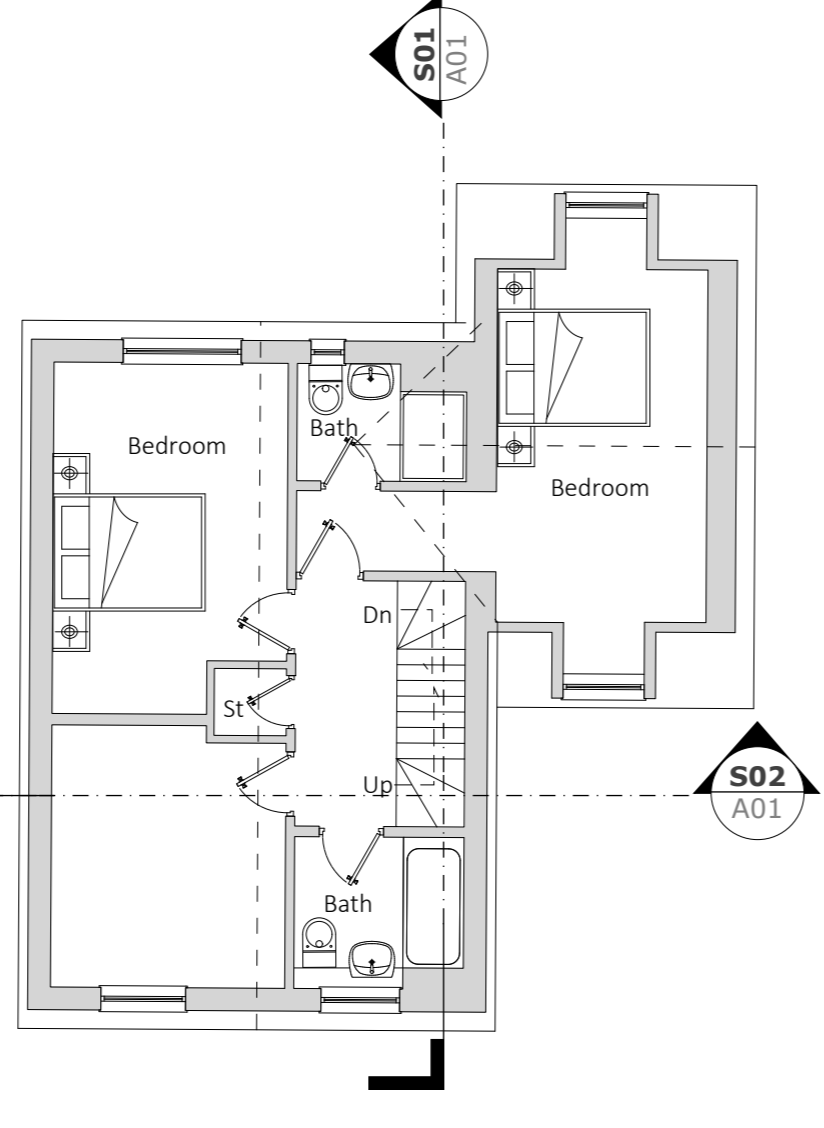
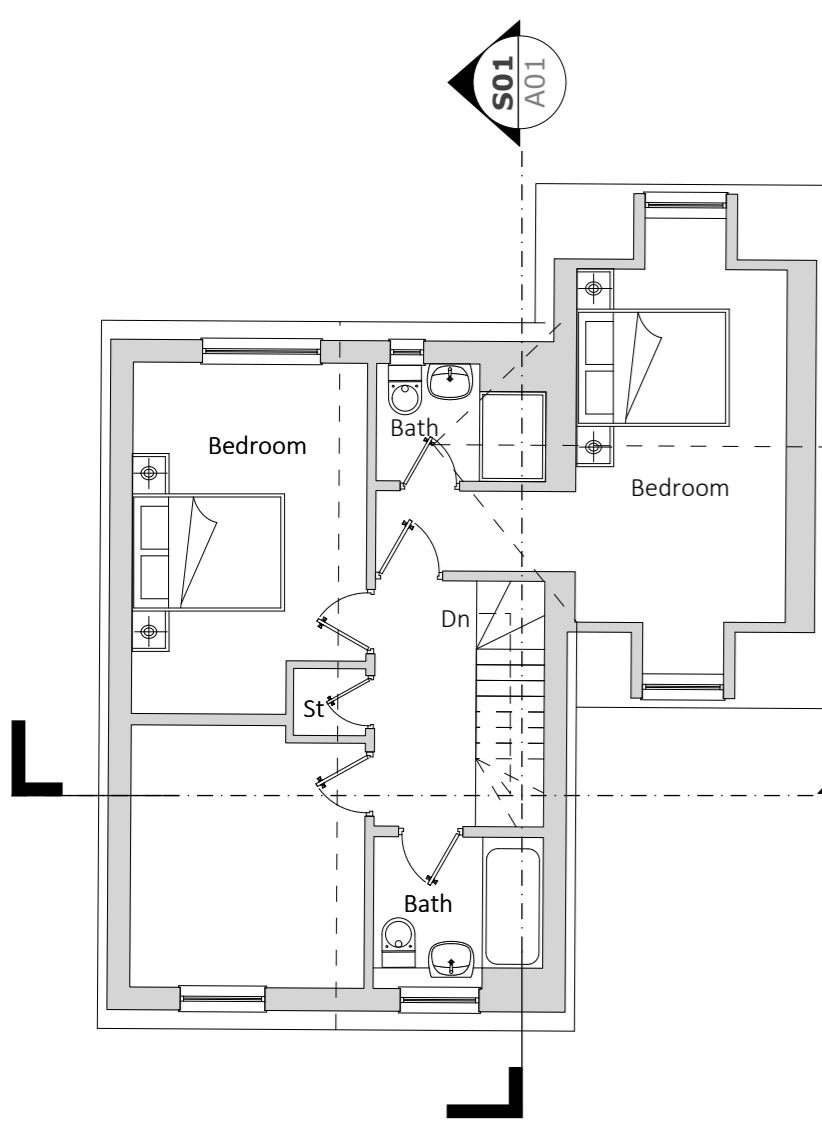

Notional bathroom design, to be designed by others.

A :: Existing First Floor Plan
01 scale: 1:100

A :: Proposed First Floor Plan
01 scale: 1:100

A :: Proposed Second Floor Plan
01 scale: 1:100

Windows Schedule				
S. NO.	No	TYPE	SILL	Window Height
W1	1	900	1000	1000
W2	2	1280	1000	1000
W3	1	1360	600	1240
W4	1	Velux PK04 940x980	1500 Obscured glazing	
W5	1	Velux SK01 1140x700	1700	

V1
Area of triangle = $b \cdot h / 2$
= $(2.43m \times 2.60m) / 2 = 3.15m$
Volume = $a \cdot l$
= $3.15 \times 3.78 = 11.94m^3$

V2
Area of triangle = $b \cdot h / 2$
= $(2.36m \times 2.53m) / 2 = 2.98m$
Volume = $a \cdot l$
= $2.98 \times 8.79 = 26.24m^3$

Gross Proposed Volume = $11.94 + 26.24 = 38.18m^3$

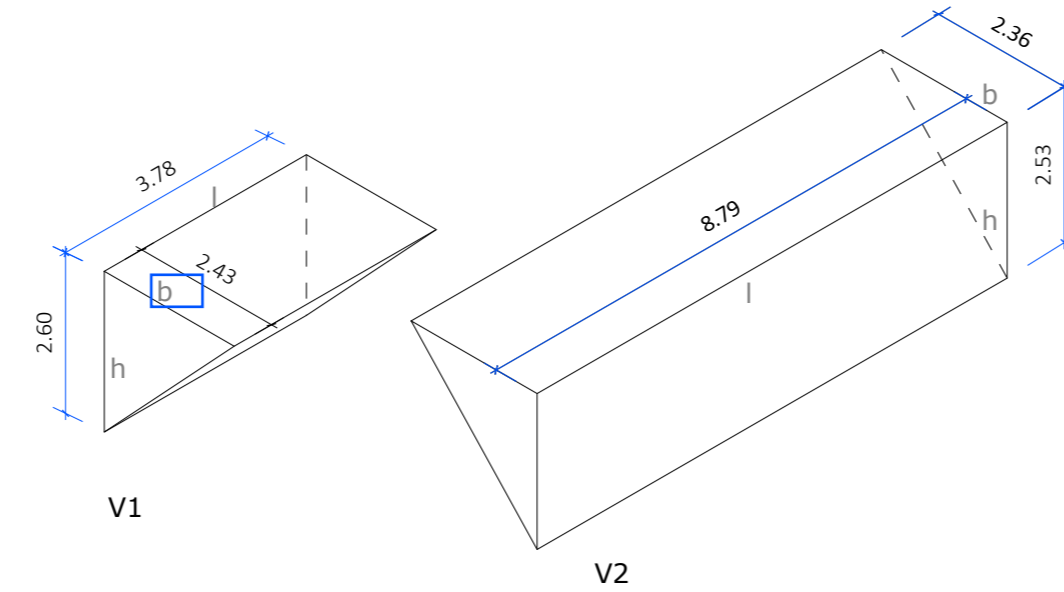

S01 :: Proposed Section 1
A01 scale: 1:100



S02 :: Proposed Section 2
A01 scale: 1:100



A :: Existing West Elevation
01 scale: 1:100



A :: Existing East Elevation
01 scale: 1:100



A :: Proposed West Elevation
01 scale: 1:100



A :: Proposed East Elevation
01 scale: 1:100

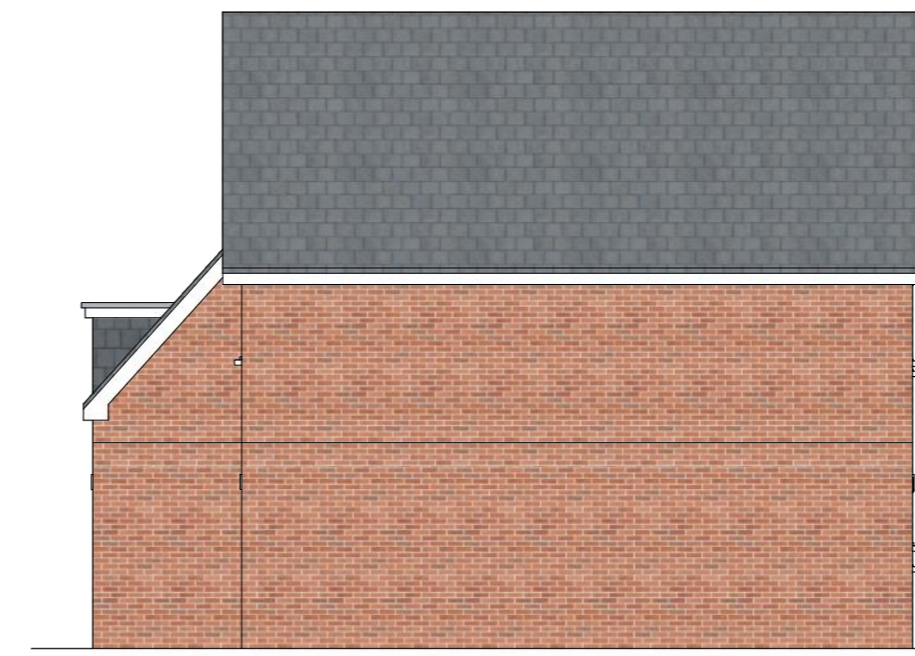

A :: Existing North Elevation
01 scale: 1:100



A :: Existing South Elevation
01 scale: 1:100



A :: Proposed South Elevation
01 scale: 1:100

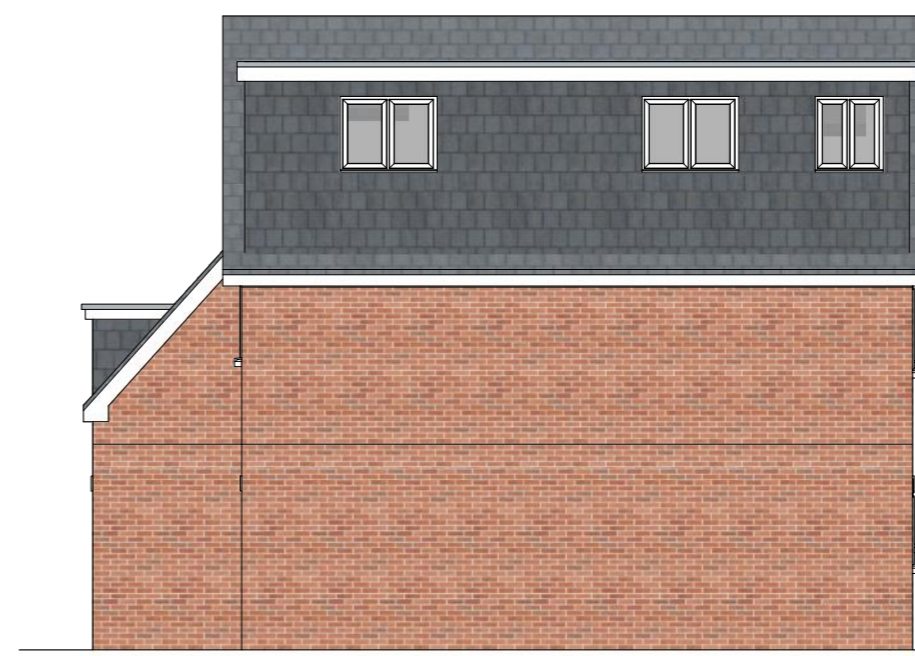

A :: Proposed North Elevation
01 scale: 1:100

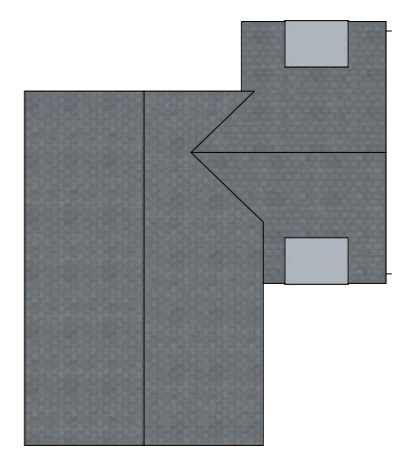

A :: Existing Roof Plan
01 scale: 1:200

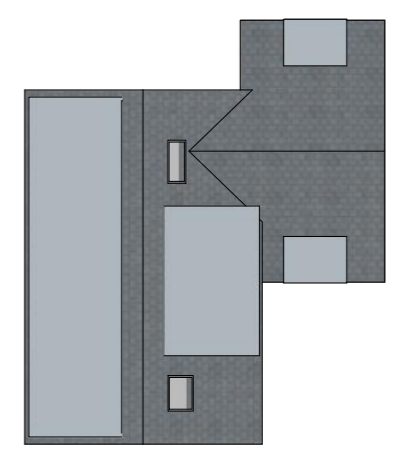

A :: Proposed Roof Plan
01 scale: 1:200

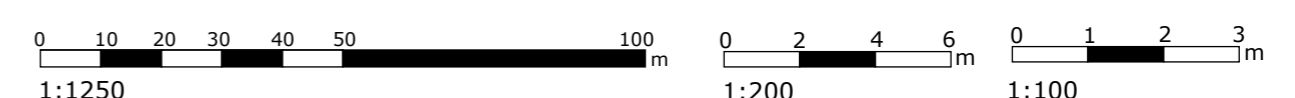

Surrey Lofts Walton Limited
Hassell Acres
Rus Hill
Charlwood
RH16 6EL
0203 6039777
www.surreylofts.co.uk
sales@surreylofts.co.uk

All dimensions must be checked on site and not scaled from this drawing, apart from the local authority.
Any works commencing on site prior to obtaining full planning and building regulations approval including full condition discharge, is entirely at the client's risk.
All building work is to be carried out in accordance with building regulations and to the satisfaction of the local authority and as such additional unforeseen building works may be required on site.
These drawings do not constitute full working drawings.
All drawings are copyright of Surrey Lofts Walton Ltd and may not be copied or reproduced by any third party without prior written consent.
Party with actions are the responsibility of the client.

Address:
2 Farmside Place, Epsom
KT19 8GW

Client:
Norah Yap and Kee Wong

Title:
Loft Conversion

October 12, 2023

Rev2 - Addition of Volume Calcs
Paper Size A1



A 01