

GROUND FLOOR

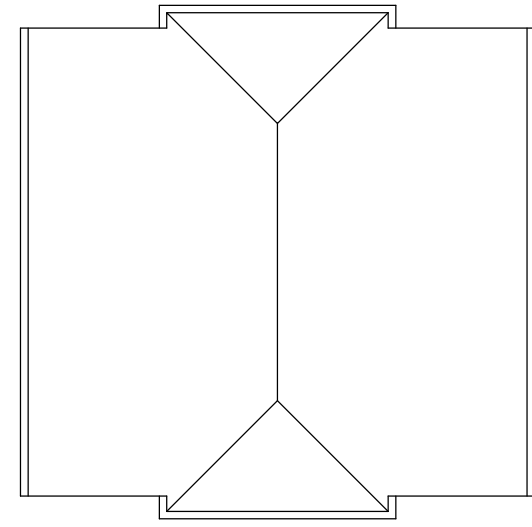

ROOF PLAN

PROPOSED MATERIALS

- WINDOWS - COLOURED UPVC DOUBLE GLAZED
- FASCIAS AND SOFFITS - WHITE UPVC
- RAINWATER GOODS - WHITE UPVC

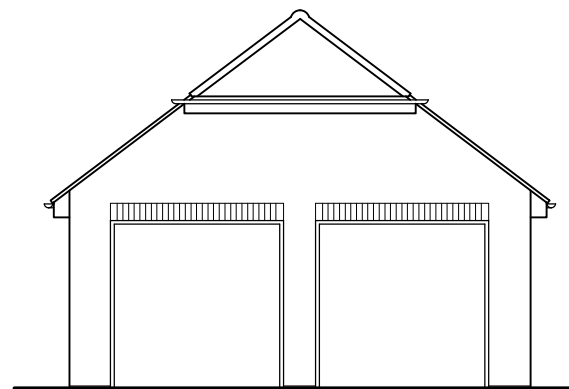

WEST ELEVATION

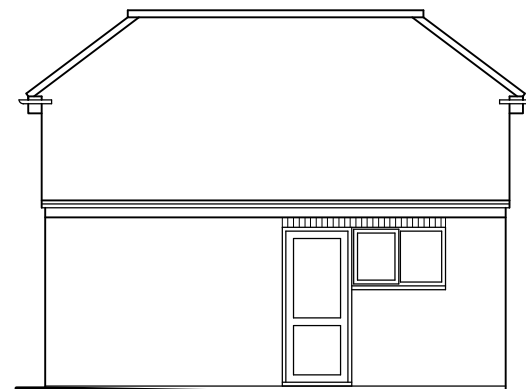

SOUTH ELEVATION

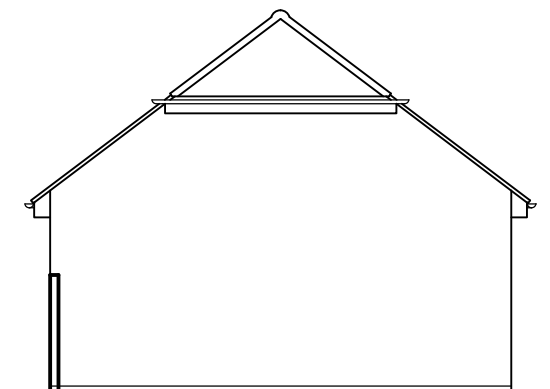

EAST ELEVATION

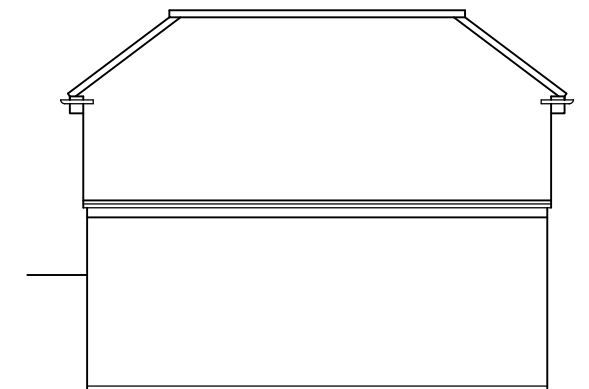

NORTH ELEVATION

