

ELEVATION OF BIFOLD DOORS 1:20

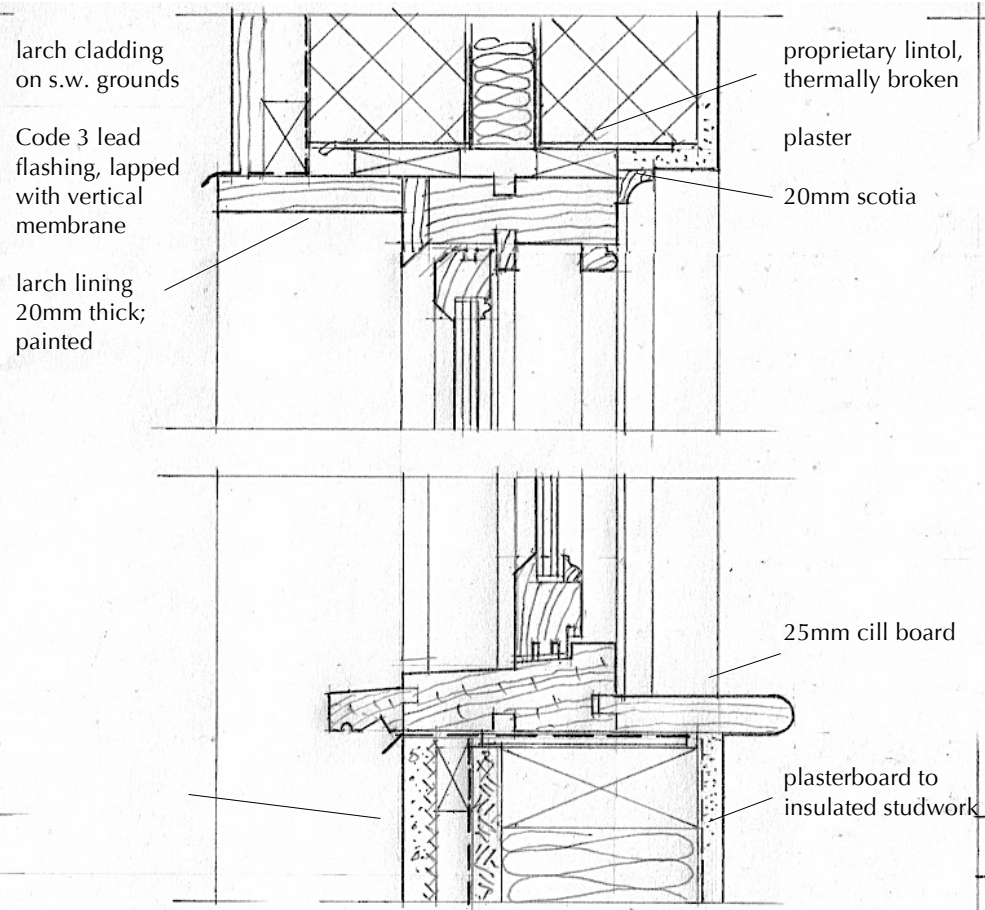

HEAD AND CILL SECTIONS 1:5

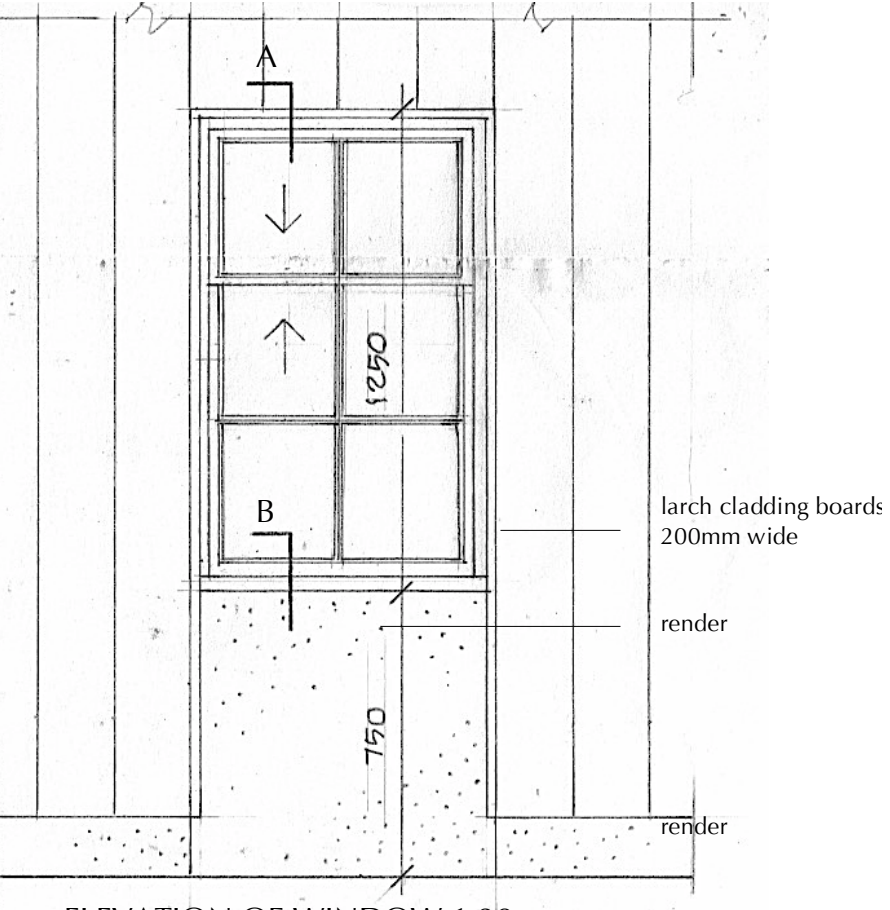

ELEVATION OF WINDOW 1:20

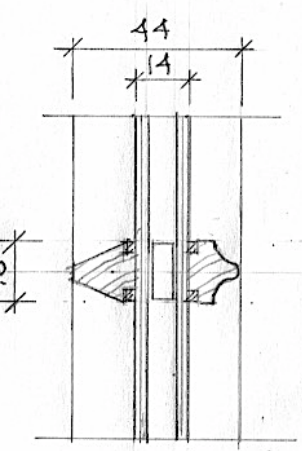

DETAIL OF GLAZING BAR 1:2

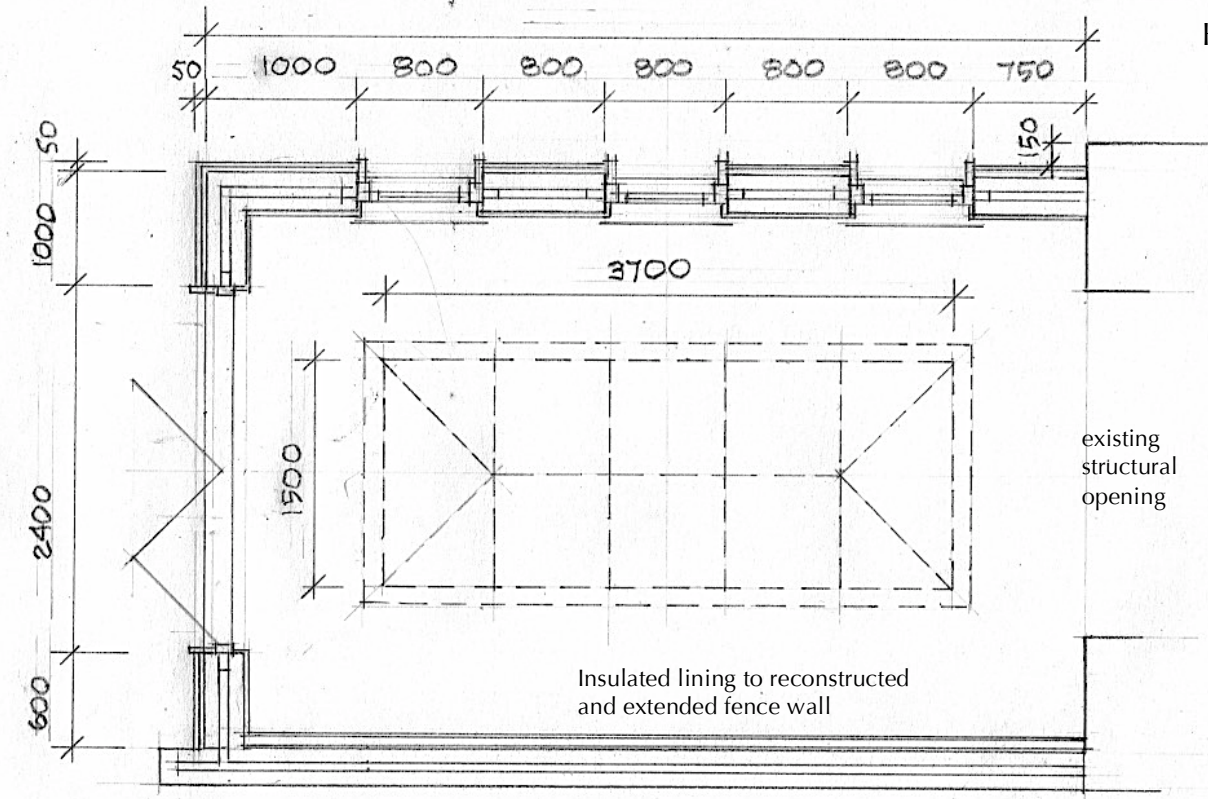

PLAN OF GARDEN ROOM 1:50

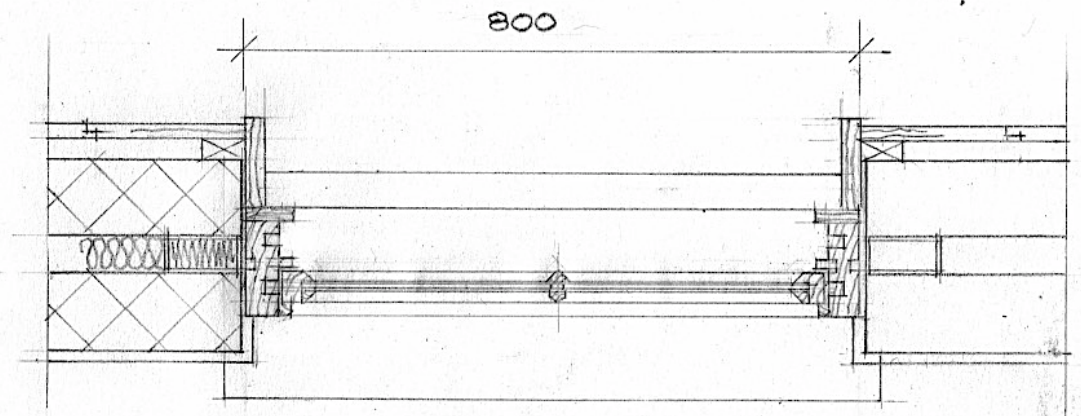

PLAN OF WINDOW ABOVE CILL 1:10

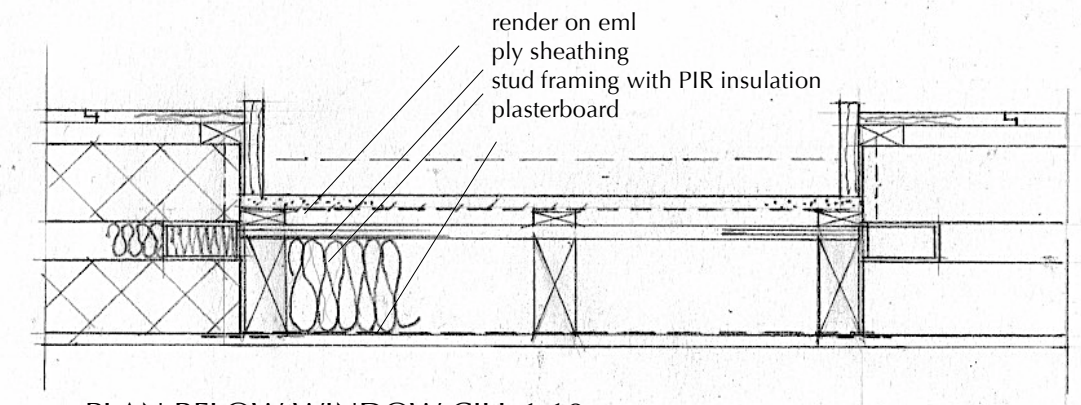

PLAN BELOW WINDOW CILL 1:10

NOTE

- 1 Not to be used for construction. For finalised dimensions and other constructional details refer to drawings of T Neal Ltd.
- 2 Joinery sections based on Bereco Heritage Slim-Line Sliding Sash Spiral Balance.
- 3 External joinery to be painted RAL 7003 Moss Grey, low sheen. Roof lantern light to be RAL 4016 Anthracite.

REVISION C - 10.10.23 - Additional notes.
REVISION B - 26.9.23 - Glazing bar detail

35 BROAD STREET, NEW ALRESFORD
Selected Details of Garden Room
1:50, 1:20, 1:10 @ A3

245

September 2023

Drwg No 245 D04C