

NOTES

- Dimensions of existing frames and structure to be confirmed on site.
- Trial pits required to confirm extent of existing footings.
- To be read in conjunction with Structural Engineers drawings.

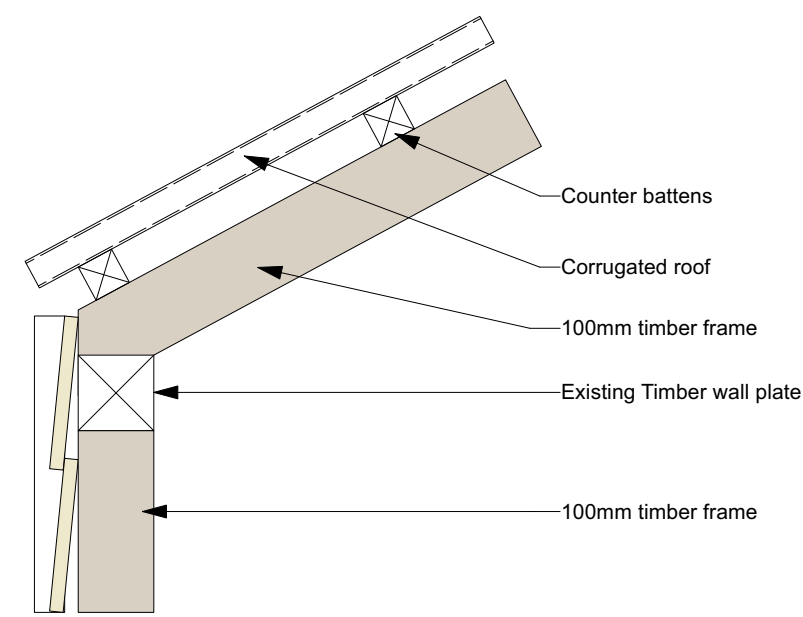

03 | EXISTING TYPICAL ROOF/WALL JUNCTION DETAIL (SECTION) 1:10

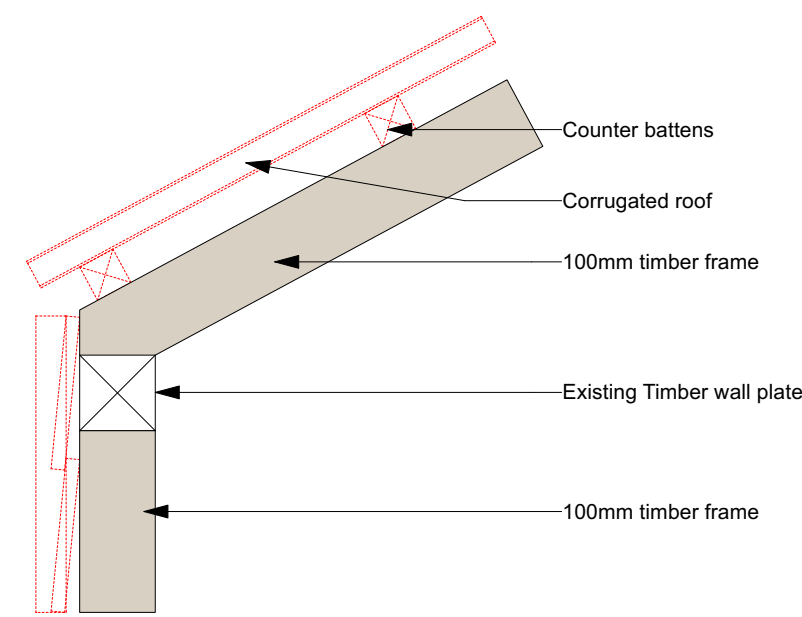

06 | DEMO TYPICAL ROOF/WALL JUNCTION DETAIL (SECTION) 1:10

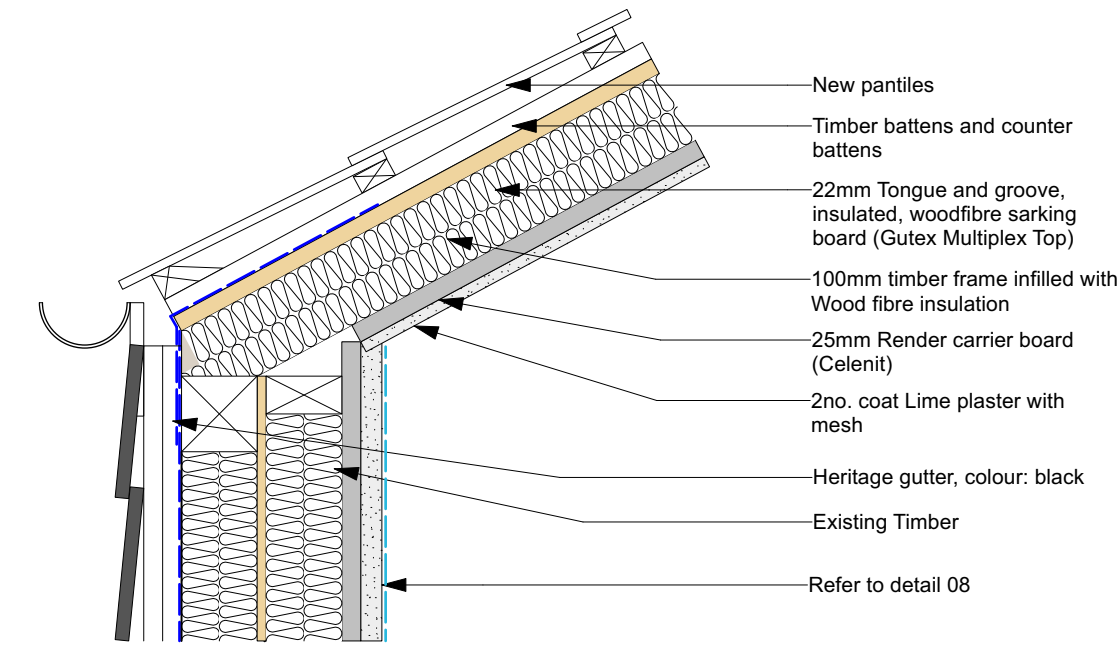

09 | TYPICAL ROOF/WALL JUNCTION DETAIL (SECTION) 1:10

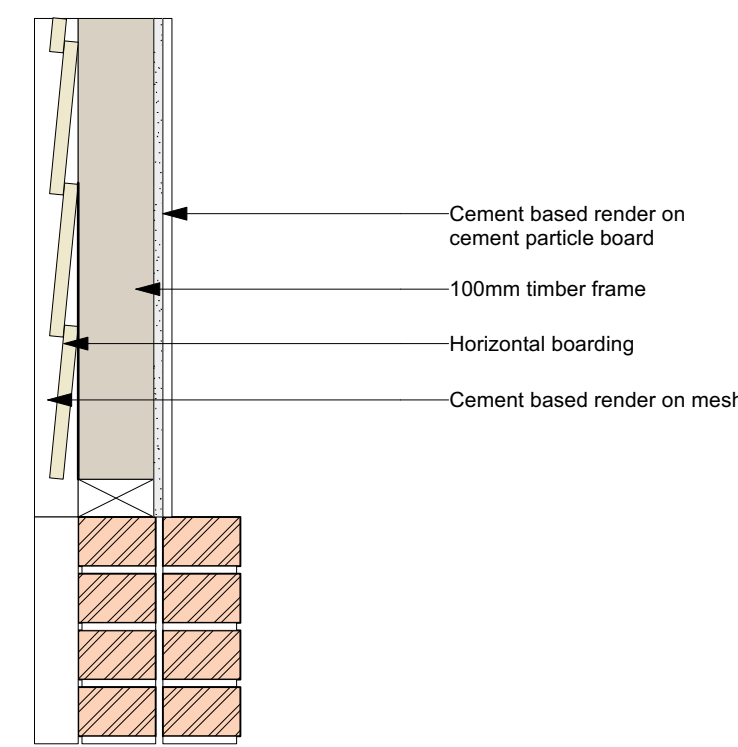

02 | EXISTING TYPICAL WALL DETAIL (SECTION) 1:10

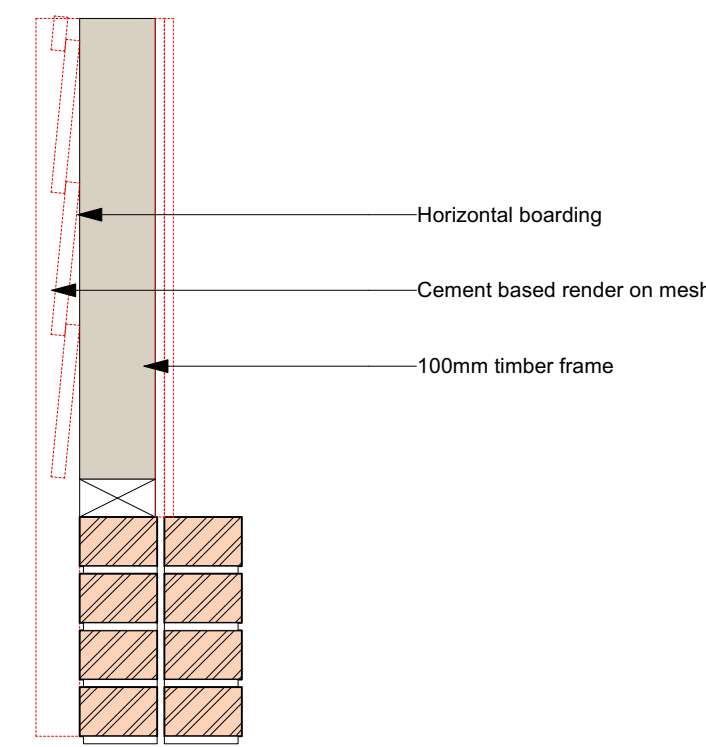

05 | DEMO TYPICAL WALL DETAIL (SECTION) 1:10

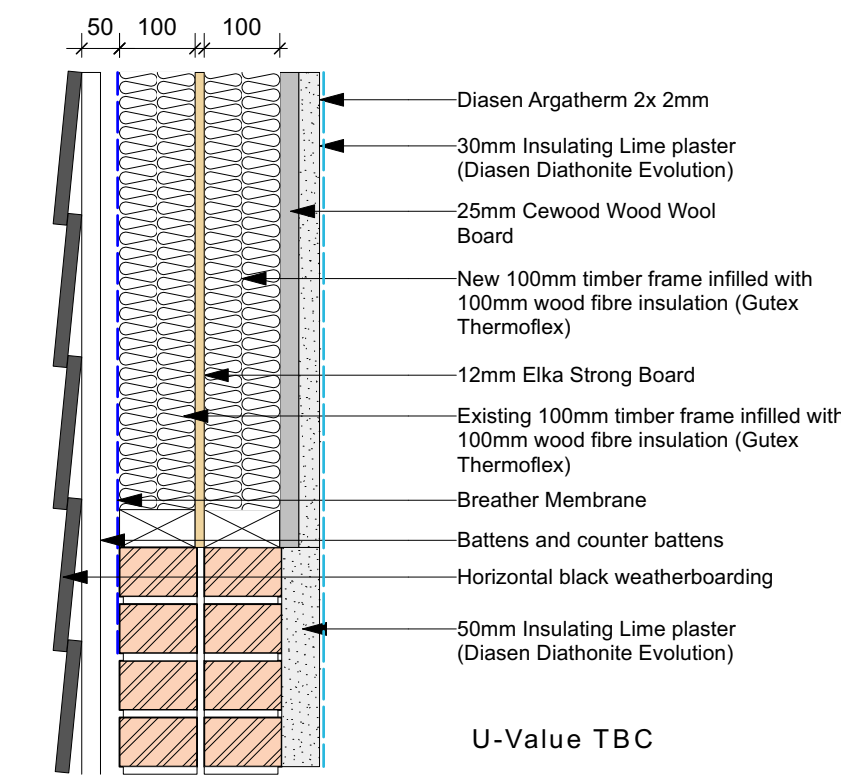

08 | TYPICAL WALL DETAIL (SECTION) 1:10

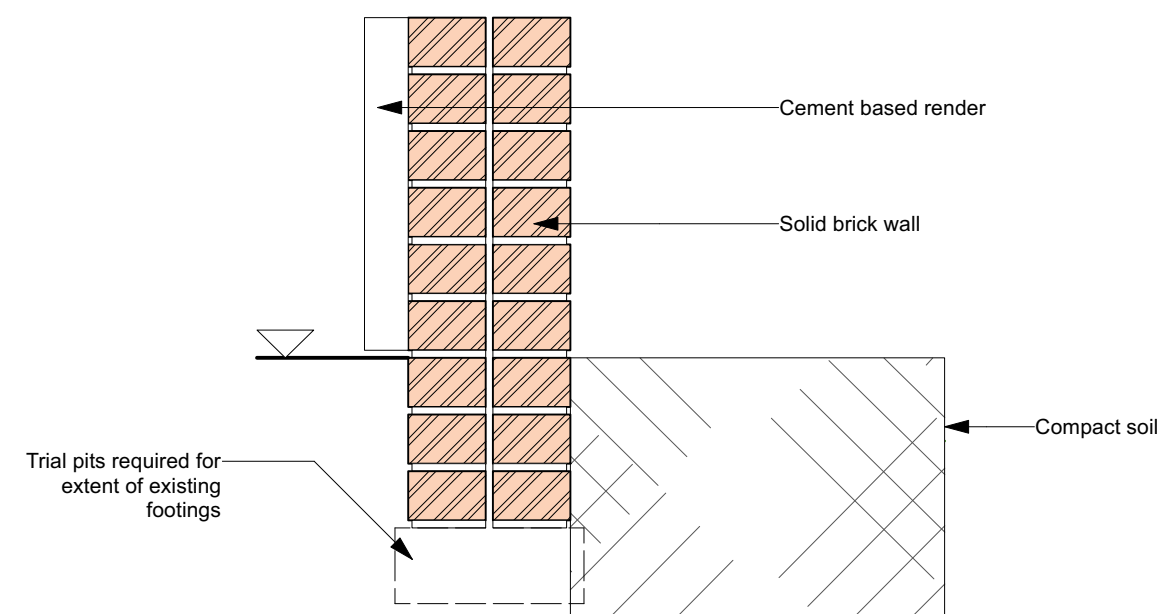

01 | EXISTING TYPICAL FLOOR/WALL JUNCTION DETAIL (SECTION) 1:10

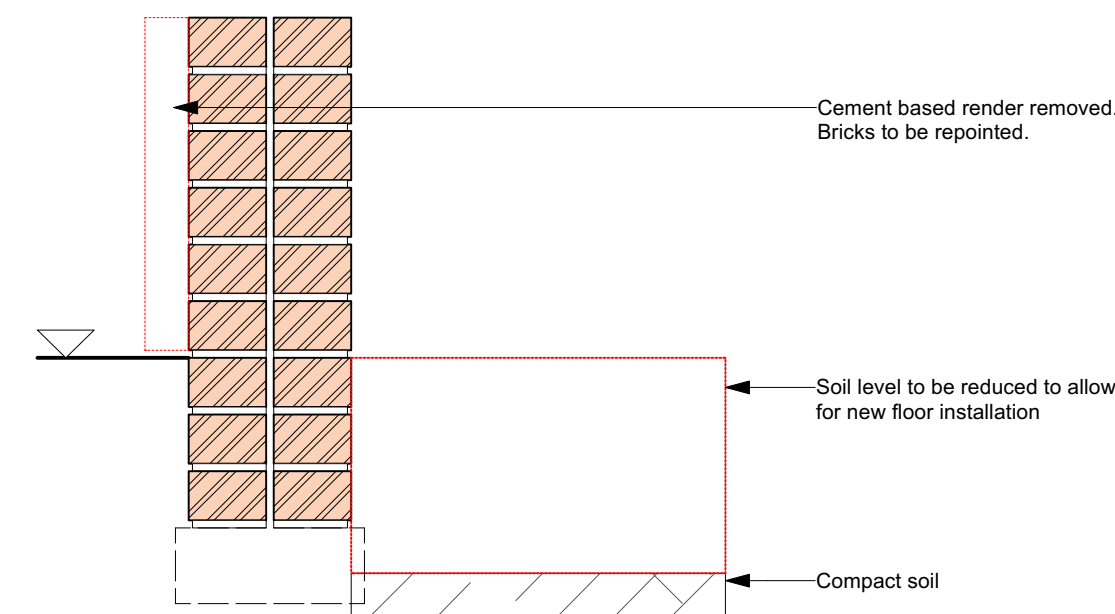

04 | DEMO TYPICAL FLOOR/WALL JUNCTION DETAIL (SECTION) 1:10

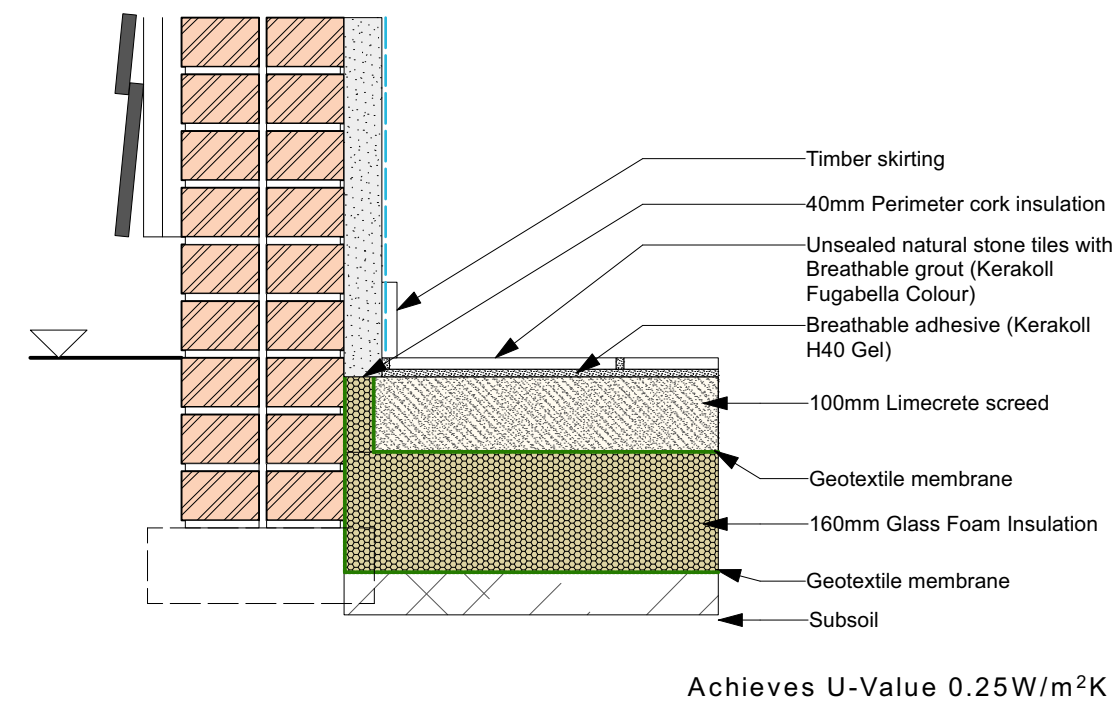

07 | TYPICAL FLOOR/WALL JUNCTION DETAIL - SCREED (SECTION) 1:10

BUILDING 2 SHELTER EXISTING DETAILS

BUILDING 2 SHELTER DEMO DETAILS

BUILDING 2 SHELTER PROPOSED DETAILS

REVISION	DESCRIPTION	DATE	DRAWN	CHECK

5847 PA_53

Plot 7 Shelter External Fabric Details

SCALE: 1:10 SHEET SIZE

ISSUE DATE: 13/07/2023

AUTHOR: EB CHECK

PROJECT: Newhouse Farm Conversion
Newhouse Farm, Hall Road
Great Bromley, Colchester, CO7 7TP

CLIENT: INOVA

STATUS: PLANNING



Market Place / Highgate / South / IPT 52K
T / 01473 827952 E / enquiries@wv-architects.co.uk
Do not scale from drawing; work to figured dimensions only.
Copyright © Wincer Kievenaar Architects Limited
5847_Building_1_Details.vwx