

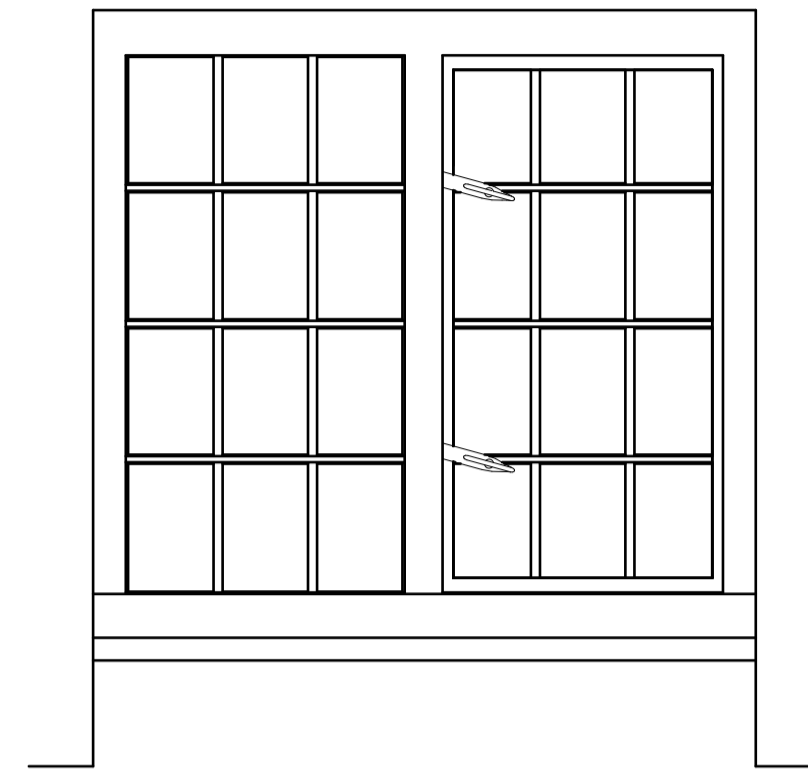

EXISTING EXTERNAL ELEVATION

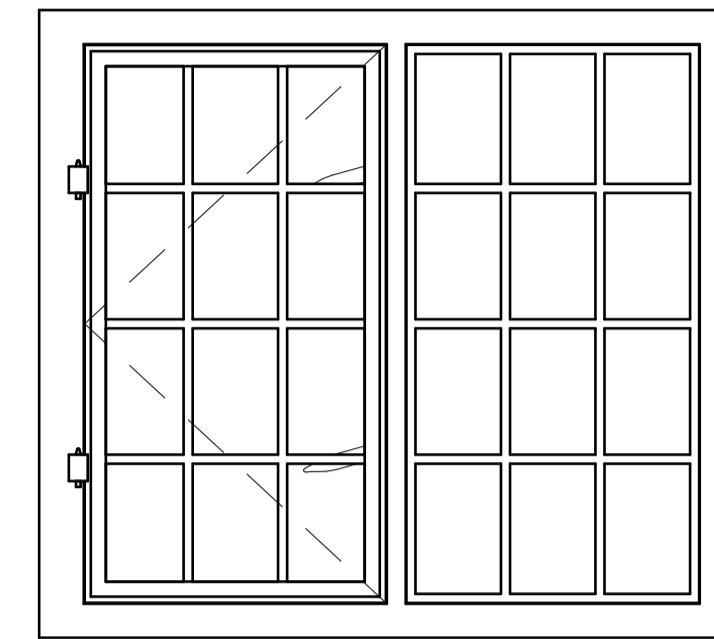

EXISTING INTERNAL ELEVATION 1:10



EXISTING EXTERNAL ELEVATION 1:10

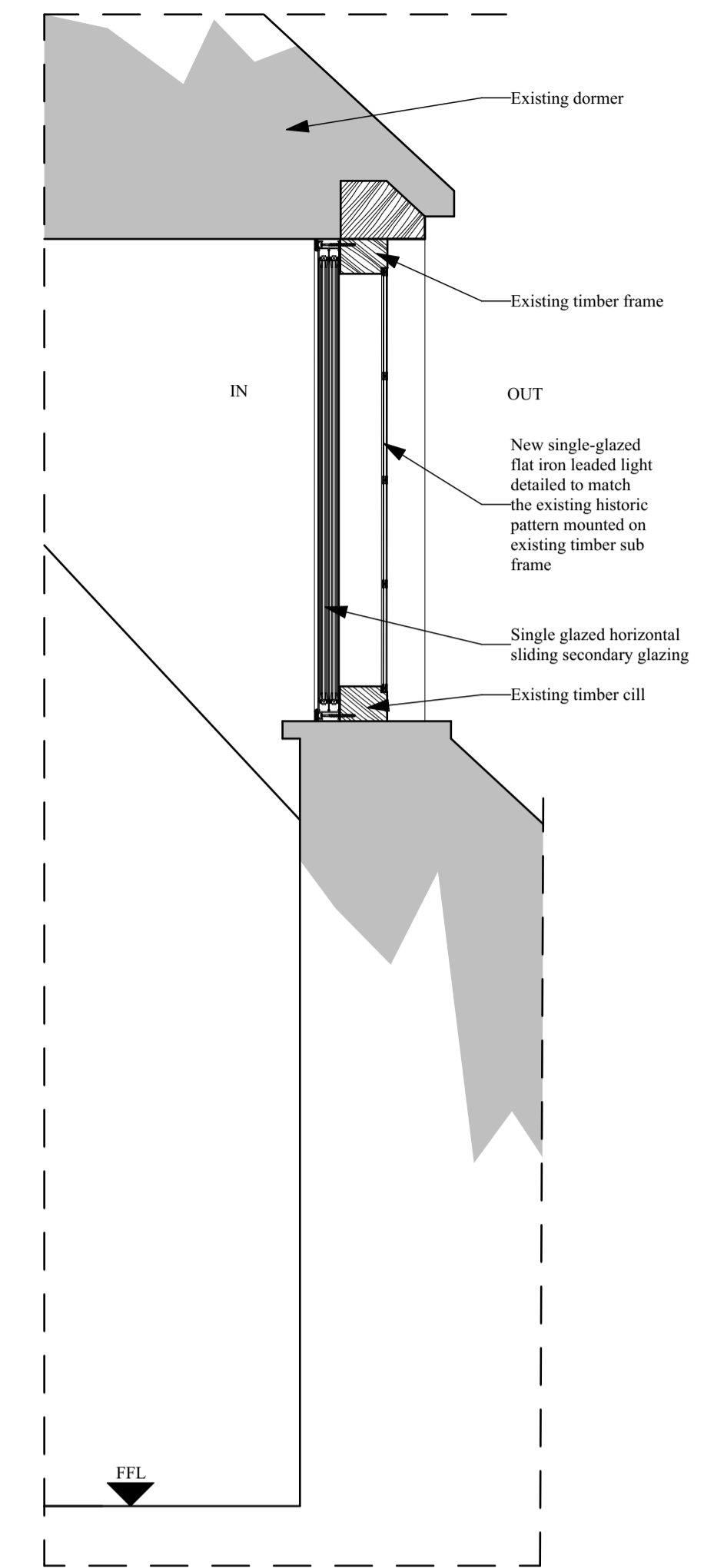

SECTION AS PROPOSED 1:10

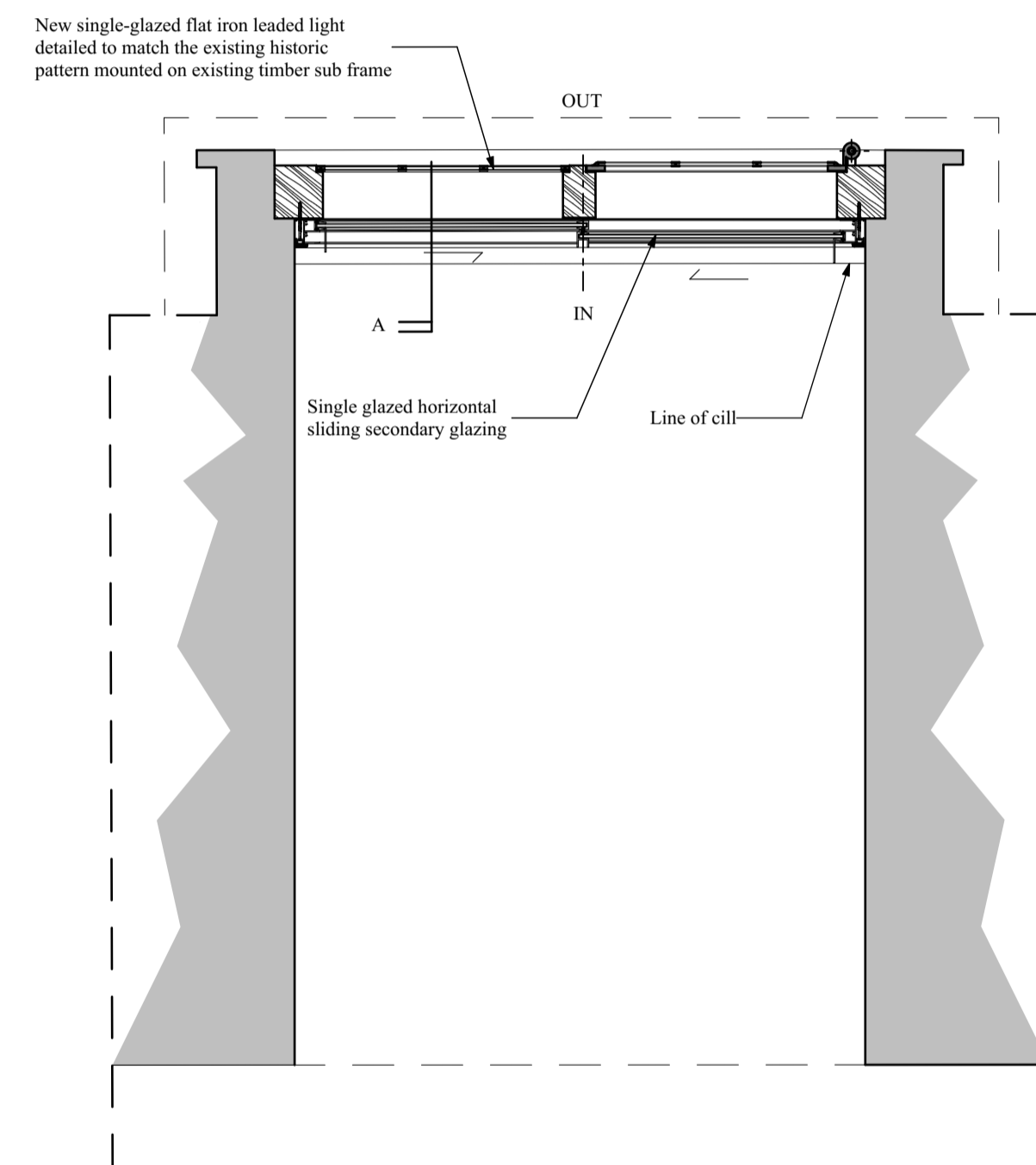

PLAN AS PROPOSED 1:10
WF16

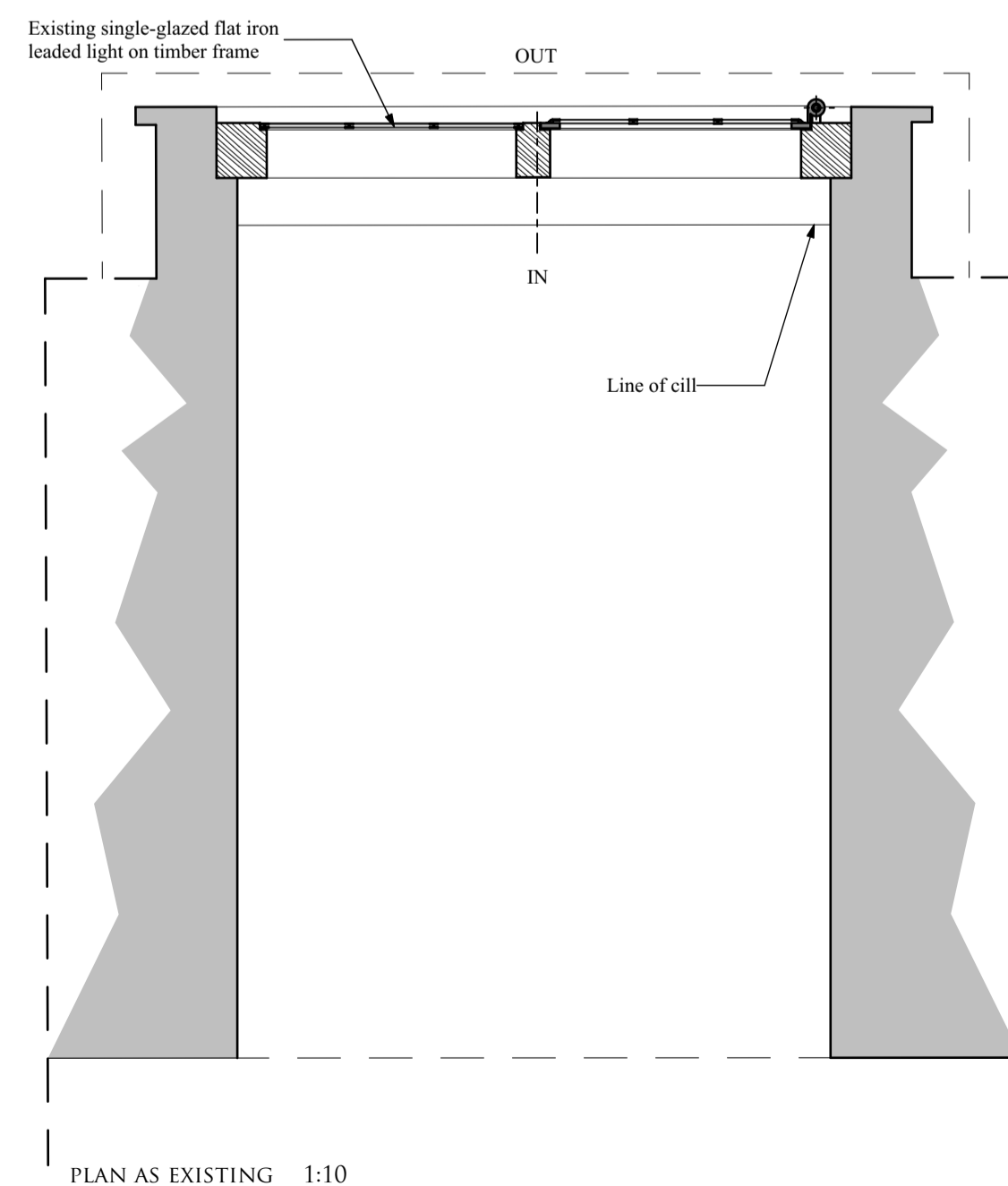

PLAN AS EXISTING 1:10
WF16

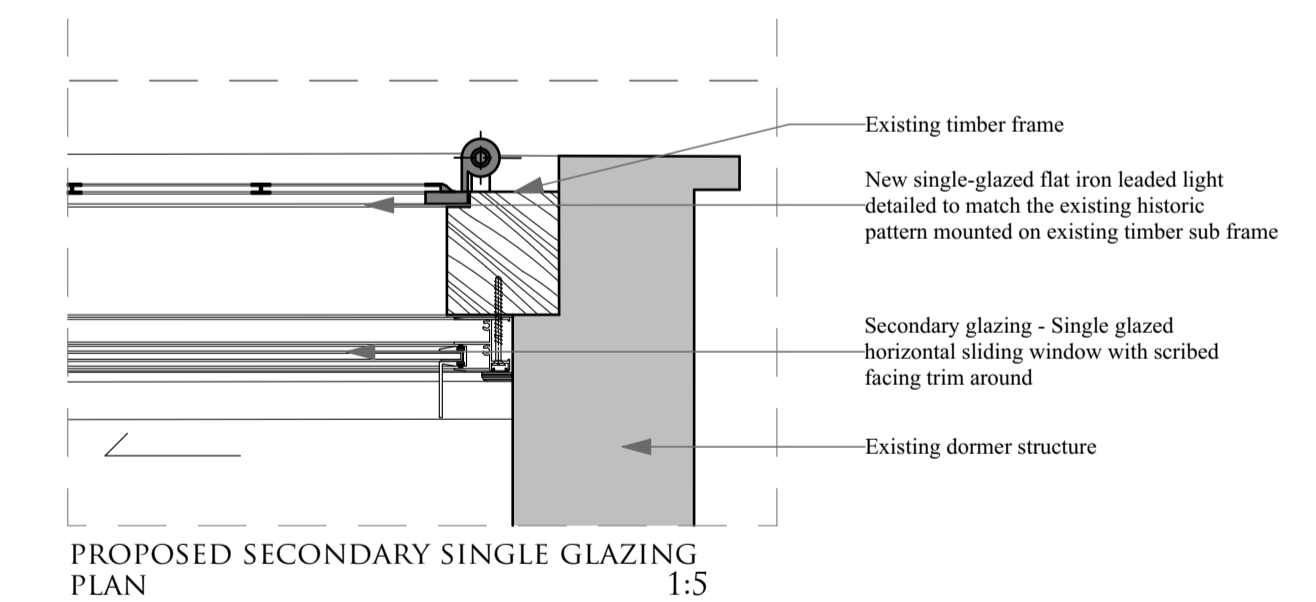

PROPOSED SECONDARY SINGLE GLAZING PLAN 1:5



EXISTING INTERNAL ELEVATION



PROPOSED SECONDARY SINGLE SLIDING GLAZING

REV	DATE	NOTES
A	14.09.23	Planning status indicated. External window updated to match existing. As existing window plan added.

PLANNING

CRAIG HAMILTON ARCHITECTS LTD
 COED MAWR FARM, HUNDRED HOUSE, RADNORSHIRE LD1 5RP · T:01982 553312
 OLD STABLE BLOCK, INCUBIVE SPACE, HURSELEY PARK ROAD, HURSELEY SO21 2JN

PROJECT: THE OLD RECTORY, WITHINGTON
 DRAWING TITLE: COTTAGE DORMER WINDOW DETAILS
 DRAWING N^o: 0503/PL35 REV: A
 DATE: JULY 2023 SCALE: 1:10, 1:5@ A1
 DRAWN BY: MS