

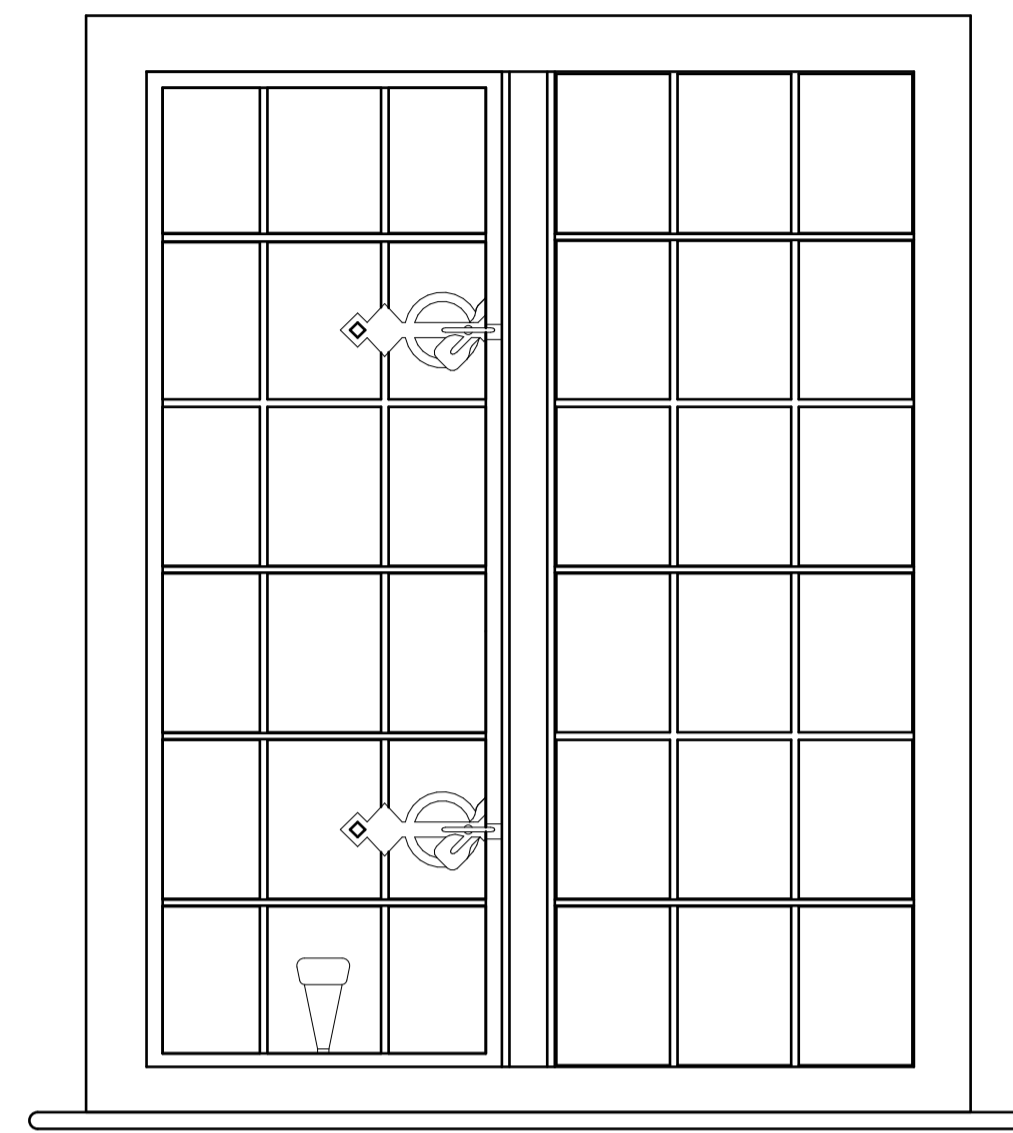

EXISTING EXTERNAL ELEVATION

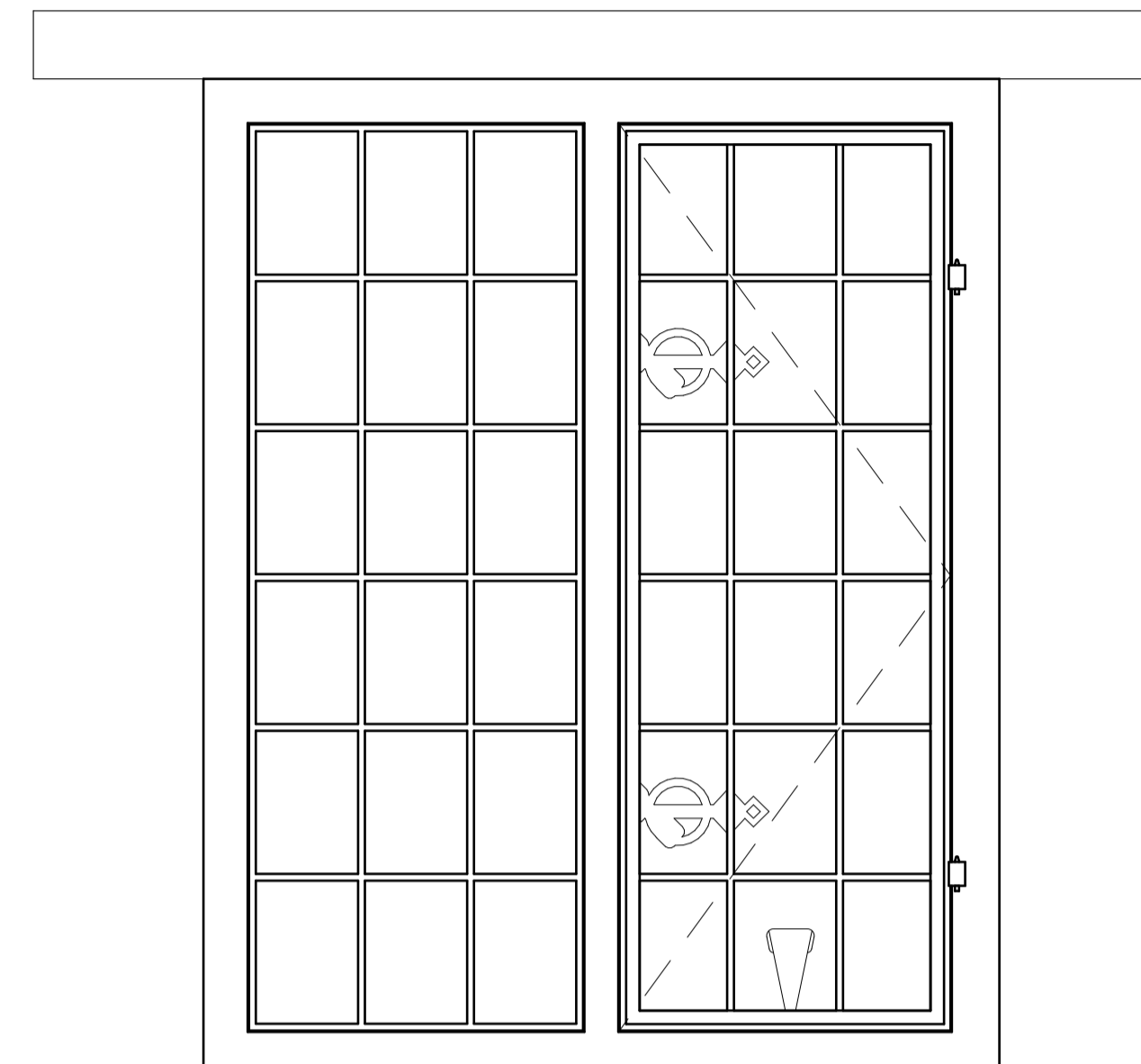

EXISTING INTERNAL ELEVATION 1:10



EXISTING EXTERNAL ELEVATION 1:10

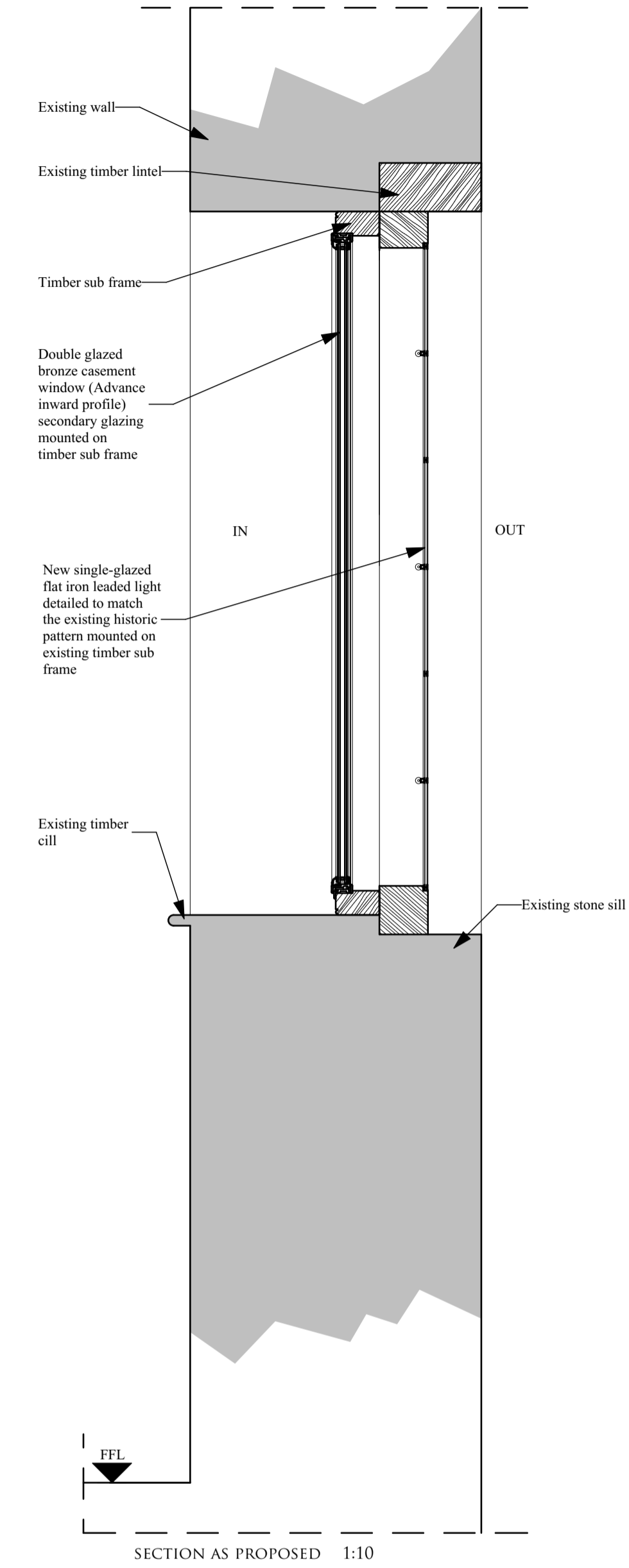

SECTION AS PROPOSED 1:10



EXISTING INTERNAL ELEVATION

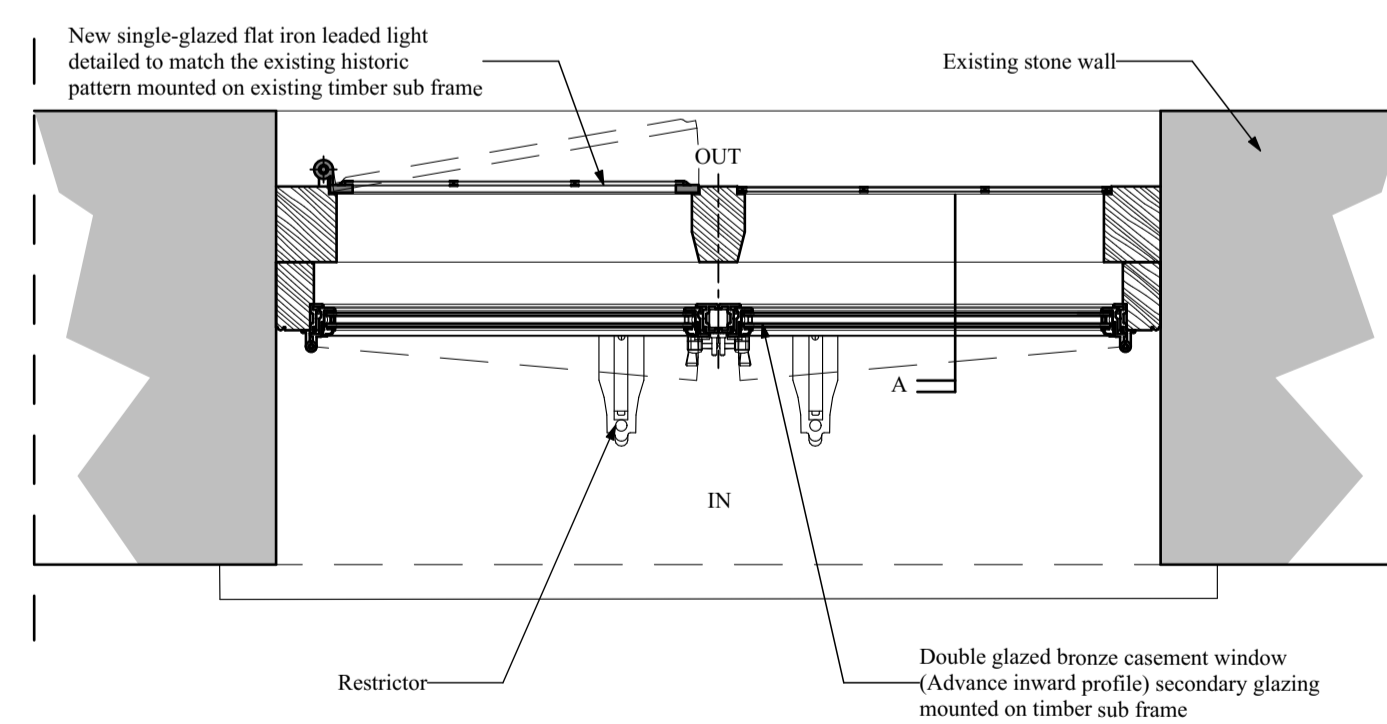

PLAN AS PROPOSED 1:10  
WF13 & WF14

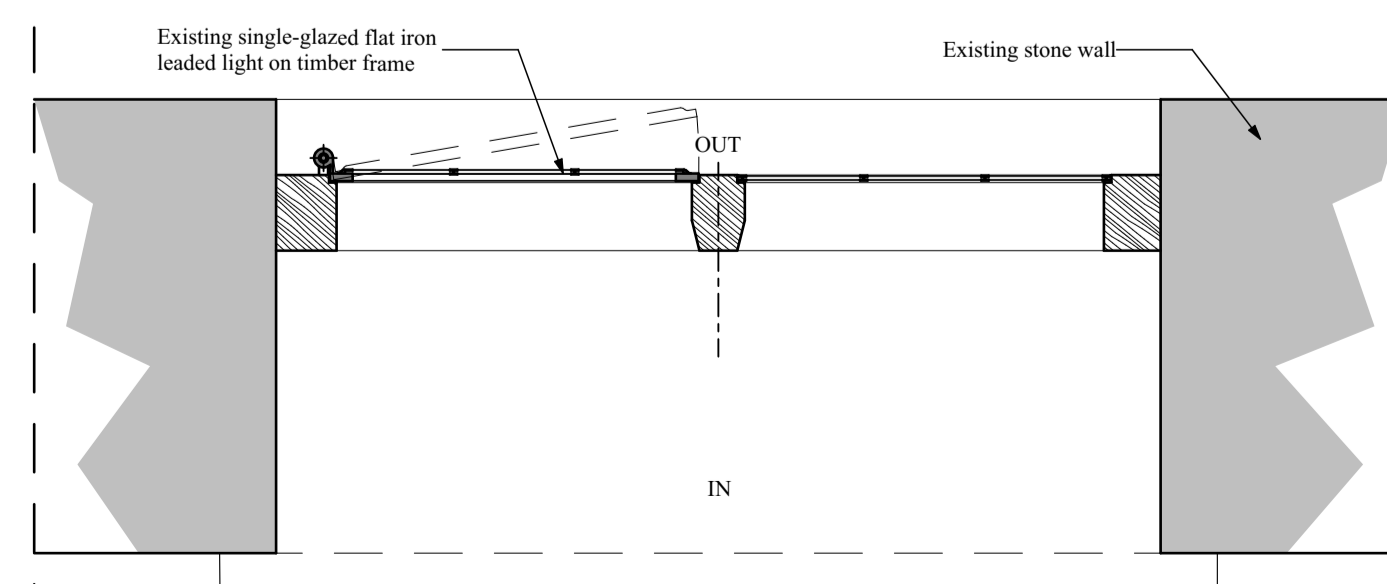

PLAN AS EXISTING 1:10  
WF13 & WF14

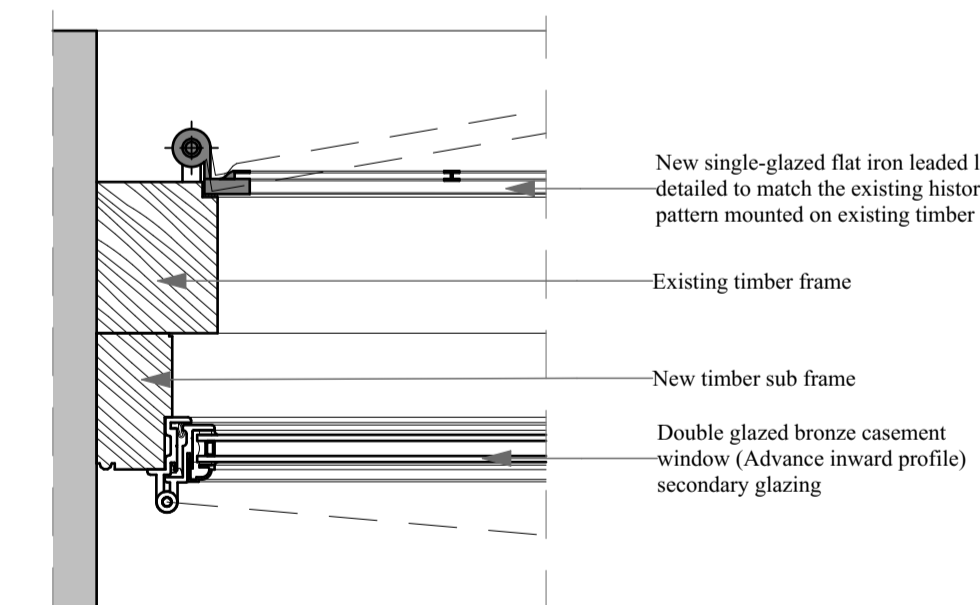

PROPOSED SECONDARY DOUBLE  
GLAZING SUB FRAME DETAIL 1:5



PROPOSED SECONDARY DOUBLE GLAZING

| REV | DATE     | NOTES  |
|-----|----------|--|
| A   | 14.09.23 | Planning status indicated. External window updated to match existing. As existing window plan added. |

## PLANNING

**CRAIG HAMILTON ARCHITECTS LTD**  
COED MAWR FARM, HUNDRED HOUSE, RADNORSHIRE LD1 5RP · T: 01982 553312  
OLD STABLE BLOCK, INCUBIVE SPACE, HURSLEY PARK ROAD, HURSLEY SO21 2JN

PROJECT: THE OLD RECTORY, WITHINGTON  
DRAWING TITLE: NEW LAUNDRY EAST WINDOW DETAILS  
DRAWING N<sup>o</sup>: 0503/PL33 REV: A  
DATE: JULY 2023 SCALE: 1:10, 1:5@ A1  
DRAWN BY: MS