



Tree Re-survey  
Arboricultural Impact Assessment  
& Tree Protection Plan

Proposed Extension to  
Lowen House  
Roseland Parc  
Tregony  
Truro  
TR2 5PD

Reference: 2001-5-C

Report Date: May 2023  
amended Aug & September 2023

8 Duke Street  
Truro  
Cornwall  
TR1 2QE

01872 276 099  
[office@evolvetreets.co.uk](mailto:office@evolvetreets.co.uk)

## TABLE OF CONTENTS

1	INSTRUCTIONS .....	3
2	ARBORICULTURAL IMPACT ASSESSMENT (AIA) REPORT AND TREE PROTECTION INTRODUCTION .....	3
3	METHODOLOGY .....	3
4	SUPPORTING DOCUMENTATION .....	4
5	THE SITE .....	4
6	THE TREES .....	5
7	CONSTRAINTS ANALYSIS & DESIGN CONSIDERATIONS.....	5
8	THE PROPOSAL .....	6
9	POTENTIAL IMPACT OF PROPOSAL ON TREES .....	7
10	TREE PROTECTION PROPOSALS .....	9
11	CONCLUSIONS.....	10
	APPENDIX A Tree Schedule Explanatory Notes .....	12
	APPENDIX B Tree Schedule .....	13
	APPENDIX C Legal Constraints.....	16
	APPENDIX D Relevant Planning Policy .....	18
	APPENDIX E Tree Protection Requirements and Barriers.....	20
	APPENDIX F Specification for Tree Protection Barriers .....	21
	APPENDIX G Tree Protection Barriers Medium Construction Pressure.....	22
	APPENDIX H Tree Protection Barrier Without Bracing.....	23
	APPENDIX I Informative Poster.....	24

## 1 INSTRUCTIONS

- 1.1 Taylor Lewis, on behalf of Retirement Homes, instructed us, Evolve Tree Consultancy, to provide:
- An updated Tree Survey, Constraints Analysis, Tree Constraints Plan.
  - An Arboricultural Impact Assessment (AIA) report and Tree Protection Plan (TPP).
- 1.2 We have since been asked to amend the report in light of further layout changes.
- An updated Tree Survey, Constraints Analysis, Tree Constraints Plan
  - Arboricultural Impact Assessment and Tree Protection Plan.

## 2 ARBORICULTURAL IMPACT ASSESSMENT (AIA) REPORT AND TREE PROTECTION INTRODUCTION

- 2.1 The site contains several trees in the garden associated with Lowen House and along the former hedge boundary north of the boundary wall; these are the key arboricultural features.
- 2.2 The plan presented is an updated AIA & TPP resulting from the re-survey of the trees. I have not been provided with any amended proposals at this stage.

## 3 METHODOLOGY

- 3.1 This survey and analysis accords with British Standard 5837:2012 Trees in relation to design demolition & construction – Recommendations (BS5837). This is the document that the local planning authority will use to assess the proposals.
- 3.2 The trees were inspected using the Visual Tree Assessment method as described by Mattheck and Breloer (The body language of trees, DoE booklet Research for Amenity Trees No. 4, 1994). All trees have been visually surveyed from ground level without climbing, boring or core sampling undertaken. Binoculars were used to assess areas of the crown as appropriate.
- 3.3 The three stages of a Visual Tree Assessment are:
1. Visual inspection of the tree for defect symptoms and overall vitality. If there are no signs of any problems the assessment is concluded.
  2. If a defect is suspected based on the symptoms, the presence or absence of that defect must be confirmed by thorough examination.
  3. If the defect is confirmed, it must be quantified and the strength of the remaining part of the tree evaluated.

- 3.4 It should be noted that a visual tree assessment is visual only (although it is often undertaken with the aid of a probe, a sounding mallet and a pair of binoculars). The quantification and evaluation (stage 3) may be beyond the scope of a visual inspection and require the use of diagnostic decay equipment and/or a separate climbing assessment. It is important to note that even healthy, vigorous and defect free specimens have a natural failure rate.
- 3.5 The baseline data recorded includes; species, stem diameter, branch spread to each of the four cardinal points, height of lowest branch above ground, age class, physiological condition, structural condition, recommendations, estimated remaining contribution in years, qualities based on their arboricultural, landscape and cultural values.
- 3.6 The data are considered to produce comment upon the proposals, make recommendations and to produce a Tree Constraints Plan & or a Tree Protection Plan.

## 4 SUPPORTING DOCUMENTATION

- 4.1 This report and associated plans and findings are based on the documents provided, as listed below:
  - Topographic survey.
  - KWL Architects Drawing Series 4947 Existing and Proposals Plans.
  - KWL Architects Proposed Site Plan – Extent of Red Boundary Planning Drawing 4947-PL06 dated 09.08.2023.
- 4.2 The tree constraints report and plan (previously supplied) include the data collected during the site visit and associated, relevant information regarding statutory protection, designations and planning policy.
- 4.3 This report is to be read alongside Evolve TCP-AIA-TPP Ref: EV-2001-5-C.
- 4.3.1 Further details are presented as Appendix D Statutory Protection and Controls.

## 5 THE SITE

- 5.1 I have restricted my survey to the area adjacent to Lowen House where the previous extensions were proposed. This area comprises several large and mature trees within formal gardens.
- 5.2 Access to the site is from the existing car park provision. The car parking to the east of the trees was recently constructed.
- 5.3 Surrounding land is a mix of residential, retirement complex and agriculture.



Image 1. Aerial view of approximate area of survey.  
©Google Map Data 2023.

## 6 THE TREES

- 6.1 The condition of two of the trees has changed significantly since my last survey. The ash tree T2 was suffering from ash die-back and this has advanced significantly. This tree now has a limited life-span and should be removed as soon as resources allow.
- 6.2 The cypress T9 has continued to decline and should be removed before the risk it presents is realised.
- 6.3 The sweet chestnut T7 has some incipient signs of stress and decline. This species is susceptible to a fungal-like disease (Phytophthora). This tree should be monitored annually to assess if the disease is present.
- 6.4 The condition of the remainder of the trees is reasonable to good.
- 6.5 There has been growth of the trees and the RPAs and other dimensions have been amended accordingly.

## 7 CONSTRAINTS ANALYSIS & DESIGN CONSIDERATIONS

- 7.1 The key constraints posed by the trees are shown on the TCP drawing. Both the above and below ground constraints have the potential to influence the design.
- 7.2 Tree Quality Assessment: The cascade chart, presented as part of Appendix B, is a construct of the BS5837 designed to help describe the characteristics and relative value of trees. It provides guidance enabling an estimate of which trees are important and which trees are not.

- 7.2.1 It does not dictate which trees ought to be retained or removed, merely the weight that should be given to them when balancing competing interests. Certain trees may be of such importance and sensitivity that they justify having a major influence on design. Others may be of little significance that could be removed without adverse impacts.
- 7.2.2 The key trees are identified in the survey schedule presented as Appendix B.
- 7.3 The root protection area (RPA): This is an area (representing a volume of soil) considered necessary to maintain the trees viability. The area represented on the TCP is a minimum recommended by BS5837 and is capped at 707 m<sup>2</sup>.
  - 7.3.1 The shape of the RPA will vary in accordance with site conditions e.g. a road is likely to form a barrier to root growth. Whilst the notional RPA is circular the shape plotted on the TCP may be a polygon to reflect likely barriers to root growth.
  - 7.3.2 Encroachment within the RPA of retained trees will require justification and be supported by a sound rationale from the project arboriculturist.
- 7.4 Tree species: The species will influence a number of factors relevant to design including height (represented by the length of the shade arc), spread (indicated on the TCP), ultimate height and spread (which may be indicated where appropriate), deciduous/evergreen nature, crown density, seasonal nuisance etc.
  - 7.4.1 The proximity of a tree to constructed houses and gardens can be a key factor affecting people's enjoyment of a property.
- 7.5 Age: Mature and over-mature trees are more sensitive to change than young trees. Their inability to adapt to altered soil conditions within or near the RPA means that care is required when designing in these places.
- 7.6 Shade Arc: This is an average pattern of the shade as it passes through the day. It provides an indication of how trees may impede direct sunlight.
  - 7.6.1 Dense shade can be addressed by the siting of dwellings and a reasonable proportion of the garden outside the shade arcs.
  - 7.6.2 Siting buildings within the shade arc can adversely affect the availability of natural daylight to principal living rooms. The internal arrangement of buildings and fenestration design can make significant improvements to daylight availability.
- 7.7 Services: It is prudent to locate new services outside the RPA and crown (allowing for future growth) of retained trees. However, the impact of putting services close to trees will be determined by the sensitivity and/or quality of the trees.

## 8 THE PROPOSAL

8.1 The proposals are to convert the existing care home buildings to apartments and extend to the east as shown in the plan below.

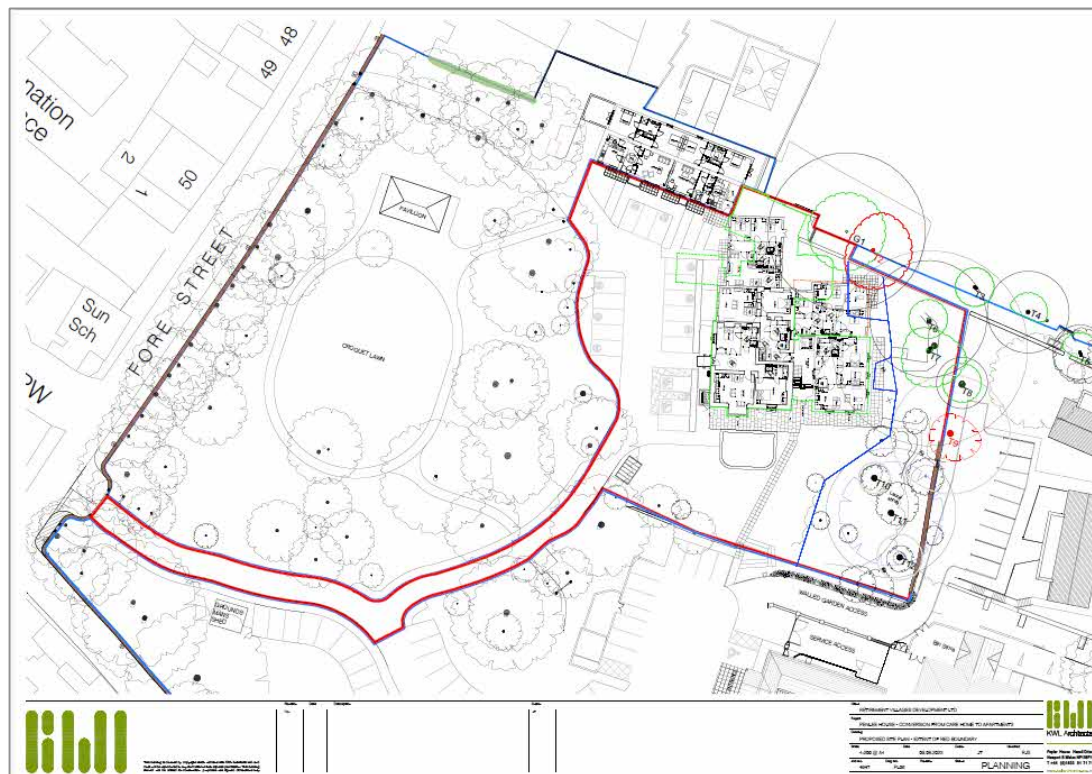

Image 2. KWL Architects Proposed Site Plan – Extent of Red Boundary Planning Drawing 4947-PL06 dated 09.08.2023.  
Extract Not to scale.

## 9 POTENTIAL IMPACT OF PROPOSAL ON TREES

9.1 My assessment focuses on the impacts relevant to planning merits and is guided by the British Standard BS5837 'Trees in relation to design, demolition, and construction – recommendations'.

9.2 Typical considerations include:

Use of land near trees	Construction access	Shading
Proximity to other structures	Statutory Protection	Infrastructure
Mitigation planting	Canopy protection	Design conflicts
Effect on amenity value	Build practicability	Necessary pruning
Removal of structures	Future conflicts	Tree loss

9.3 Arboricultural impacts are a predicted change in condition as a result of an activity related to the project. The importance of an impact is a result of the relationship between the magnitude of a change (positive or negative) and the quality or sensitivity of the feature being affected.

- 9.4 The whole of the area to the east of Lowen House is within the RPA of one tree or another. Consequently, any extensions will be constructed so as to minimise any ground disturbance. This is often achieved with piled foundations or other engineering solution.
- 9.5 Ground protection measures will be installed alongside the construction where they enter the RPAs to provide protection for the soil structure thereby allowing the roots to continue to function.
- 9.6 Though direct shade is not onto the buildings the trees do have some effect on the light access. The exact measurement of this is beyond the scope of this report though there will be little meaningful change from the existing situation. This has not been considered an issue for the residents.
- 9.7 The Magnolia Tree T13: This tree is a twin-stemmed specimen growing from the wall adjacent to the door (Image 3) and, I have been informed, next to a cellar. Concerns have been raised with regards the potential for any damage to be caused by roots to either the wall of the house or the cellar.



Image 3. Magnolia T13.

- 9.7.1 The damage to the wall of the house is unlikely to be affected by tree root growth given the soils are not shrinkable. There may be some potential for minor damage as a result of radial growth of the stem though trees typically deform around the 'harder' object, this is particularly the case with magnolia.



Consequently, I do not believe this presents a risk that warrants action at this stage.

- 9.7.2 The second issue is of root ingress into the wall of the basement. This is possible but unlikely to be significant. Given the tree has been there for many years in very close proximity to this wall, I would have expected some damage to be already evident. Should this become an issue, then tree management, probably removal, should be considered.
- 9.7.3 The potential for managing the tree to reduce the tree is not a realistic solution. There is no direct relationship between root growth and above ground growth so any pruning would have uncertain results at best. It would also reduce the natural form of the tree that provides much of its value.
- 9.8 The proposals will not have any significant impacts on the retained trees. Two trees will be lost but this is due to other factors and will need to be undertaken regardless of any development.
- 9.9 Visual Amenity: The impact on the visual amenity will be moderate but the tree losses are to happen regardless of development.
- 9.10 Sunlight/Daylight Availability (Shading): The TPP indicates the shade arcs for retained trees and demonstrates that the trees will have an effect on the enjoyment of the garden or dwelling.
- 9.11 Build Practicability: The root protection area (RPA) and canopy of the key trees can be protected during development by establishing a Construction Exclusion Zone (CEZ). The CEZ will be protected by way of a tree protection barrier (TPB) as indicated on the TPP.

## 10 TREE PROTECTION PROPOSALS

- 10.1 Based on the information provided to date, this report and TPP provide defined tree protection proposals (related to this design) which can be implemented without further specification.
- 10.2 The TPP defines the position of tree protection fencing which will be erected prior to the commencement of development and thereafter retained until completion. Please refer to requirements and illustrations of tree protection barriers presented as Appendices E to I.
- 10.3 Arboricultural site considerations are presented as Appendix I.

## 11 CONCLUSIONS

- 11.1 The overall arboricultural impacts of the proposed development are low. Consequently, the proposal does not conflict with either local or national planning policies.
- 11.2 We accept that a planning condition be imposed within any future decision notice which requires the measures outlined within the Tree Protection Plan to be implemented as defined.



Tim Scott-Ellis BSc Hons (For), Dip Arb (RFS), F Arbor A, MICFor, MRICS  
Evolve Tree Consultancy

I am a Fellow of the Arboricultural Association, a Chartered Arboriculturist and a Chartered Surveyor. I hold an honours degree in Forestry and the Royal Forestry Society Professional Diploma in Arboriculture. I have been working as a full-time, professional arboriculturist since 1999.



*The authority of this report ceases when any site conditions change or pruning or other works unspecified in the report are carried out to, or affecting, the subject tree(s). The statements made in this report do not consider the effects of extremes of climate, vandalism or accident, whether physical, chemical or fire. Evolve Tree Consultancy cannot accept any liability about these factors, nowhere prescribed work is not carried out in a correct and professional manner in accordance with current good practice.*

*The recommendations within this report remain valid for the period stated for re-inspection or twelve months from the date of the survey.*

*The limit of Evolve Tree Consultancy's indemnity over any matter arising out of this report extends only to the instructing client; Evolve Tree Consultancy cannot be held liable for any third-party claim that arises following or out of this report. This report remains the intellectual property of Evolve Tree Consultancy.*

## APPENDIX A

### Tree Schedule Explanatory Notes

Sequential Tree, Group or Woodland Reference Number.

Name: Scientific name (Common name in brackets).

Height: Recorded in metres by inclinometer in each discrete area and estimated from the measured tree. (lwr crn ht) Lower crown height, the height of the canopy above the ground.

Trunk diameter: Tree stem diameter in millimetres at 1.5 metres above adjacent ground level rounded up to nearest 50 millimetres. For multi-stemmed trees a cumulative diameter is calculated (in accordance with BS 5837:2012 Annex C).

Crown Spread: Measured in metres & taken at four cardinal points (N E S W).

1<sup>st</sup> Sig branch: Existing height in metres above ground level (agl) of the first significant branch with direction of growth (if available).

Life stage	Y	Young	Recently planted or establishing tree.
	SM	Semi-mature	Age less than one-third life completed. Established tree but one that has not reached its potential ultimate height and has significant growth potential.
	EM	Early-mature	One-third to two-thirds life completed. A tree reaching its ultimate potential height, whose growth rate is slowing down but will still increase in stem diameter and crown spread.
	M	Mature	Two thirds plus life completed. Specimen with limited potential for any significant increase in size but with a reasonable life expectancy.
	LM	Late-mature (Over-mature in the BS)	Two-thirds plus life completed and declining. A tree that has passed its optimum growth rate and may require specialist management. These trees may offer significant benefits in terms of nature conservation
	V	Veteran	A tree that shows features of biological, cultural or aesthetic value that are characteristic of, but not exclusive to, individuals surviving beyond the typical age range for the species concerned.

Category: A grade given in accordance with BS 5837:2012 - Tree Categories (see copy of Table 1 from BS 5837:2012 below).

Comments: General observations e.g. collapsing, the presence of any decay and physical defect and including further investigation of suspected defects that require more detailed assessment and potential for wildlife habitat.

Life Expectancy: Estimated remaining contribution in years in terms of amenity (<10, 10+, 20+, 40+).

Physiological condition	G	Good	Tree that appears to be in good condition and healthy without significant defects.
	F	Fair	Tree that appears to be structurally sound but due to minor defects is downgraded from good.
	P	Poor	Tree which shows signs of poor health, in decline and/or with significant defects.
	D	Dead	Tree which is moribund or has died.

Recommendations: Preliminary management recommendations based on the site as surveyed and for any likely pruning likely to be required should any development proceed.

RPA-R (m) - Root Protection Area (RPA) Radius - The radius of an indicative circle of the RPA.

RPA (m<sup>2</sup>) - RPA Area in metres squared.





APPENDIX B  
Tree Schedule

Tree No.	Name (Common & Scientific)	Ht (m)	Stem dia. (mm)	Branch Spread (m)				1 <sup>st</sup> sig branch (m)	Life Stage	Comments	Life Exp (yrs)	Cond	Advice	Cat	RPA R m	RPA A m <sup>2</sup>
				N	E	S	W									
G1	Tilia X europaea (Common Lime)	18(1)	310 600 750	6	6	6	6	3	M	Located on hedge bank. Suckers around stem base. Stem divides below 1.5m. Major deadwood in crown.	40+	Good		A1, 2	12.1 1	461
T2	Fraxinus excelsior (Ash)	20(1)	850	6	6	6	4	2	M	Located on hedge bank. Ivy on tree. Dieback in crown. Low bud/leaf density. In neighbouring property.	40+	Fair	Remove due to ash die-back	U		
T3	Acer pseudoplatanus (Sycamore)	6(0.5)	100 100 100 150 100	3	3	3	3	0	SM	Located on hedge bank. Lapsed coppice. Part of linear group. Ivy on tree.	20+	Fair		C1	3	28
T4	Ilex aquifolium (Holly)	8(3)	300 350 250	3	3	1	3	3	M	Declining. Located on hedge bank.	20+	Fair		B2	6.29	124
T5	Ilex aquifolium (Holly)	8(3)	350	3	3	1	3	3	M	Declining. Located on hedge bank.	20+	Fair		B2	4.2	55
T6	Ginkgo biloba (Maidenhair Tree)	15(1)	750	3	3	3	3	4	M	Stem divides above 1.5m.	40+	Fair		A1, 2	9	255
T7	Castanea sativa (Sweet Chestnut)	18(1)	1250	3	6	6	4	5	M	No significant visible defects but some decline. Stem divides above 1.5m.	40+	Good	Monitor annually to assess condition.	C1, 2	15	707

Tree No.	Name (Common & Scientific)	Ht (m)	Stem dia. (mm)	Branch Spread (m)				1 <sup>st</sup> sig branch (m)	Life Stage	Comments	Life Exp (yrs)	Cond	Advice	Cat	RPA R m	RPA A m <sup>2</sup>
				N	E	S	W									
T8	Thuja plicata (Western Red Cedar)	14(2)	100 150 150 100 150	3	3	3	3	0	EM	Crown lifted to current dimensions. Adjacent to new path & garden.	40+	Fair		A1, 3	3.94	49
T9	Chamaecyparis lawsoniana (Lawson Cypress)	15(3)	800	3	4	4	4	2	M	Low bud/leaf density. Adjacent to new parking. Continued decline as a result of root disturbance	40+	Fair	Remove & replace.	U		
T10	Ornamental maple	6 (2)	240 (2)	2	2	2	2		Y	Crown distorted due to group pressure. Snake bark maple, twin-stemmed.	10+	Fair	No works required.	C1	3	26
T11	Magnolia	13 (3)	830 (SS)	8	8	8	8		M	No obvious or significant defects. Stem divides above 1.5m. Tagged 383.	20+	Good	No works required.	B1	10	312
T12	Lawson Cypress	12 (4)	350 (2)	1	1	1	1		SM	Potentially weak union at 0.5 m agl.	10+	Fair	No works required.	C1	4	55
T13	Magnolia	8 (0.5)	250 300 (2)	4	1	4	5	0.5	EM	Growing adjacent to wall.	40+	Good	No work required.	B1	4	55

Table 1 from BS 5837:2012

Trees in relation to design, demolition & construction – Recommendations. Cascade chart for tree quality assessment

Category and definition	Criteria (including subcategories where appropriate)			Identification on plan
<p>Trees unsuitable for retention (see Note)</p> <p>Category U</p> <p>Those in such a condition that they cannot realistically be retained as living trees in the context of the current land use for longer than 10 years</p>	<p>Trees that have a serious, irremediable, structural defect, such that their early loss is expected due to collapse, including those that will become unviable after removal of other category U trees (e.g. where, for whatever reason, the loss of companion shelter cannot be mitigated by pruning).</p> <p>Trees that are dead or are showing signs of significant, immediate, and irreversible overall decline</p> <p>Trees infected with pathogens of significance to the health and/or safety of other trees nearby, or very low-quality trees suppressing adjacent trees of better quality</p> <p>NOTE Category U trees can have existing or potential conservation value which it might be desirable to preserve.</p>			<p>RED</p> 
	1 Mainly arboricultural qualities	2 Mainly landscape qualities	3 Mainly cultural values, including conservation	
<p>Trees to be considered for retention</p> <p>Category A</p> <p>Trees of high quality with an estimated remaining life expectancy of at least 40 years</p>	<p>Trees that are particularly good examples of their species, especially if rare or unusual; or those that are essential components of groups or formal or semi-formal arboricultural features (e.g. the dominant and/or principal trees within an avenue)</p>	<p>Trees, groups or woodlands of particular visual importance as arboricultural and/or landscape features</p>	<p>Trees, groups or woodlands of significant conservation, historical, commemorative or other value (e.g. veteran trees or wood-pasture)</p>	<p>GREEN</p> 
<p>Category B</p> <p>Trees of moderate quality with an estimated remaining life expectancy of at least 20 years</p>	<p>Trees that might be included in category A, but are downgraded because of impaired condition (e.g. presence of significant though remediable defects, including unsympathetic past management and storm damage), such that they are unlikely to be suitable for retention for beyond 40 years; or trees lacking the special quality necessary to merit the category A designation</p>	<p>Trees present in numbers, usually growing as groups or woodlands, such that they attract a higher collective rating than they might as individuals; or trees occurring as collectives but situated so as to make little visual contribution to the wider locality</p>	<p>Trees with material conservation or other cultural value</p>	<p>BLUE</p> 
<p>Category C</p> <p>Trees of low quality with an estimated remaining life expectancy of at least 10 years, or young trees with a stem diameter below 150 mm</p>	<p>Unremarkable trees of very limited merit or such impaired condition that they do not qualify in higher categories</p>	<p>Trees present in groups or woodlands, but without this conferring on them significantly greater collective landscape value; and/or trees offering low or only temporary/transient landscape benefits</p>	<p>Trees with no material conservation or other cultural value</p>	<p>GREY</p> 

## APPENDIX C Legal Constraints

### Trees outside the site or property

Landowners and managers have a duty of care not to damage trees on the neighbouring land. The common causes of damage (root damage, compaction, physical damage, and inexperienced pruning) must be avoided through good planning and site management.

However, branches and roots from trees on adjacent properties that extend over boundaries can be pruned back to the boundary line without the permission of the owners. However, the branch material belongs to the tree owner and should be returned where appropriate.

### Statutory wildlife obligations

The Wildlife and Countryside Act 1981 as amended by the Countryside and Rights of Way Act 2000 provides statutory protection to birds, bats and other species that inhabit trees. All wild birds are protected by law under the Wildlife & Countryside Act 1981, and it is an offence to disturb, injure or kill a nesting bird intentionally or to take damage or destroy an occupied nest or egg. If nesting birds are discovered works on the trees should be deferred until the nests are abandoned. Care should be taken during any felling operation, or surgery works to trees to avoid damage or disturbance to birds during the nesting season.

### Tree Preservation Orders and Conservation Areas

Wilfully cutting, uprooting, damaging or destroying a protected tree without the council's permission is a criminal offence.

Exceptions are:

Cutting down a tree when it is already dead,

Cutting down a tree that presents "an immediate risk of serious harm",

Pruning part of a tree that presents "an immediate risk of serious harm",

Removing dead branches from a living tree,

Preventing or controlling a "legal nuisance",

When requested by an organisation listed in the council's regulations,

When it is in the interests of national security,

Where the tree is a fruit tree being pruned in accordance with good horticultural practice, or where the tree is in a commercial orchard,

Cutting down trees in accordance with a grant or felling licence obtained from the Forestry Commission,

Where the tree is directly obstructing development for which full planning permission has been granted (not including permitted development).

Important: Exceptions for tree work relating to planning permission and permitted development from the Planning Practice Guidance 15 April 2015 paragraph 36-083-20150415.

Under the heading "Is there an exception for tree work relating to planning permission and permitted development?", of the PPG states:

"The authority's consent is not required for carrying out work on trees subject to an Order so far as such work is necessary to implement a full planning permission. For example, the Order is overridden if a tree has to be removed to make way for a new building for which planning permission has been granted.

Conditions or information attached to the permission may clarify what work is exempt.

However, the authority's consent is required for works on trees subject to an Order if:

development under a planning permission has not been commenced within the relevant time limit (i.e. the permission has 'expired');

Only outline planning permission has been granted; and



it is not necessary to carry out works on protected trees in order to implement a full planning permission.”

Extensive advice can be found at [www.gov.uk](http://www.gov.uk)

#### Forestry Commission Felling licence

In any calendar quarter\*, you may fell up to 5 cubic metres on your property without a licence if no more than two cubic metres are sold. Contact your local Forestry Commission office if you are not certain whether these exemptions apply.

\*1 Jan to 31 March, 1 April to 30 June, 1 July to 30 September and 1 October 31 December

Exemptions: Certain types of felling do not need permission from the Forestry Commission. The Forestry Act 1967, as amended, and related regulations give these exceptions in full. The main categories are listed below:

Lopping and topping (which usually includes tree surgery, pruning and pollarding).

Felling included in an approved dedication plan.

Felling fruit trees, or trees growing in a garden, orchard, churchyard or designated public open space (e.g. under the Commons Act 1899).

Felling trees which, when measured at the height of 1.3 metres from the ground:

have a diameter of 8 centimetres or less; or if thinnings have a diameter of 10 centimetres or less; or

if coppice (i.e. managed by cutting to promote multi-stemmed growth arising at or near ground level) or underwood, have a diameter of 15 centimetres or less.

Felling trees immediately required for carrying out development authorised by planning permission (granted under the Town and Country Planning Act 1990) or for work carried out by certain providers of gas, electricity and water services and which is essential for the provision of these services.

Felling necessary for the prevention of danger or the prevention or abatement of a nuisance (e.g. which may involve the threat of danger to a third party). This exemption will only apply if there is a real rather than a perceived danger. We may be able to give you advice that would minimise the danger without felling the trees. We strongly recommend that you contact us if you are considering felling a tree or trees in these circumstances. You may be prosecuted for illegal felling if it is shown that the tree did not present a real or immediate danger.

Felling necessary to prevent the spread of a quarantine pest or disease and done in accordance with a notice served by a Forestry Commission Plant Health Officer (under the Plant Health (Forestry) (Great Britain) Order 1993, as amended).

The felling is done in compliance with any obligation imposed by or under an Act of Parliament.

More advice can be found at: <https://www.gov.uk/guidance/tree-felling-licence-when-you-need-to-apply>

#### The Hedgerow Regulations 1997

The hedgerow regulations do not apply to the boundary of a domestic curtilage but will affect those hedgerows that border land used for keeping horses or agriculture. The Hedgerows Regulations 1997 make it an offence to remove most countryside hedges without first giving the local planning authority 42 days' notice.

## APPENDIX D Relevant Planning Policy

### National Planning Policy Framework

Paragraph 131. Trees make an important contribution to the character and quality of urban environments and can also help mitigate and adapt to climate change. Planning policies and decisions should ensure that new streets are tree-lined <sup>50</sup>, that opportunities are taken to incorporate trees elsewhere in developments (such as parks and community orchards), that appropriate measures are in place to secure the long-term maintenance of newly-planted trees, and that existing trees are retained wherever possible. Applicants and local planning authorities should work with highways officers and tree officers to ensure that the right trees are planted in the right places, and solutions are found that are compatible with highways standards and the needs of different users.

Paragraph 174. Planning policies and decisions should contribute to and enhance the natural and local environment by:

- (a) protecting and enhancing valued landscapes, sites of biodiversity or geological value and soils (in a manner commensurate with their statutory status or identified quality in the development plan);
- (b) recognising the intrinsic character and beauty of the countryside, and the wider benefits from natural capital and ecosystem services – including the economic and other benefits of the best and most versatile agricultural land, and of trees and woodland;

Paragraph 180. When determining planning applications, local planning authorities should apply the following principles:

- (a) if significant harm to biodiversity resulting from a development cannot be avoided (through locating on an alternative site with less harmful impacts), adequately mitigated, or, as a last resort, compensated for, then planning permission should be refused;
- (c) development resulting in the loss or deterioration of irreplaceable habitats (such as ancient woodland and ancient or veteran trees) should be refused, unless there are wholly exceptional reasons <sup>63</sup> and a suitable compensation strategy exists.

### Cornwall Local Plan

This sets out local planning policy. It includes the following relevant policies:

Policy 12: Design – Development must ensure Cornwall’s enduring distinctiveness and maintain and enhance its distinctive natural and historic character.

Policy 22: European Protected Sites – mitigation of recreational impacts from development.

Policy 23: Natural environment. Development proposals will need to sustain local distinctiveness and character and protect and where possible enhance Cornwall’s natural environment and assets according to their international, national, and local significance.

### Cornwall Council Climate Emergency Development Plan Document February 2023

In order to achieve the vision of achieving carbon neutrality by 2030 policies have been developed to:

Decarbonise lifestyles via the reduction of emissions from buildings, travel and leisure

Create resilient communities and nature

Create environmental growth, develop and reinforce natural systems to protect and enhance the environment

Rebalance the need to travel and how people move around and work

Ensure the health and wellbeing of residents

Embed practice and standards to make buildings and places more efficient

Reduce use of material and waste

Develop a whole system approach.

The policies most relevant to trees and development are

#### Policy G1 Green Infrastructure Design and Maintenance

Green infrastructure should be central to the design of schemes, ensuring permeability of the site for wildlife and people and creating a multi-functional; network of spaces and uses. All developments should be planned around the protection and enhancement of nature.

#### Policy G2 Biodiversity Net Gain

All development proposals (except those defined as exempt in secondary legislation) must achieve a minimum of 10% Biodiversity Net Gain (or any higher percentage mandated by national policy/legislation) over the pre-development site value as measured by the latest version of the DEFRA Biodiversity Metric.

Policy G3 Canopy

All major development should provide, through the retention of existing and/or the establishment of new, canopy coverage equal to at least 15% of the site area (excluding areas of the site that are priority habitat types) in accordance with a Cornwall Council approved calculator or metric.

Further details of these policies can be found in the Cornwall Council Climate Emergency Development Plan Document February 2023 available on the Cornwall Council website.

#### Cornwall Council Planning for Biodiversity Guide

The guide sits below the Local Plan and provides additional information to guide decisions relying on policies 22 and 23.

Paragraph 10.7.3 states that "Buffering for hedges suggests that for residential developments that an absolute minimum buffer of 2-metre either side of the hedge is required. For industrial and solar farm developments a 5-metre buffer is an absolute minimum. Where woodland is present a 10-metre buffer is absolute minimum."

## APPENDIX E Tree Protection Requirements and Barriers

No equipment, machinery or materials shall be brought onto the site for the purposes of the development until fencing has been erected in accordance with the plans and particulars which shall have been previously approved by the local planning authority in writing.

The areas forming the Construction Exclusion Zone are to be protected by Tree Protection Barriers as per the recommendations in BS 5837:2012 (Figure 2) or as specified below at Appendix I.

This fencing is to be erected before any work commences on site and is to remain in place undamaged for the duration of all work or each phase. It will only to be removed once all work is completed and if required by planning condition, with the formal consent of the local planning authority.

If the fencing be broken or removed during the course of carrying out the development, it shall be promptly repaired or replaced to the satisfaction of the local planning authority.

Within any area fenced in accordance with this condition, nothing shall be stored, placed, or disposed of on the above or below ground, the ground level shall not be altered, no excavations shall be made, nor shall any fires be lit, without the prior written consent of the local planning authority.

Other than works detailed within this method statement or approved in writing by the local planning authority, no works at all (including storage or dumping of materials) shall take place within the exclusion zones defined by the protective fencing.

The fencing is to carry waterproof warning notices denying access within the RPA. The following signs or similar will be attached to the fence panels.



## APPENDIX F Specification for Tree Protection Barriers

Below is the fencing specification reproduced from BS 5837:2012 Trees in relation to design, demolition, and construction – Recommendations.

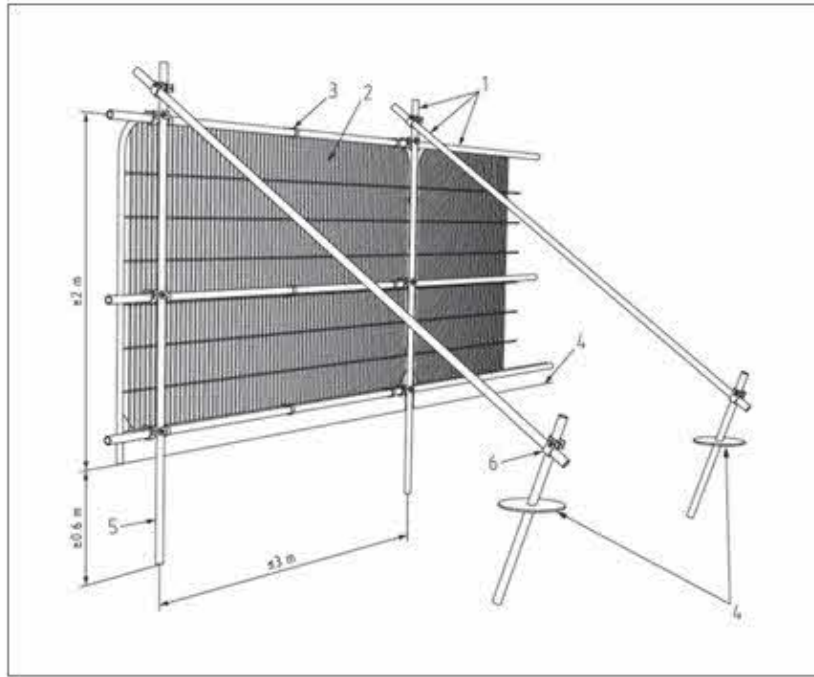

### Key

- 1 Standard scaffold poles.
- 2 Heavy gauge 2 m tall, galvanized tube and welded mesh infill panels.
- 3 Panels secured to uprights and cross-members with wire ties.
- 4 Ground level.
- 5 Uprights driven into the ground until secure (minimum depth 0.6 m).
- 6 Standard scaffold clamps.



## APPENDIX G Tree Protection Barriers Medium Construction Pressure

Tree Protection Barriers (derived & amended from BS5837:2012 Figure 2) where there is insufficient space to install bracing. Examples of configurations for steel mesh perimeter fencing systems are given in BS 1722-18

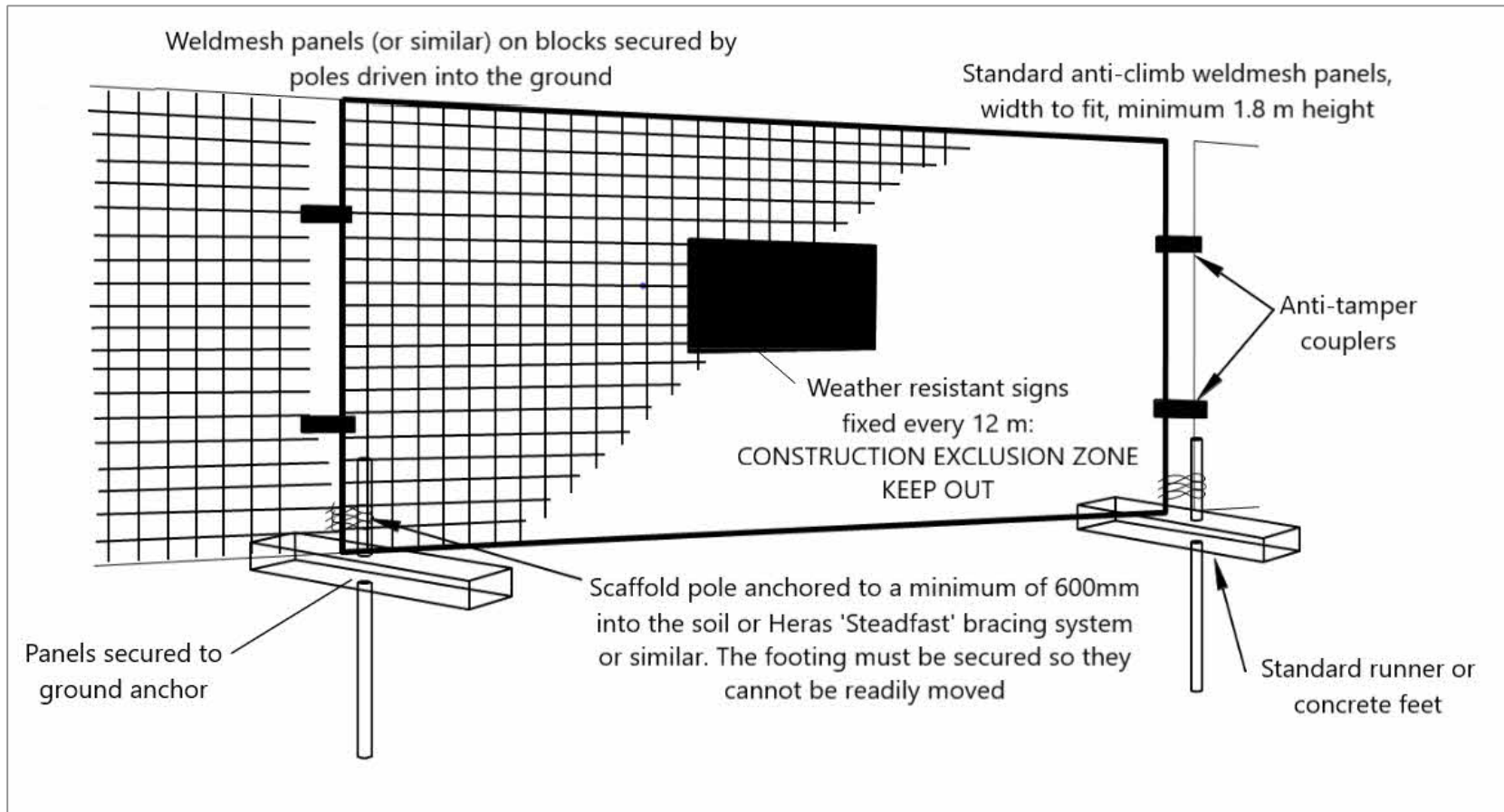

APPENDIX H Tree Protection Barrier Without Bracing



## APPENDIX I Informative Poster

### Arboricultural Site Considerations – To be displayed in a prominent place.

Tree Protective Barriers must be regarded as sacrosanct and must not be removed or altered without prior consultation with either the Local Planning Authority (LPA) or the arboricultural consultant responsible for the site supervision.

Ground protection must not be lifted or removed without prior consultation with either the LPA or the arboricultural consultant responsible for the site supervision.

Damage caused to protective fencing or ground protection must be reported to the site supervisor immediately to ensure efficient repair.

No materials, chemicals, machinery, or vehicles must be stored within the Construction Exclusion Zone as defined on the Tree Protection Plan (TPP) and identified on site by fencing and above ground root protection.

No materials must be rested against a tree's trunk or machinery chained to it.

No pruning of trees may be undertaken by anyone other than an arborist, and all work must be approved by the supervising arboricultural consultant.

Any physical damage caused to a tree retained on site must be reported to the site manager so remedial work can be undertaken without delay.

Builder's sand, which contains salt, must not be used to back fill excavation within or in close proximity to tree roots, as this can have a toxic affect. Sharp sand can be used instead.

Material that will contaminate the soil, e.g. concrete mixings, diesel oil and vehicle washings, must not be discharged within 10 metres of a tree stem.

Fires must not be lit in a position where their flames can extend to within 5 m of foliage, branches, or trunk. This will depend on the size of the fire and wind direction.

Notice boards, telephone cables or other services must not be attached to any part of a tree.



Evolve Tree Consultancy  
8 Duke Street  
Truro  
Cornwall  
TR1 2QE  
01872 276 099