

proposed front porch, 5 chiltern villas, tring
existing plan and elevations

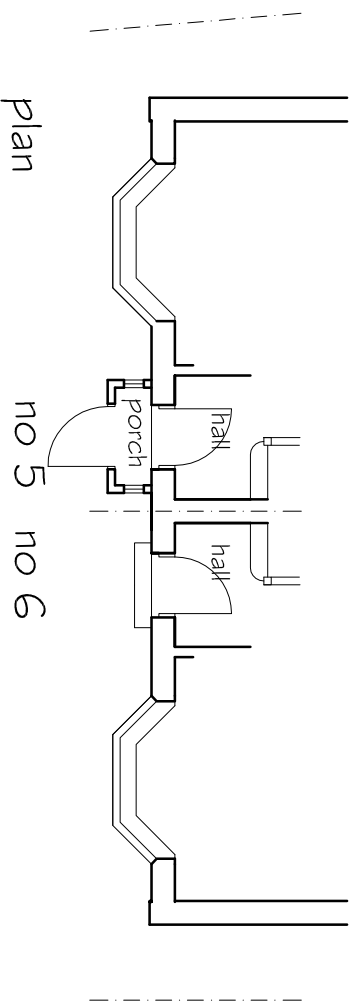
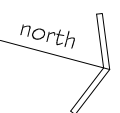
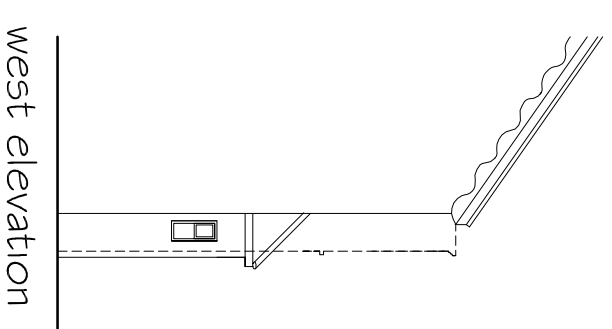
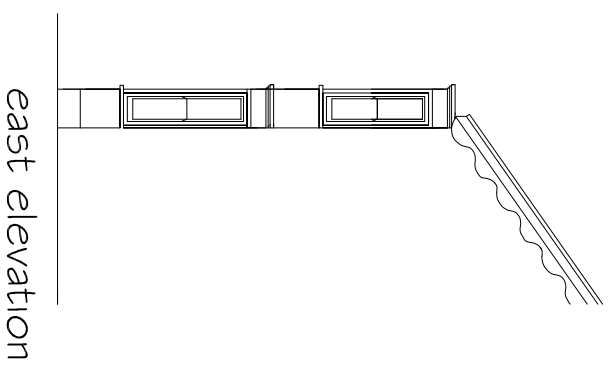
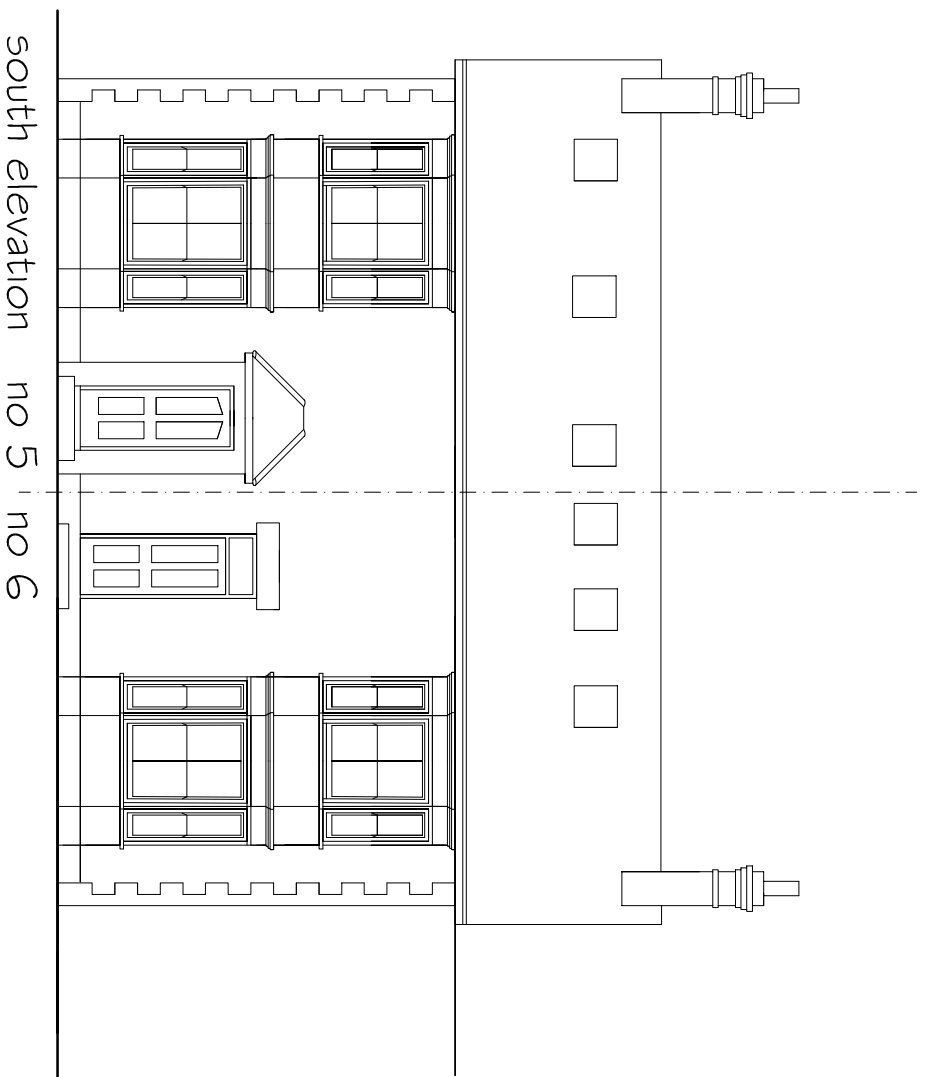

28 Park Road, Tring, Herts, HP23 6BN

Telephone 07964852192

Richard Onslow
A r c h i t e c t

Scale

Date

Drawing no.

1:100 @ A3

October 2023

115.1