

86 Lamberts Field, GL54 2EH
1/7



5.12.2018

Art.Nr. 4015850

Groundplan - Grundplan - Plan de masse - Planimetria - Plattegrond - Põhiplaan

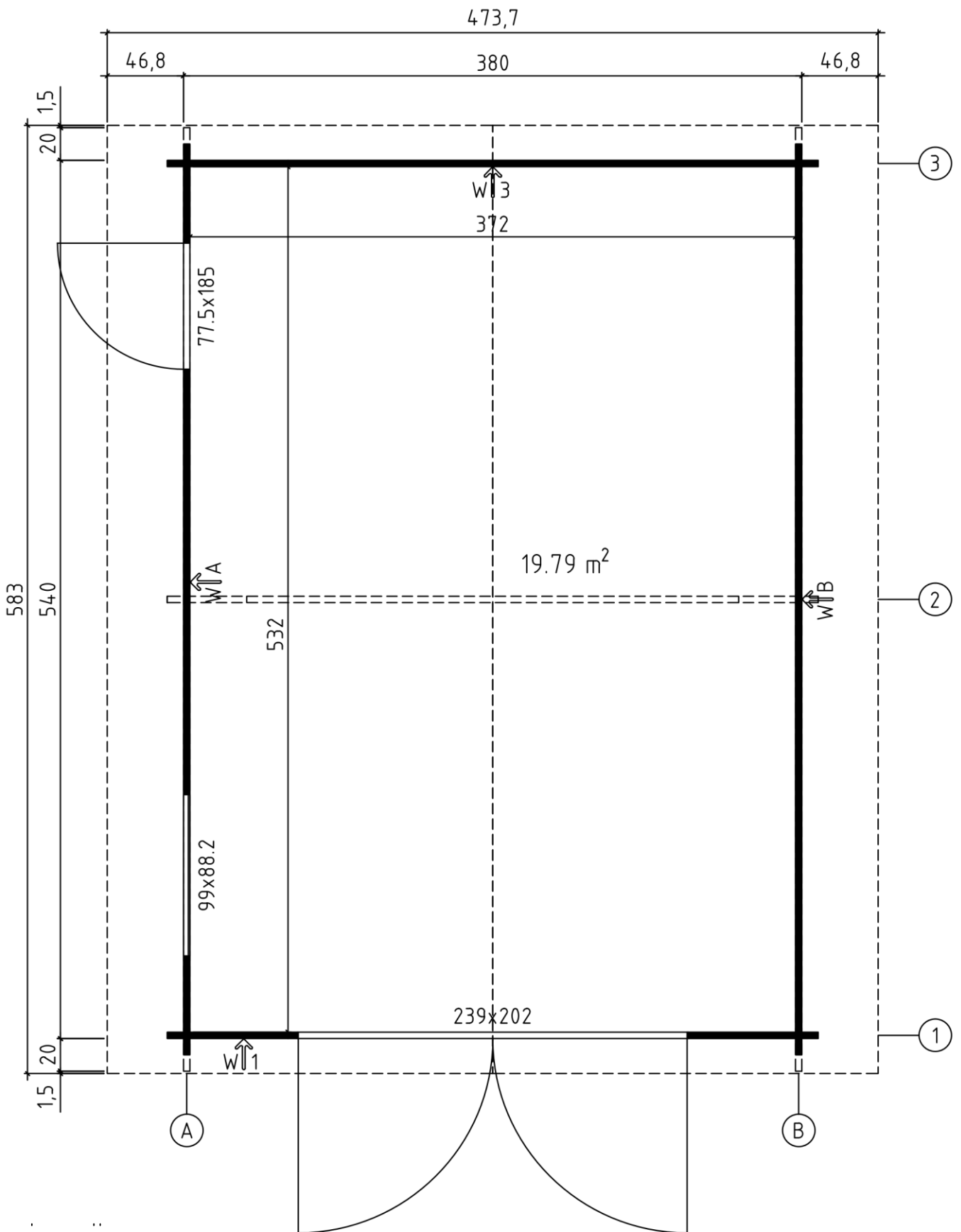

Products Details & Specification

Osland Yarik 540

- Footprint: 3.8m x 5.4m
- Wall Thickness: 40mm
- Side Wall Height: 2.11m
- Ridge Height: 2.74m
- 2 x Door
- 1 x Window

• Roofing Felt is Included

- Can be Built in Reverse
- Optional:
 - Shed Felt
 - Felt Shingles
 - Roof Insulation

Osland Yarik 540: The classic Yarik 540 by Osland is the ideal garage for parking your car, or motorbikes and bicycles, but also a great storage solution for many bulky garden items such as lawnmowers, gardening tools and soil, fertiliser, pet supplies or garden furniture. The garage is built with built from 40mm interlocking timbers with wind-tight chalet connection, and the vehicle door is constructed from solid wood. The back door will provide easy pedestrian access, and it's half glazed, which alongside the large window, will provide the cabin with natural light. The Yarik boasts a classic design with a traditional apex roof and a diamond finial. It will be an attractive addition to your drive and will match any garden. It offers an excellent alternative to a brick-built garage at a fraction of the cost. Please note that the Osland Yarik 540 Garage comes untreated.

North European Spruce Construction: Slowly Grown, High-Quality Machined Timber

Product Downloads

*Delivery & Payment

Reviews ★★★★★

Osland Yarik 540

- Footprint: 3.8m x 5.4m
- Wall Thickness: 40mm
- Side Wall Height: 2.11m
- Ridge Height: 2.74m
- Roof Boards: 15mm
- 1 x Door (Garage - TA+28 - Solid Wood Classic): 2390mm W x 2020mm H
- 1 x Door (Single - SGA+28 - Single Glazed Action): 775mm W x 1850mm H
- 1 x Window (Single & Open Inward- SGA - Single Glazed Action): 990mm W x 882mm H
- Floor Area: 19.8m²
- Roof Area: 29m²
- Slope Angle: 19°
- Overhang Front (door wall) and Rear wall: 20cm
- Both Long Sides: 47cm
- Cubic Volume: 47.9m³
- Delivered in 1 x Package:
- Package Dimensions: 630cm x 120cm x 60cm
- Package Weight: 1255kg
- Does Not Include Floor

Art.Nr. 4015850

Roof plan - Dach-plan - Plan du toit - Piano del tetto - Dak plattegrond - Katuseplan

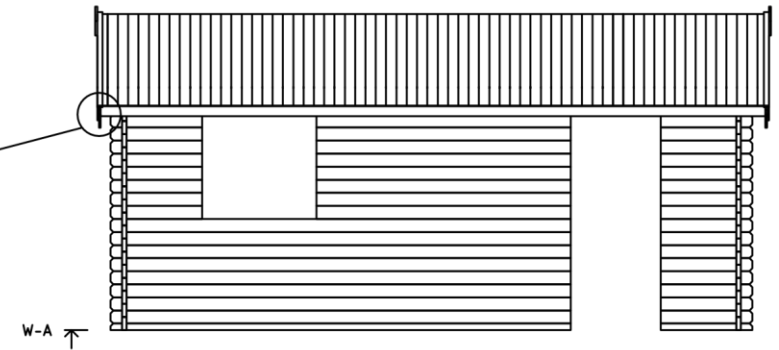
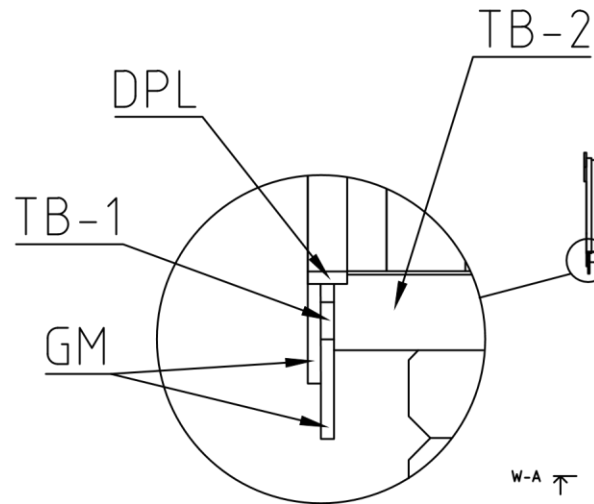
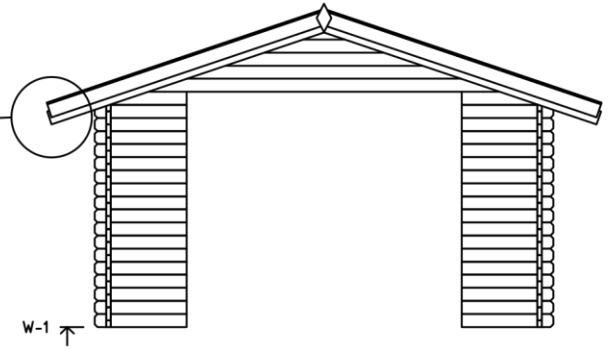
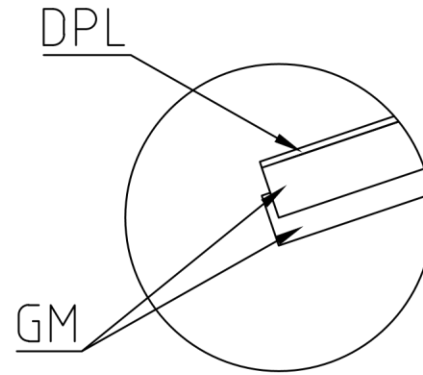
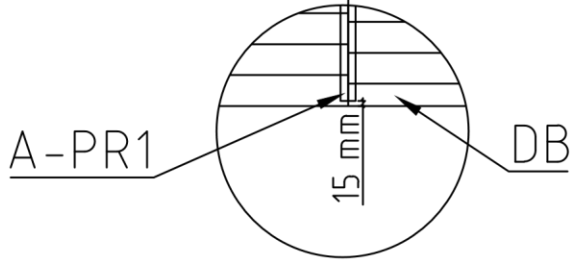
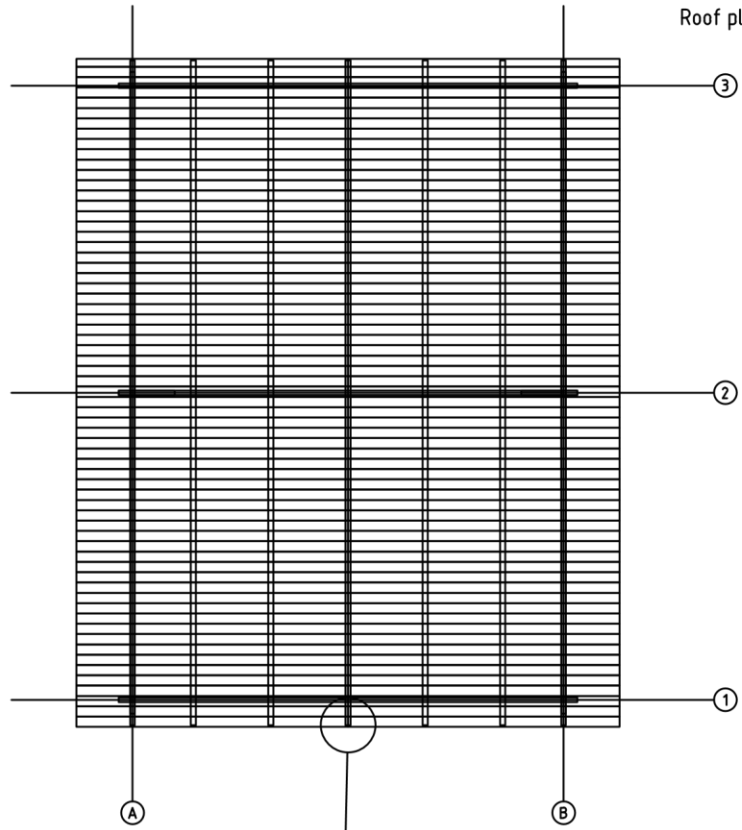

Art.Nr. 4015850

23









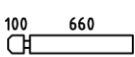

24

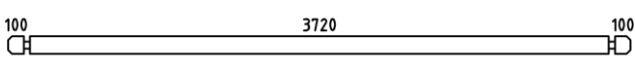
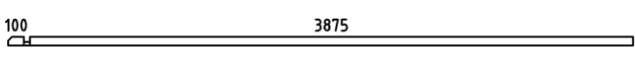
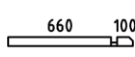
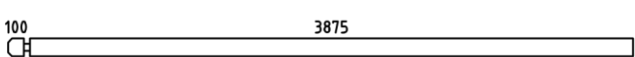
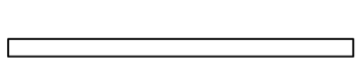
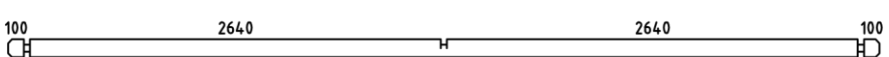

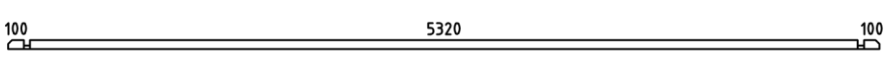
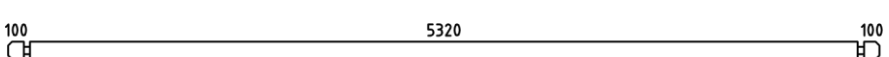
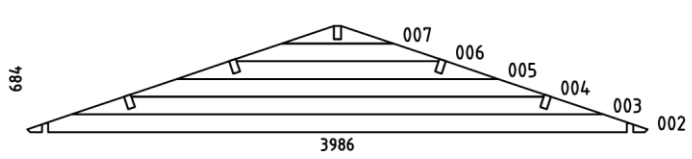
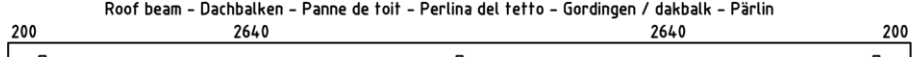
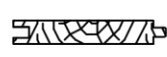



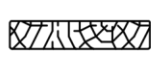

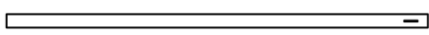
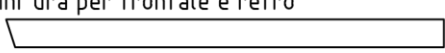

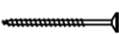

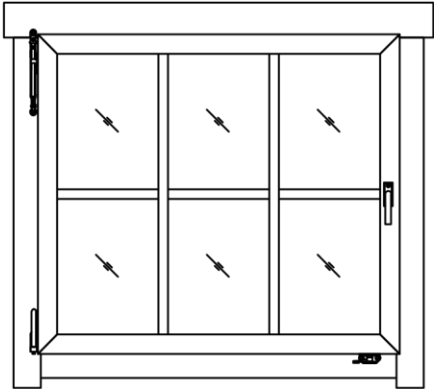
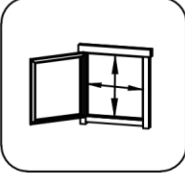

007

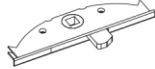
006



Pos	05 12 2018	Pece . s - S-uck. s-e - L s-e des pièces - E.ener - S-uck. s- - uk-abe. 6/7	Q	P (mm)	L (mm)
001			60	40x114	800
008			2	40x114	490
009			18	40x114	4000
010			1	40x57	4015
011			1	40x57	800
012			8	40x114	4015
013			8	40x114	2217
014			2	40x114	5600
015			2	40x120	5800
016			1	40x57	5600
017			16	40x114	5600
W1-1 W2-1 W3-1			1 1 1		
A-PR1	Roof beam - Dachbalken - Panne de toit - Perlina del tetto - Gordingen / dakbalk - Pärilin 		5	44x140	5800
DB	Roof boards - Dachbretter - Voliges - Perlina per tetto - Dakhout - Katuselaud 		130	90x15	2500
DPL	Roofing felt fillet - Dachpappenleiste - Baguette de fixation du feutre bitumeux - Asse per fissaggio guaina bituminosa - Afdekljst asfaltpapier - Katusepapiliist 		4	15x45	2550
DPP-1	Roofing felt (strip) - Dachpappe (bahnen) - Feutre bitumeux (bande) - Cartone catramato - Asfaltpapier (baan) - Katusepapp 		6		5900
TB-1	Gable moulding - Giebelleiste - Planche de rive - Finitura per frontale e retro del tetto - Gevellijst - Viululaud 		4	15x45	2550
TB-2	Fascia board - Traufbrett - Bandeau de toit - Finitura lati tetto - Gevellijst - Räästalaud 		4	15x90	2900
DRV-1	Roof edge reinforcement - Dachrandverstärkung - Corniere de renfort de bord de toit - Rinforzo x tetto - Dakrand versterking - Räästatugevdus 		4	28x34	2900
KFS-1	Storm protector - Sturmleiste - Latte anti-tempete - Protezione anti vento - Stormverankering / beveiliging - Tormikinnitusliist 		4	22x45	2050
	Gable moulding - Giebelleiste - Planche de rive - Finitura per frontale e retro del tetto - Gevellijst - Viululaud 		8	15x120	2550

Pos	05 12 2018	Pece . s' - S-ucx. s'e - L s'e des pièces - E.emepe - S-ucx. ,s' - П-к-abe. Art.Nr. 4015850	7/7	Q	P (mm)	L (mm)
I HS9		Screw for gable moulding - Schrauben für giebelleiste - Vis pour fixation planche de rive - Vite per fissare finiture davanti e dietro del tetto - Schroef voor gevelijst - Kruvi viilulauale		64	3.5x50	

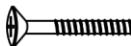
Pos	19.12.2017	Piece list - Spisok, s'pe - Liste des pièces - E.ener - Spisok, s'pe - Spisokabe. 990x882 AK.1.106 SSV.j SGA	1/1	Q	P (mm)	L (mm)
		<p>Glass size - Glasgröße - Taille de la vitre - Misura del vetro - Glas afmeting - Klaasi mõõt: 846x738 mm</p>   <p>890x782 mm</p>				
1		Georgian bars - Sprossen - Croisillons - La griglia georgiana - Raamverdeling - Petteliistud		1	15x25	880
2		Georgian bars - Sprossen - Croisillons - La griglia georgiana - Raamverdeling - Petteliistud		2	15x25	757
FS1		Window handle fittings - Fenstergriff - Poignée de fenetre - Maniglia c/ferramenta - Raamhendel -/grendel -/klink - Aknalink		1		
FSL		Window closer - Fenstergriff - Système de fermeture pour fenêtre - Raamslotje - Akna sulguri südamik		1		
FSA		Window closer striker - Gegenstück für Fenstergriff - Entrebâilleur de fenêtre - Raam sluitplaatje - Akna luku vastus		1		
NA1		Tilt & turn window set - Dreh-Kipp-Beschlag für Fenster - Ensemble de fenêtres oscillo-battantes - Insieme per il fermo dell'oscillazione del battente della finestra - Draaikiep raamsetje - Kald-pöördsuluse komplekt		1		
NA2		Tilt & turn window set - Dreh-Kipp-Beschlag für Fenster - Ensemble de fenêtres oscillo-battantes - Insieme per il fermo dell'oscillazione del battente della finestra - Draaikiep raamsetje - Kald-pöördsuluse komplekt		1		
NA3		Tilt & turn window set - Dreh-Kipp-Beschlag für Fenster - Ensemble de fenêtres oscillo-battantes - Insieme per il fermo dell'oscillazione del battente della finestra - Draaikiep raamsetje - Kald-pöördsuluse komplekt		1		
NA4		Tilt & turn window set - Dreh-Kipp-Beschlag für Fenster - Ensemble de fenêtres oscillo-battantes - Insieme per il fermo dell'oscillazione del battente della finestra - Draaikiep raamsetje - Kald-pöördsuluse komplekt		1		
NA5		Tilt & turn window set - Dreh-Kipp-Beschlag für Fenster - Ensemble de fenêtres oscillo-battantes - Insieme per il fermo dell'oscillazione del battente della finestra - Draaikiep raamsetje - Kald-pöördsuluse komplekt		1		
NA6		Tilt & turn window set - Dreh-Kipp-Beschlag für Fenster - Ensemble de fenêtres oscillo-battantes - Insieme per il fermo dell'oscillazione del battente della finestra - Draaikiep raamsetje - Kald-pöördsuluse komplekt		1		
FSP		Bolt for window handle fittings - Bolzen für fenstergriff beschlag - Vis pour fixation poignée de fenetre - Bullone x apertura manuale finestra - Schroef voor raamhendel - Akna käändeme pelt		2		

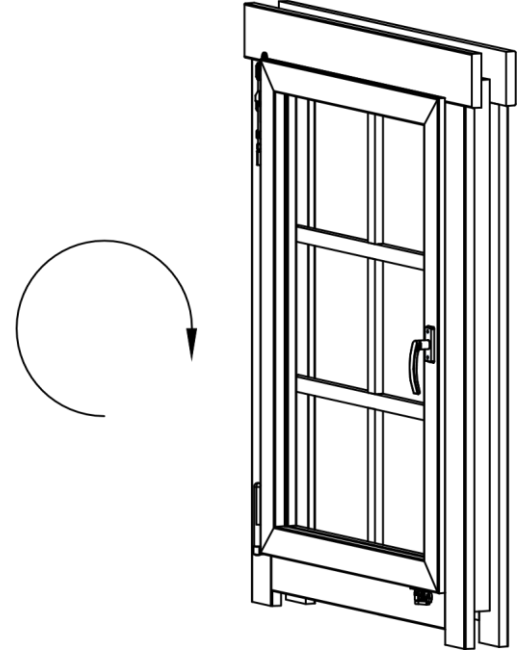

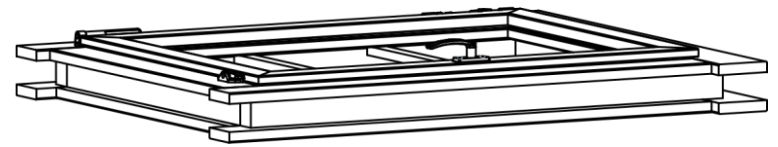
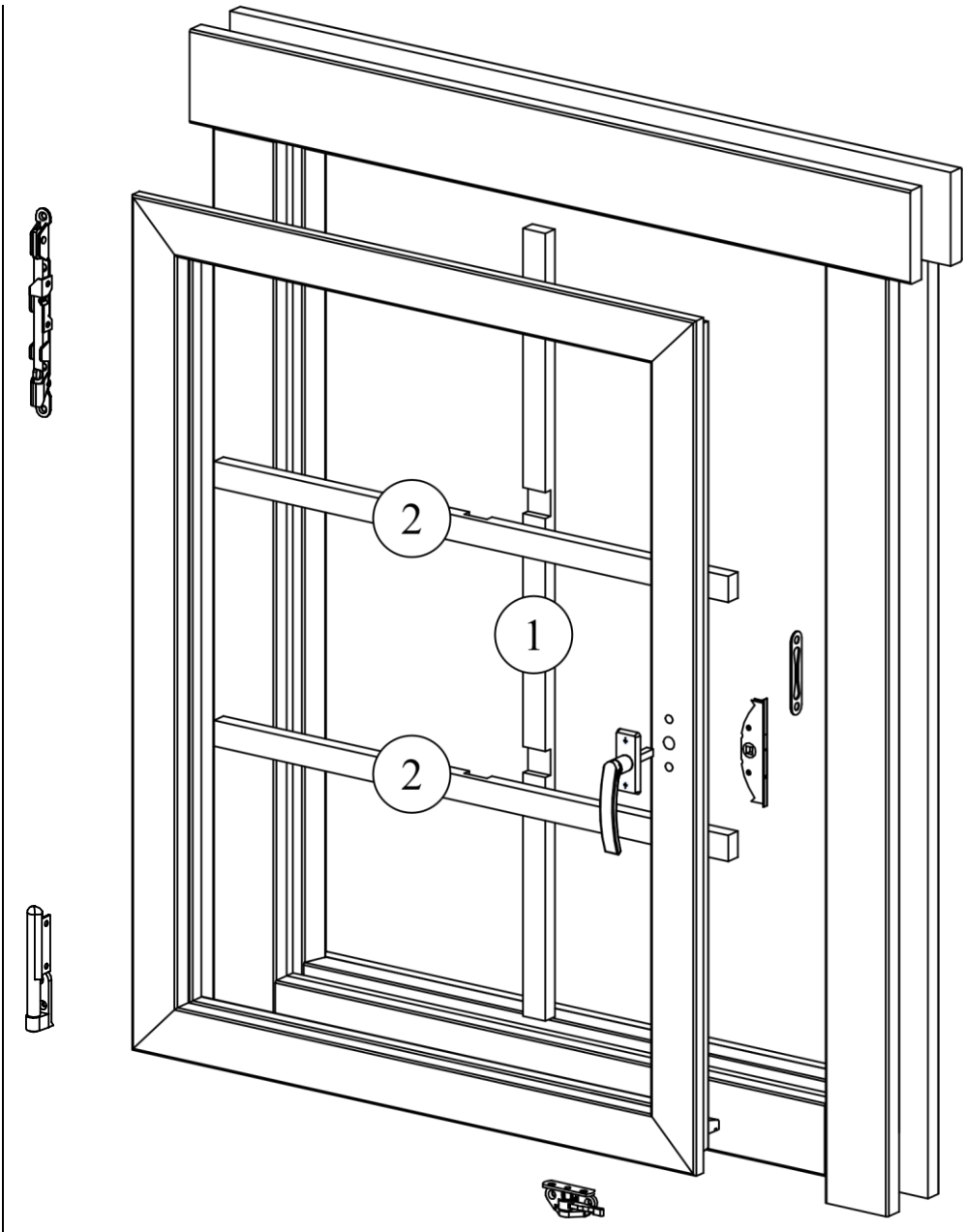

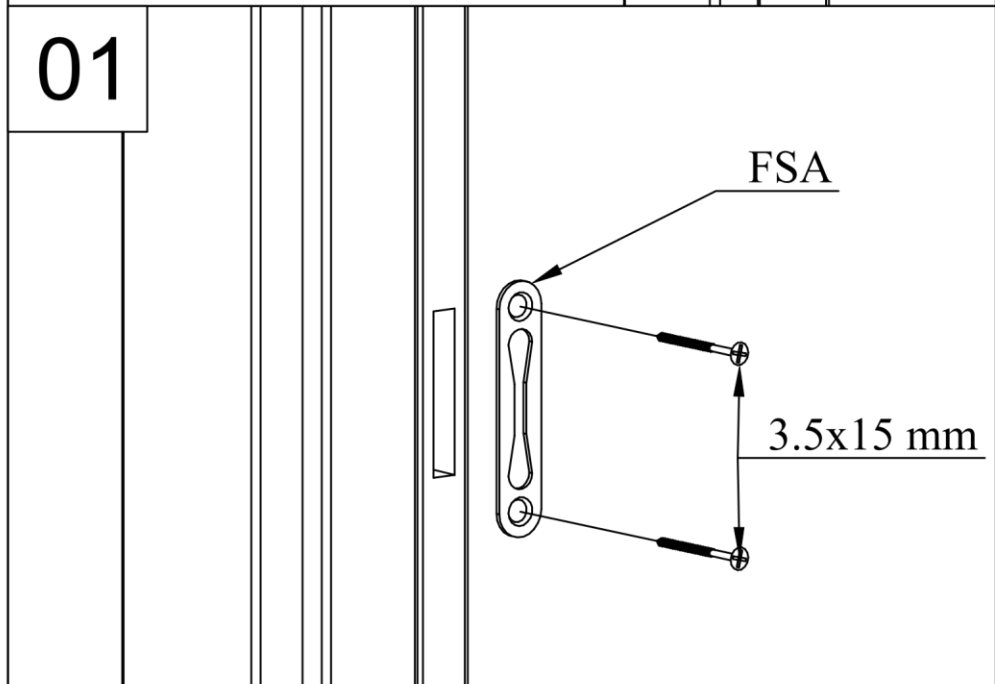
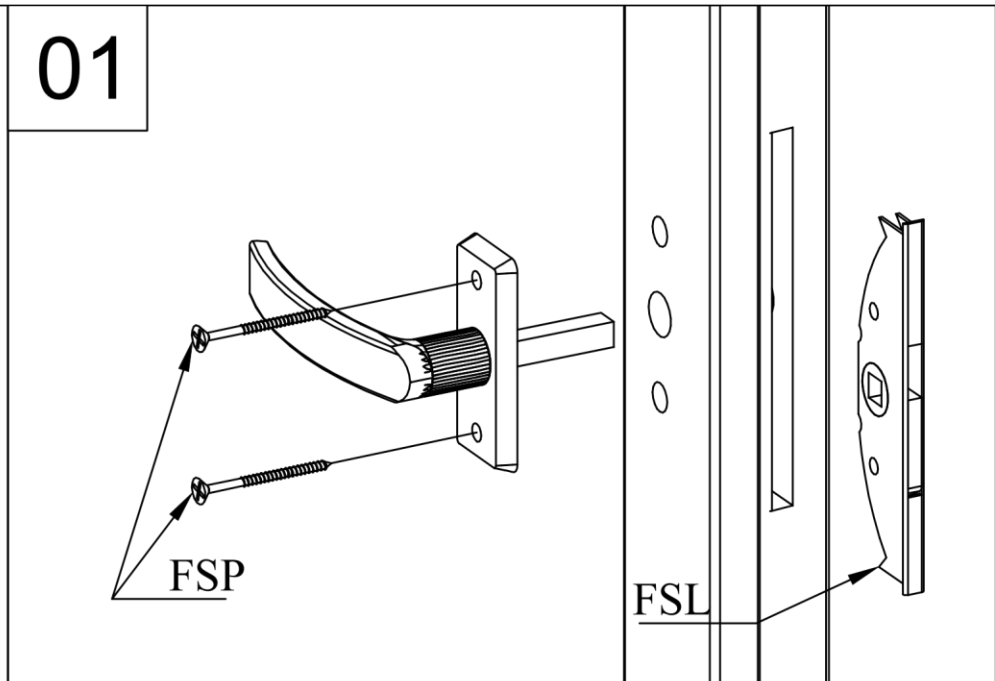
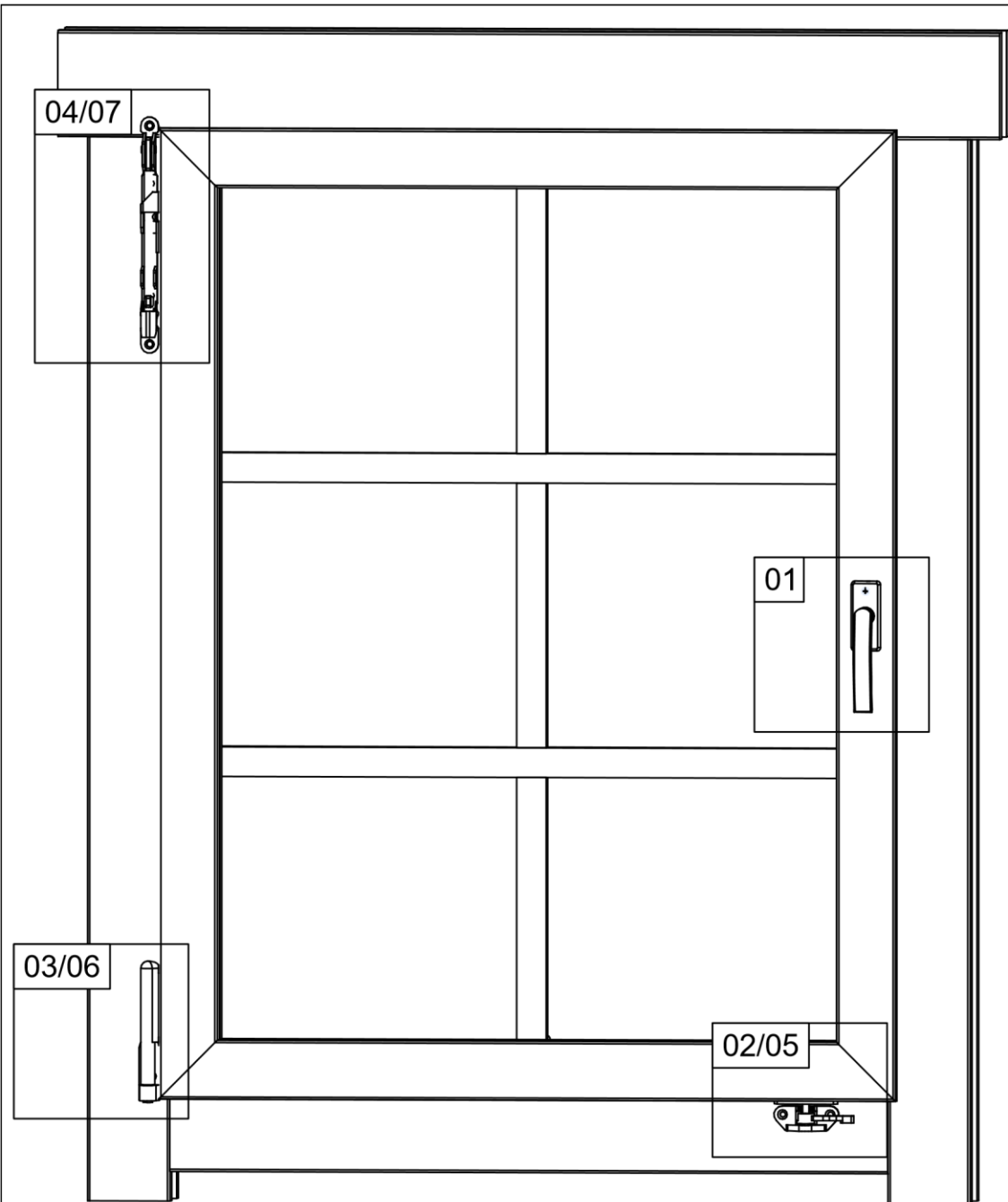

02

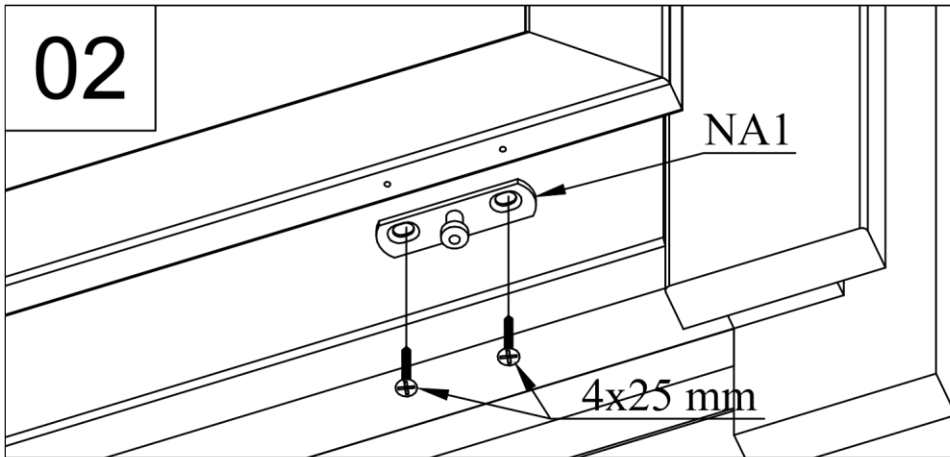

05

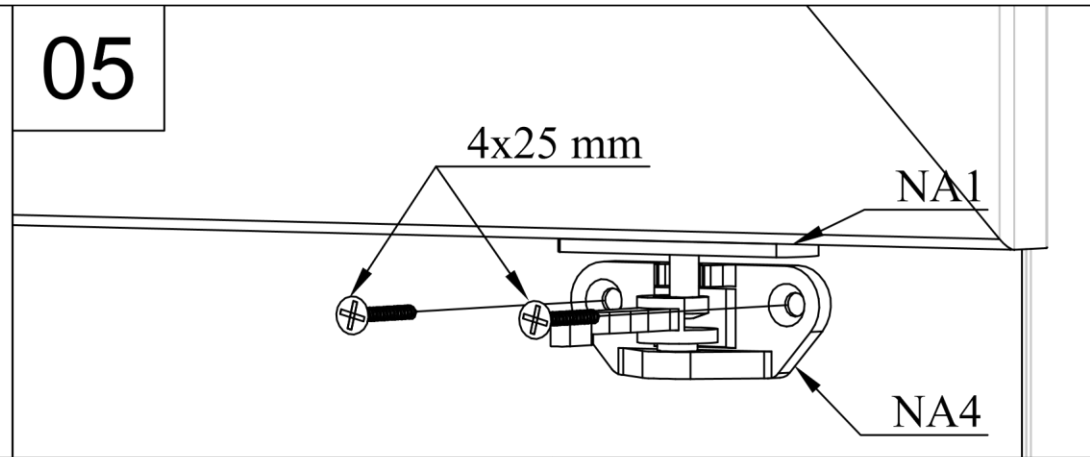

03

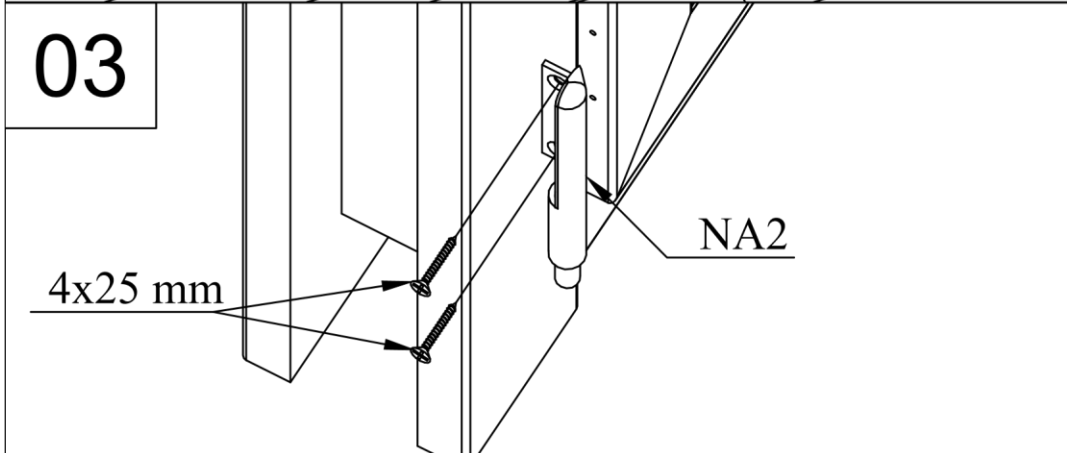

06-1

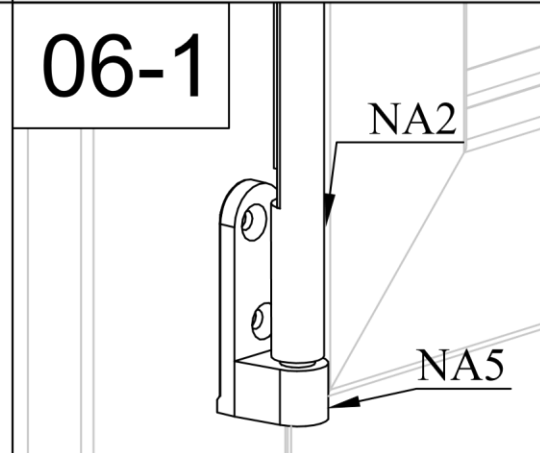

06-2

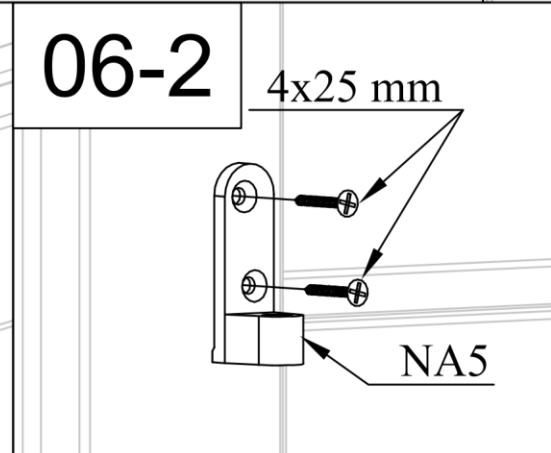

04

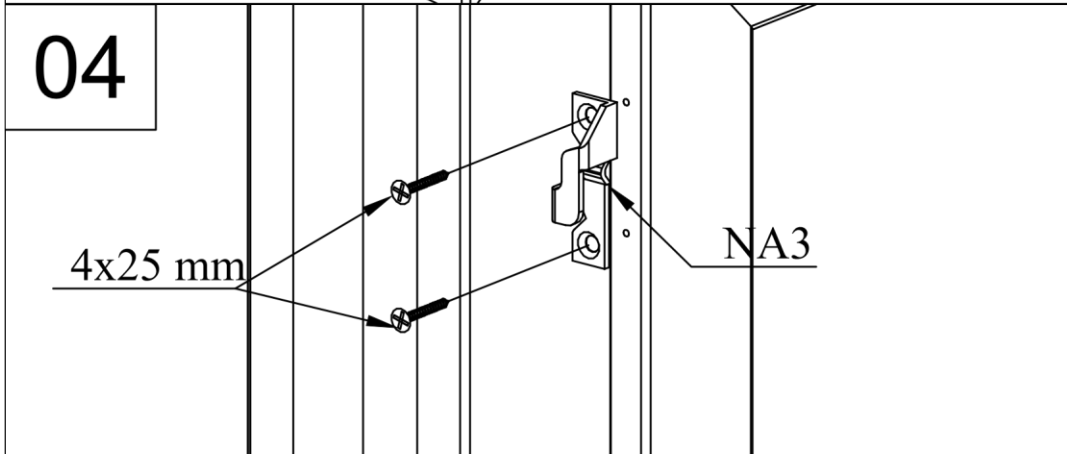

07

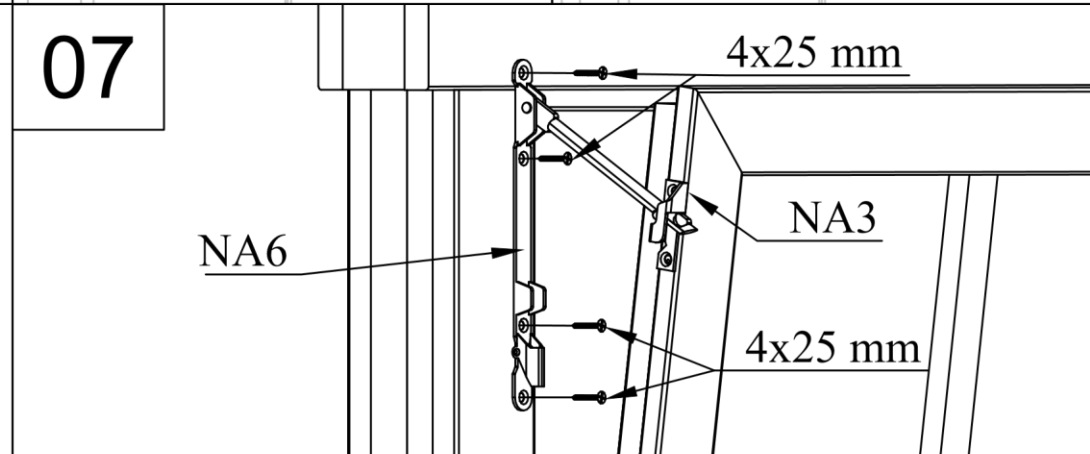

2.5x20 mm

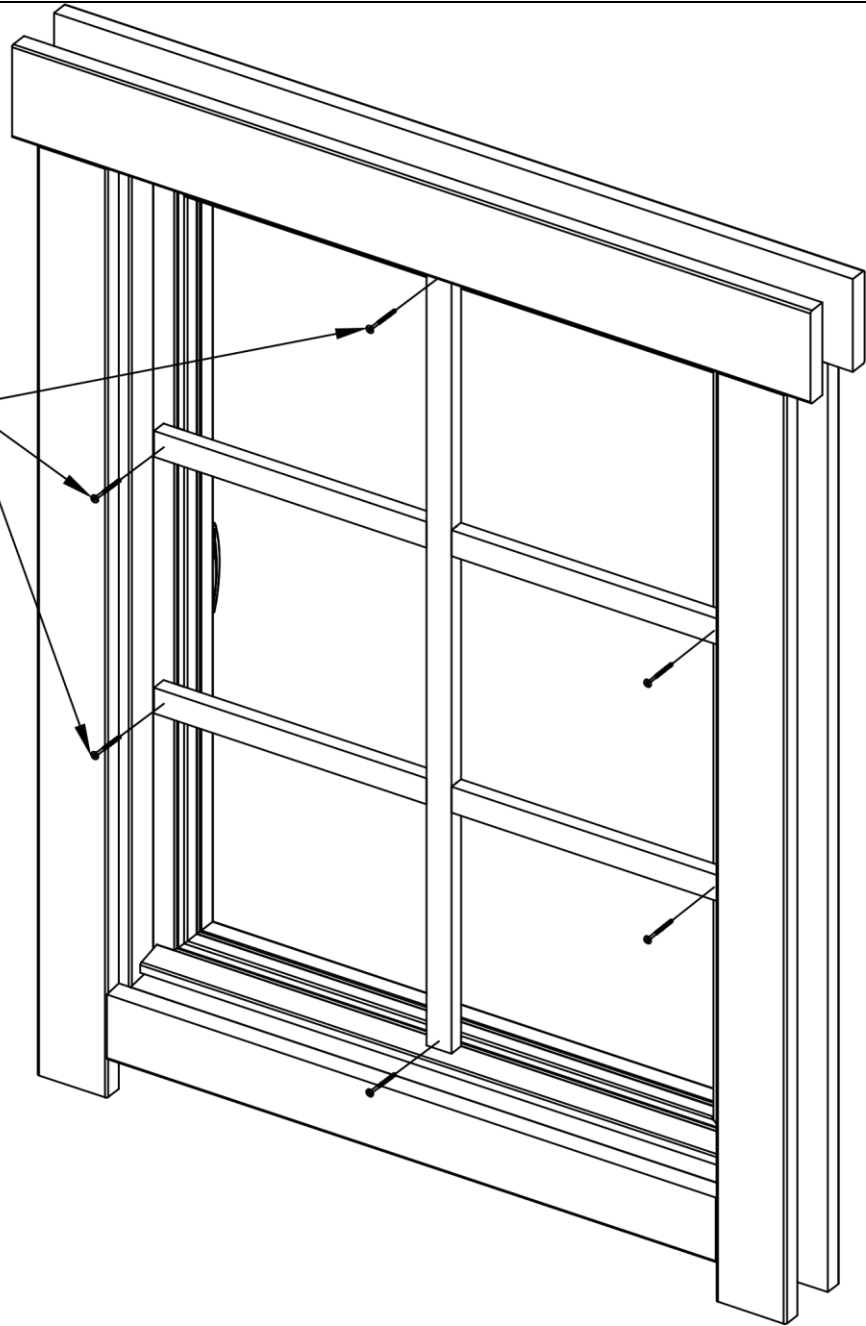

Pos	08.01.2018	Piece list - Stückliste - Liste des pièces - Elementi - Stuklijst - Tükítabel 2390x2020 TUL.2.100.IVP.TA	1/2	Q	P (mm)	L (mm)
-----	------------	---	-----	---	-----------	-----------



2290x1970 mm

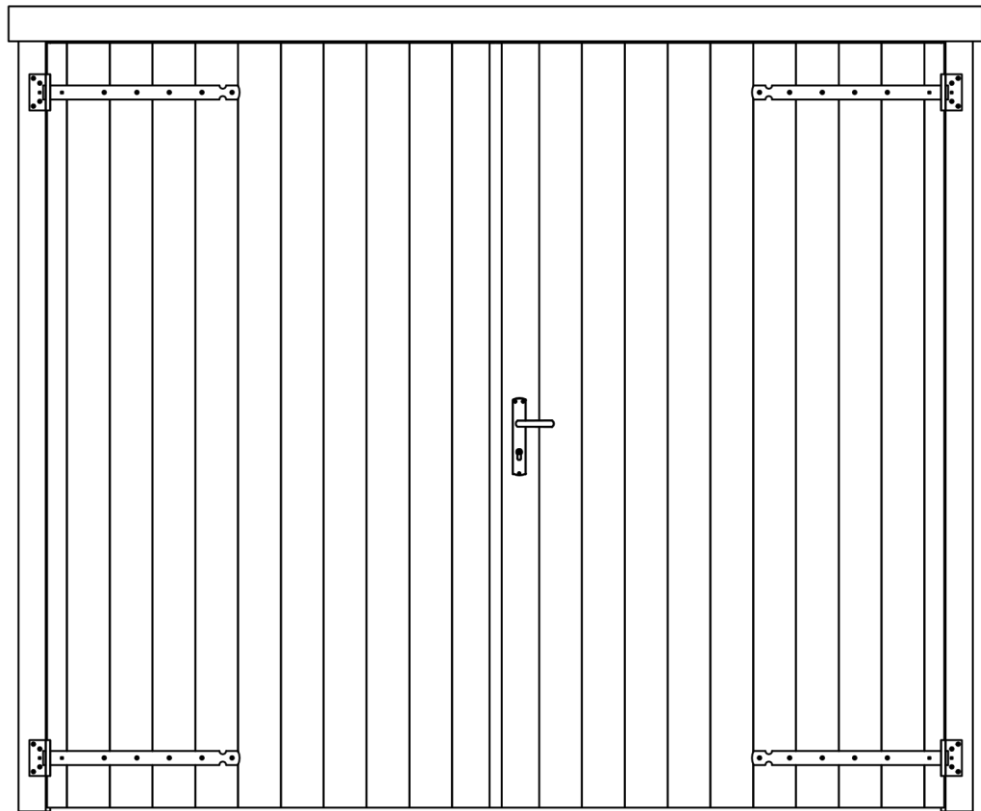

1	Upper door jamb - Türrahmen oben - Cadre de porte supérieur - Telaio superiore della porta - Bovendorpel - Ukse ülemine leng		1		2504
2	Left door jamb - Türrahmen links - Cadre de porte gauche - Telaio montante sinistro della porta - Linkerstijl deurframe - Ukse vasak leng		1		2020
3	Right door jamb - Türrahmen rechts - Cadre de porte droit - Telaio montante destro della porta - Rechterstijl deurframe - Ukse parem leng		1		2020

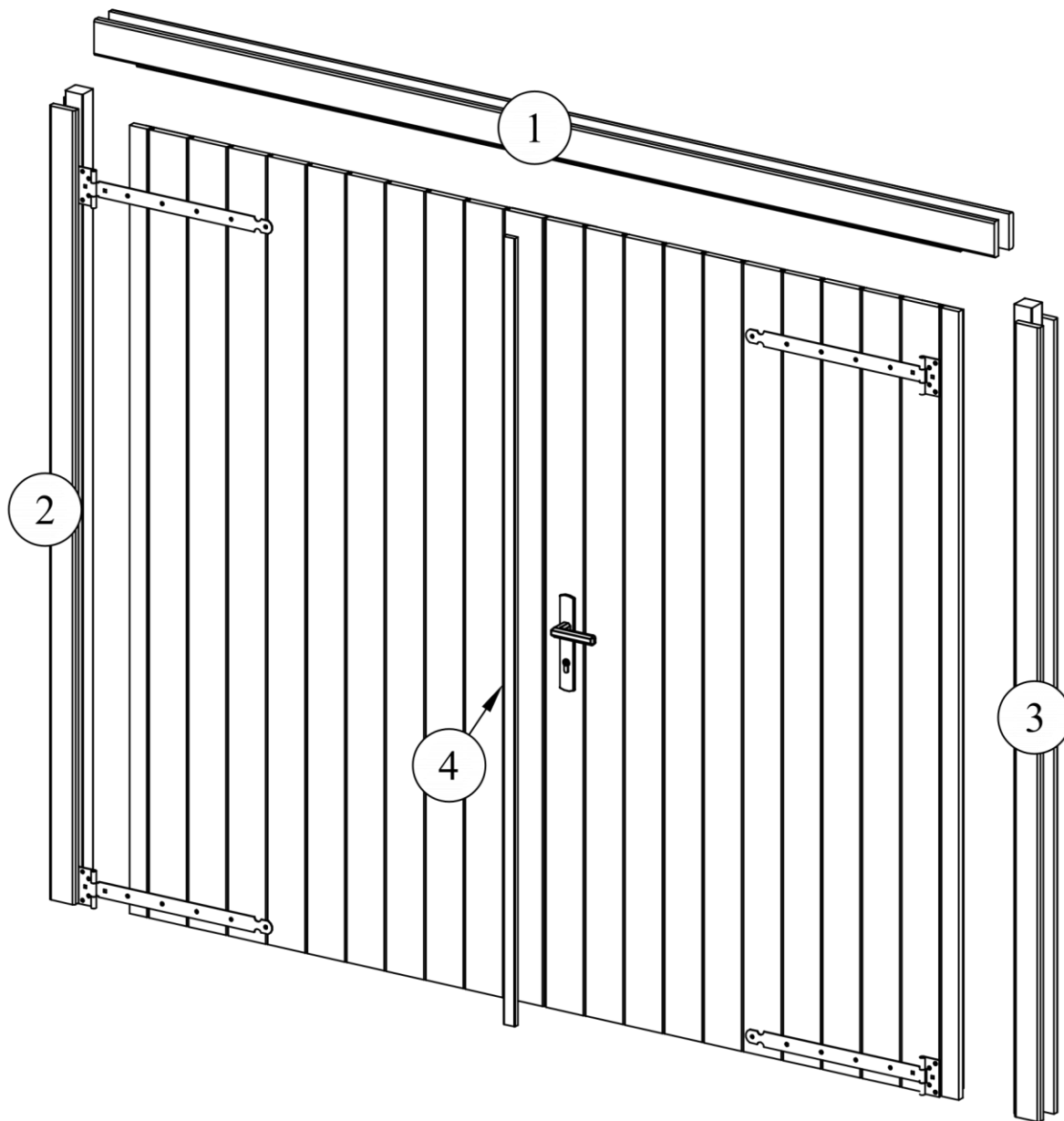

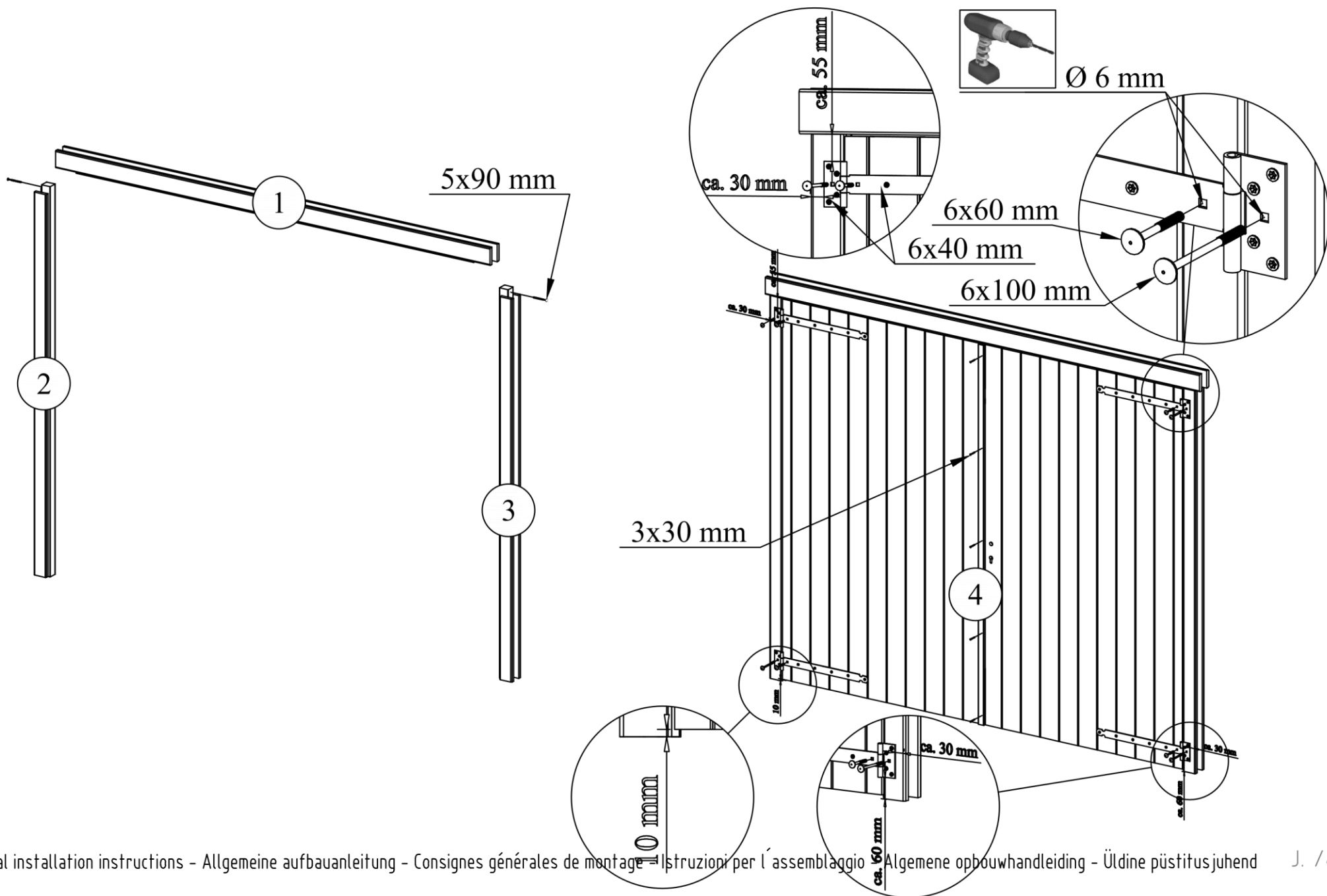

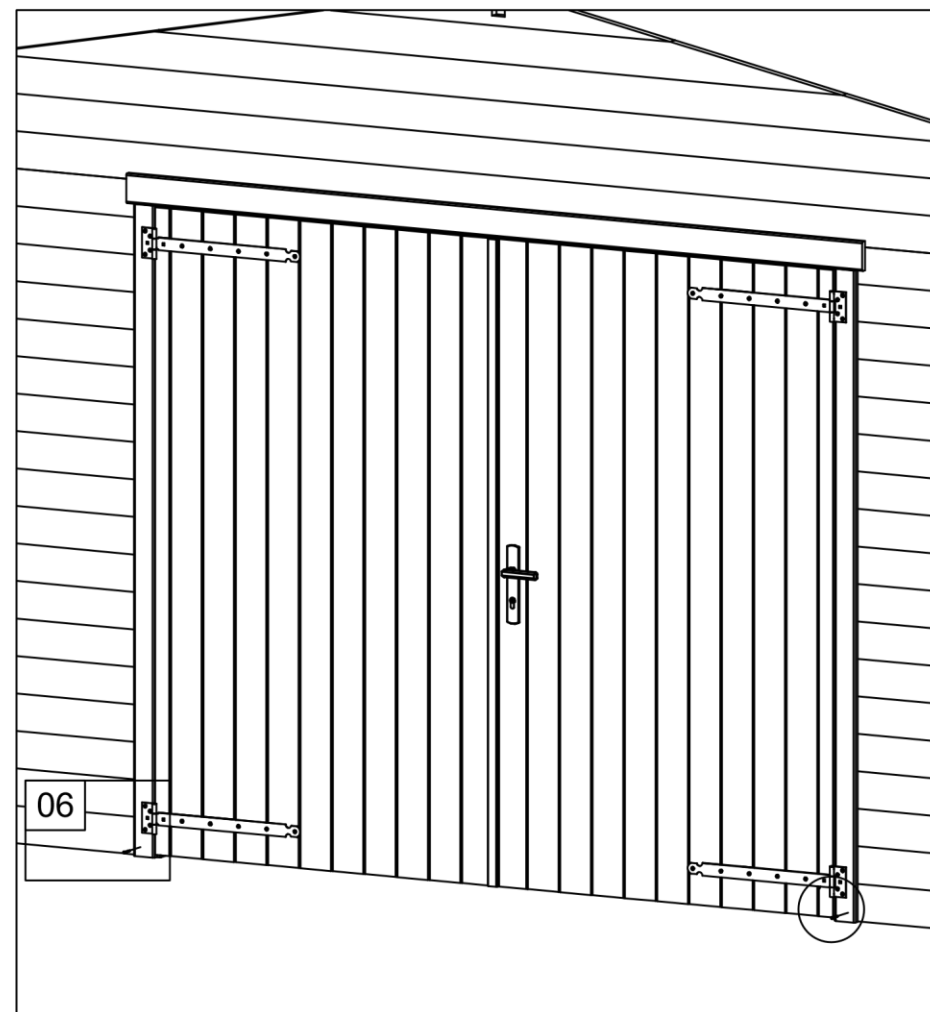
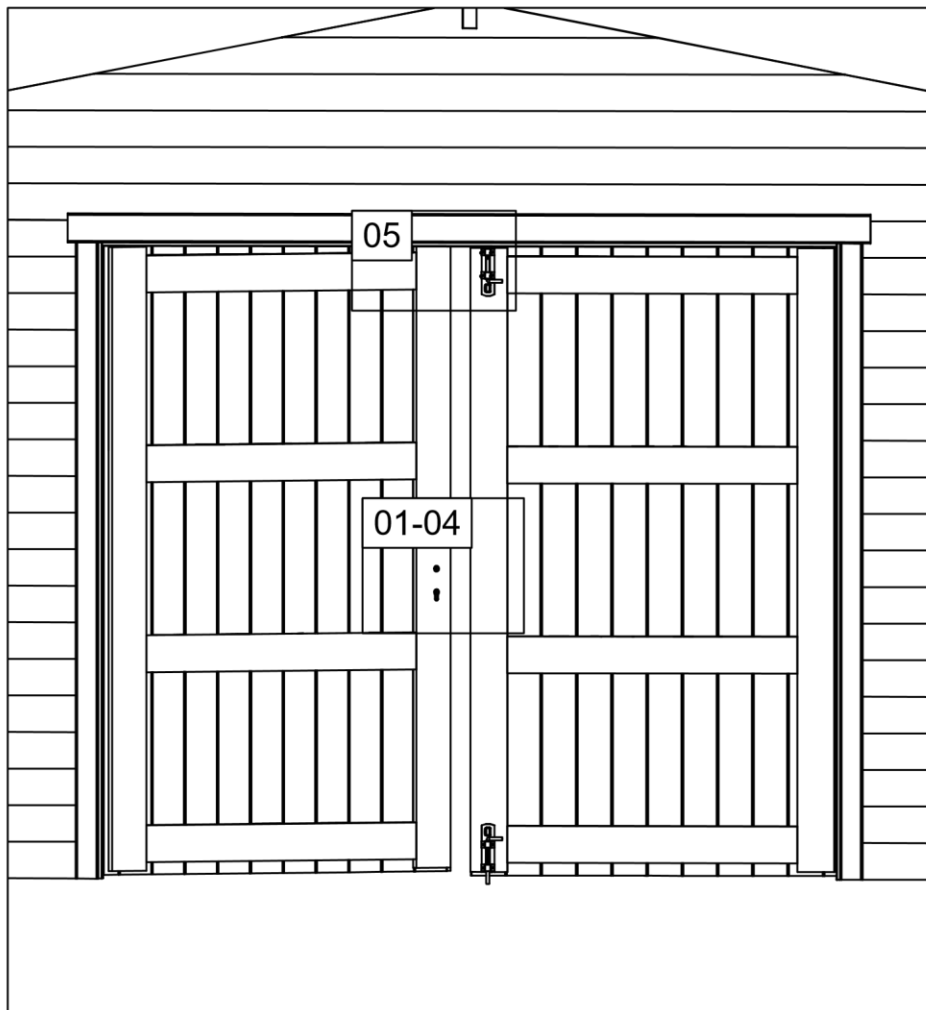

01

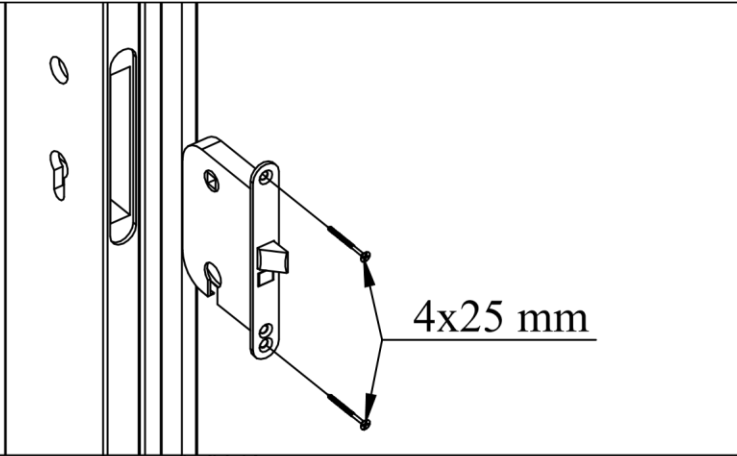

04

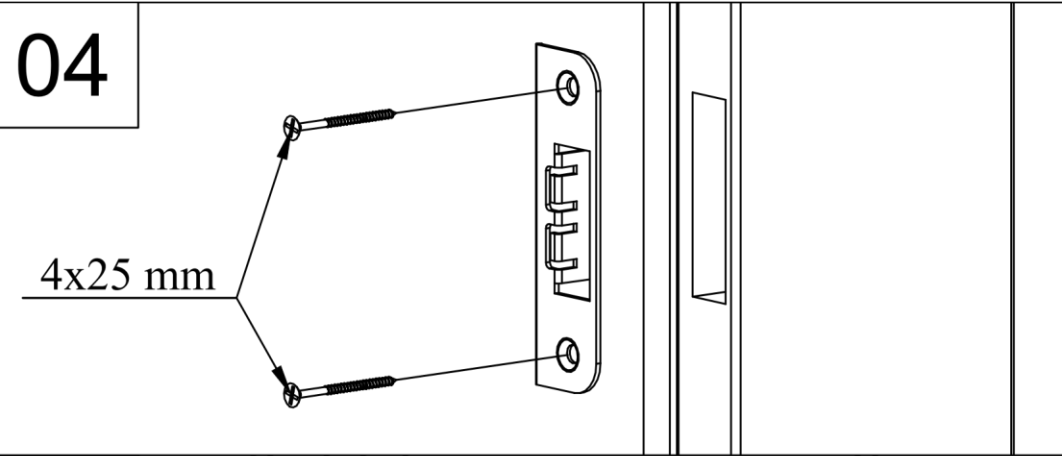

02

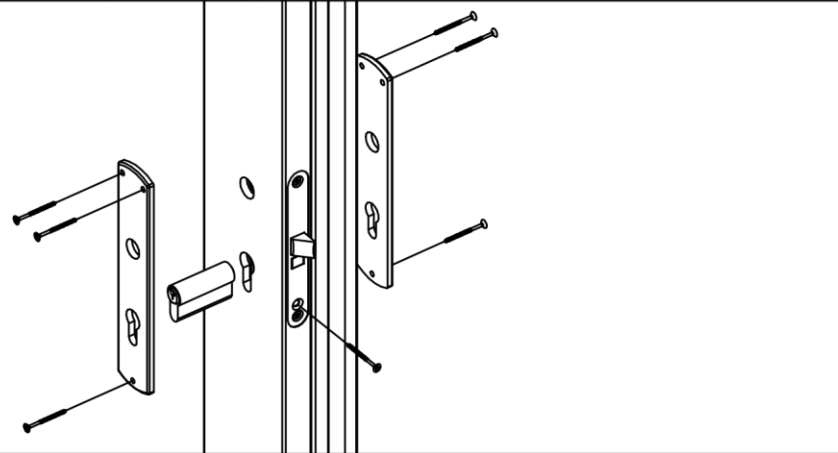

05

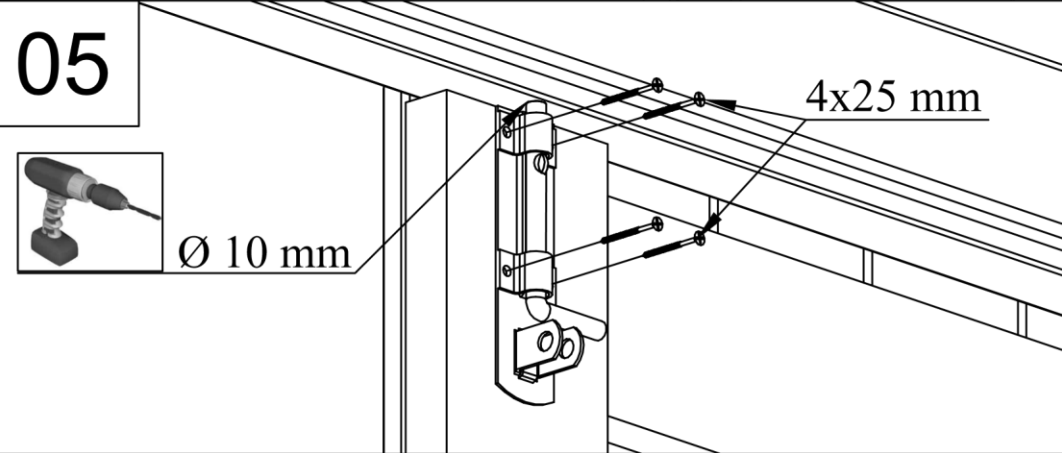

03

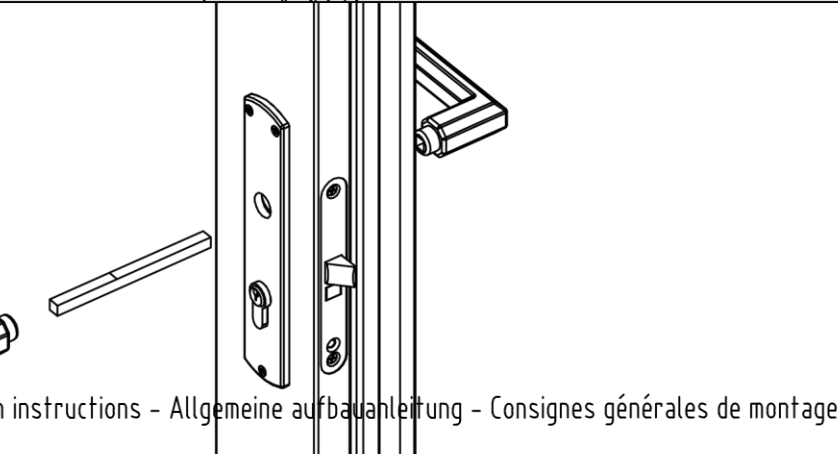

06

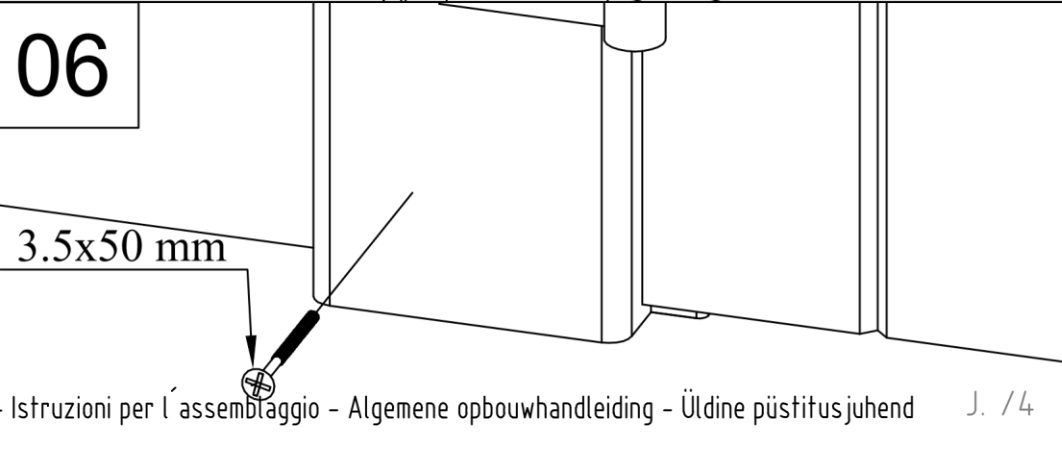



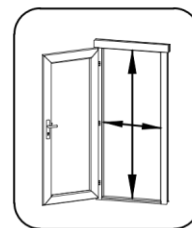
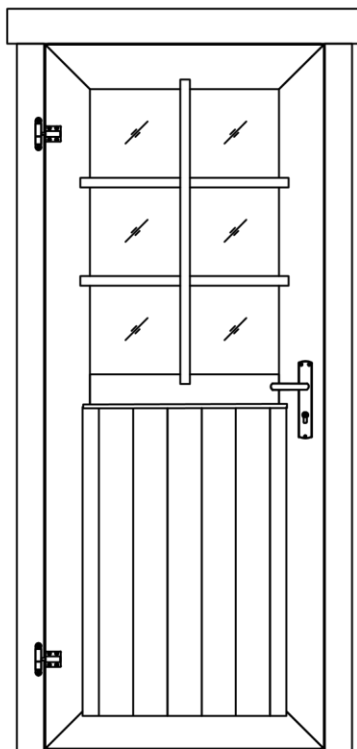

Pos	Piece list - Stückliste - Liste des pièces - Elementi - Stuklijst - Tükitalabel 13.11.2017 775x1850 UK.2.056.SVV.MMX40 SGA+28	1/2	Q	P (mm)	L (mm)
-----	--	-----	---	-----------	-----------

Glass size - Glasgröße - Taille de la vitre - Misura del vetro - Glas afmeting - Klaasi mõõt: 502x750 mm



702x1793 mm

1	Upper door jamb - Türrahmen oben - Cadre de porte supérieur - Telaio superiore della porta - Bovendorpel - Ukse ülemine leng		1	78x100	912
2	Left door jamb - Türrahmen links - Cadre de porte gauche - Telaio montante sinistro della porta - Linkerstijl deurframe - Ukse vasak leng		1	78x80	1850
3	Right door jamb - Türrahmen rechts - Cadre de porte droit - Telaio montante destro della porta - Rechterstijl deurframe - Ukse parem leng		1	78x80	1850
4	Doorstep - Swelle - Barre de seuil - Soglia della porta - Deurdorpel - Lävepak		1	19x30	702
5	Georgian bars - Sprossen - Croisillons - La griglia georgiana - Raamverdeling - Petteliistud		1	15x25	784

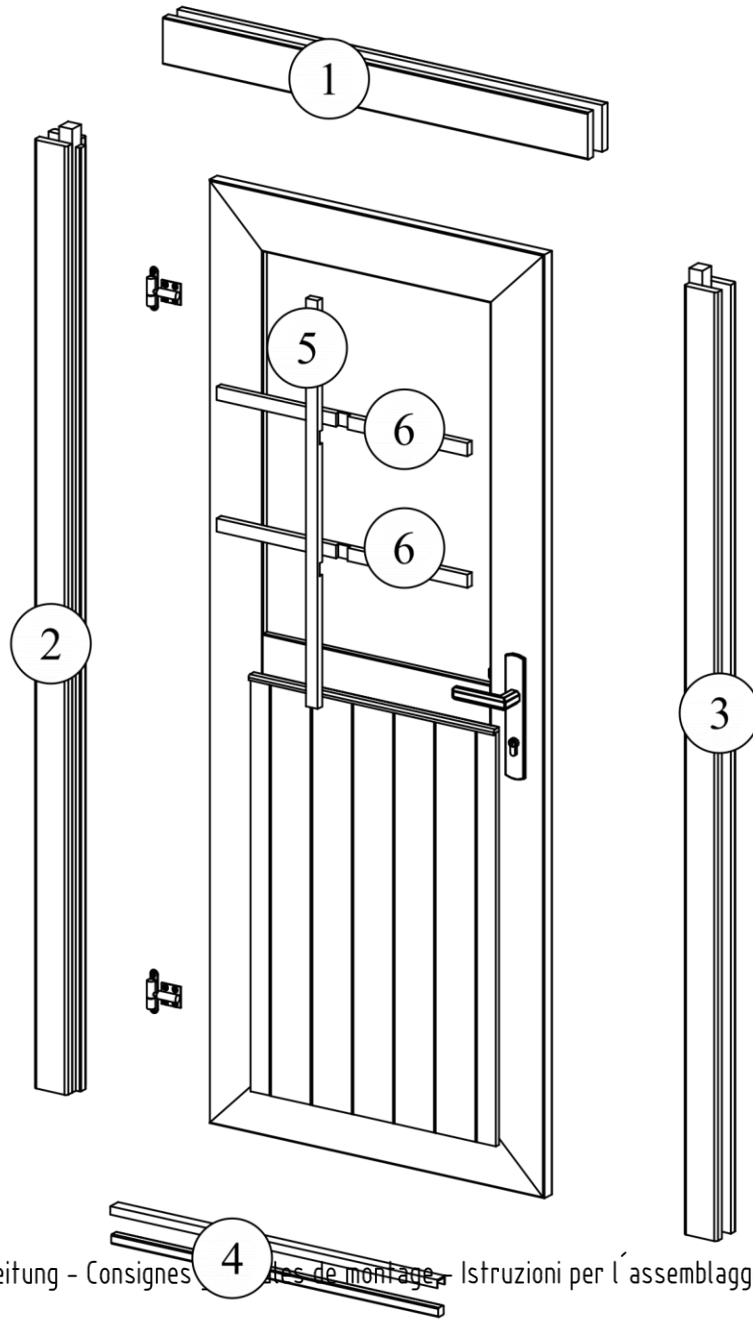

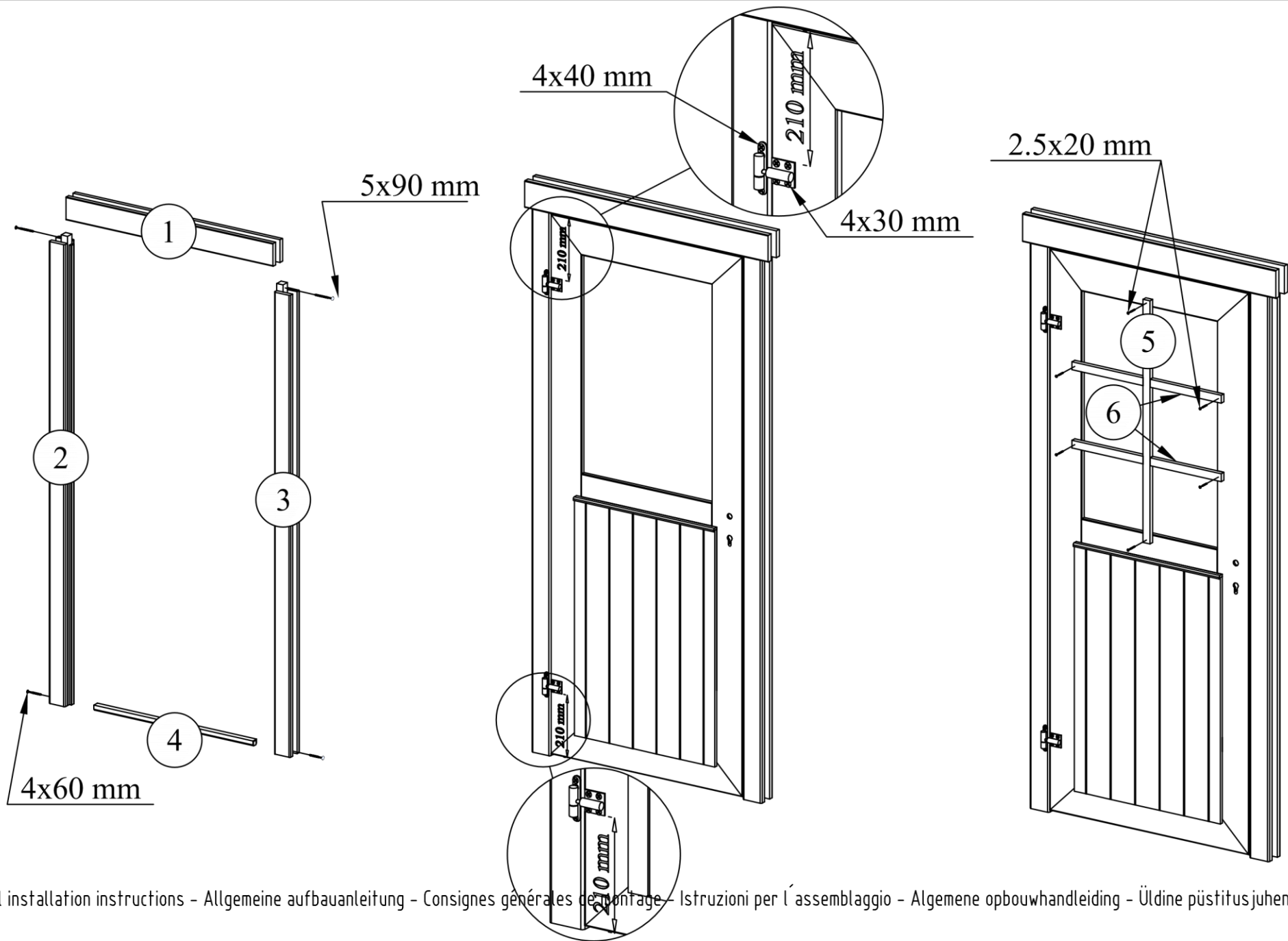

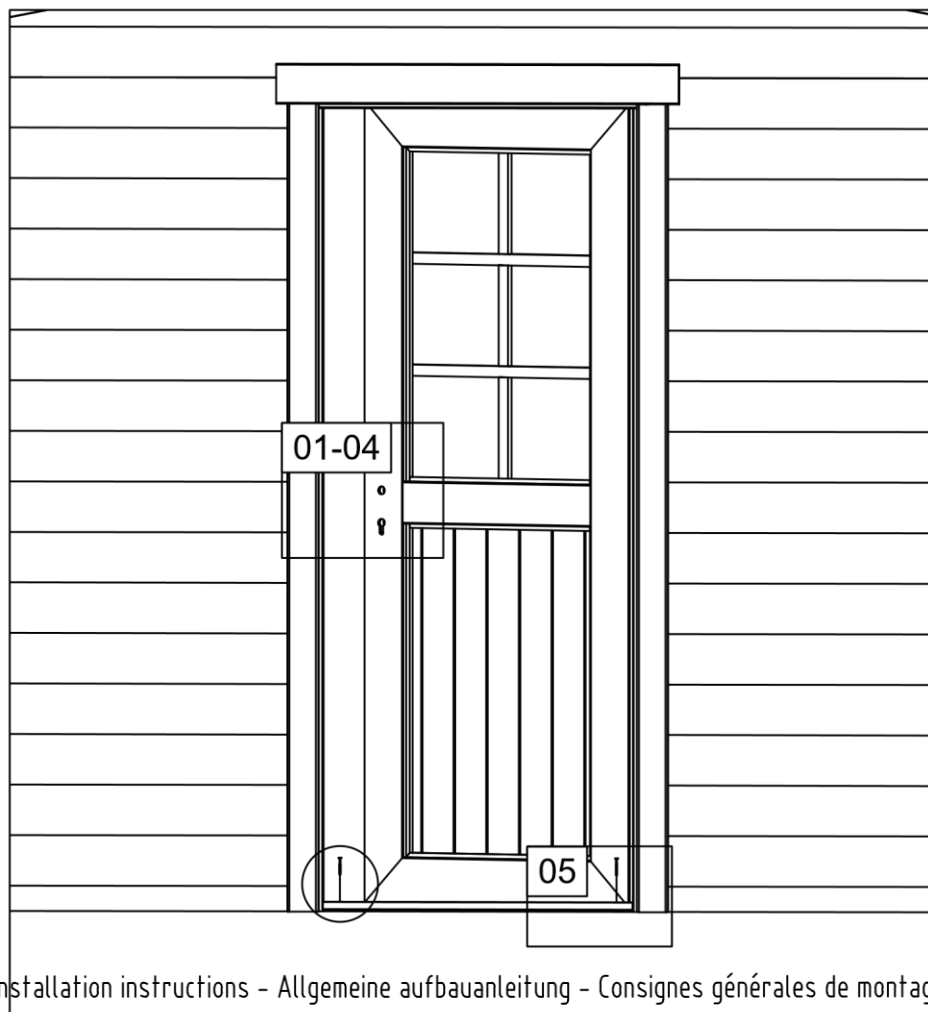

01

4x25 mm

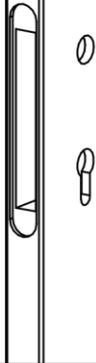
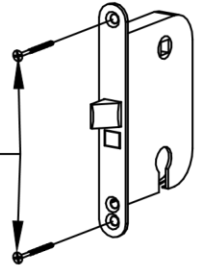

04

4x25 mm

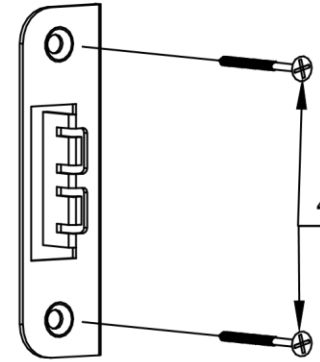

02

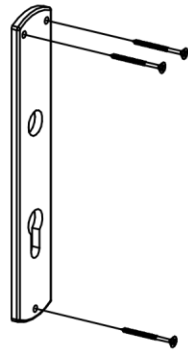
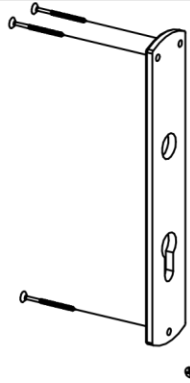

05

4.5x60 mm

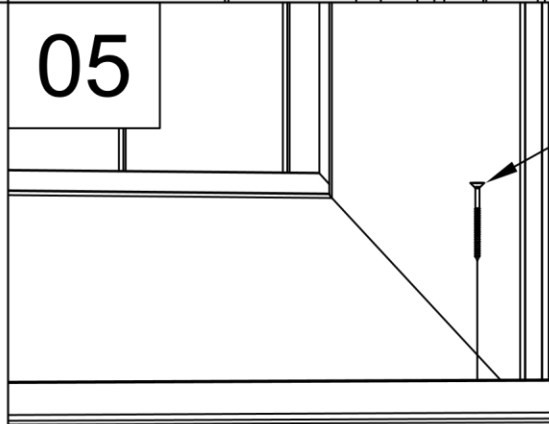

03

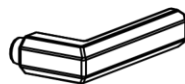
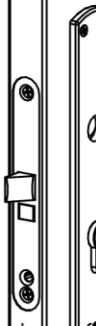
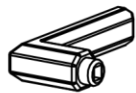

06

3.5x50 mm



General installation instructions - Allgemeine Aufbauanleitung - Consignes générales de montage - Istruzioni per l'assemblaggio - Algemene opbouwhandleiding - Üldine püstitusjuhend