

All dimensions and levels are to be checked on site by the contractor prior to preparation of shop drawings and commencement of works on site.

Do not scale from this drawing.

This drawing and the copyrights and patents therein are the property of ig9 and may not be used or reproduced without prior written consent.

This drawing is to be read in conjunction with all relevant consultant's and/or specialist's drawings/documents and any discrepancies or variations are to be notified to ig9 Limited before the affected work commences.

All windows to have secondary glazing installed internally within the reveals.

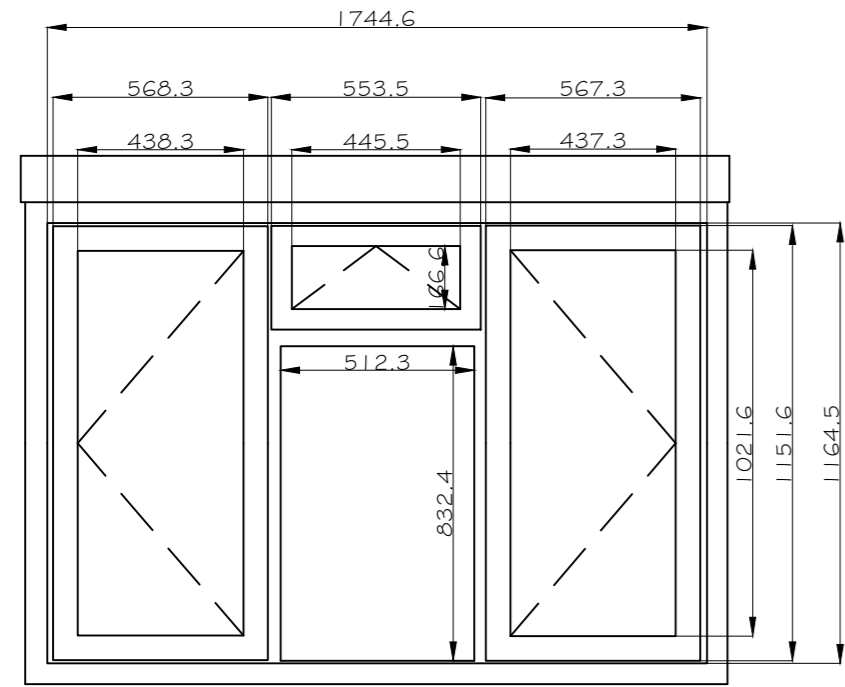

Type A

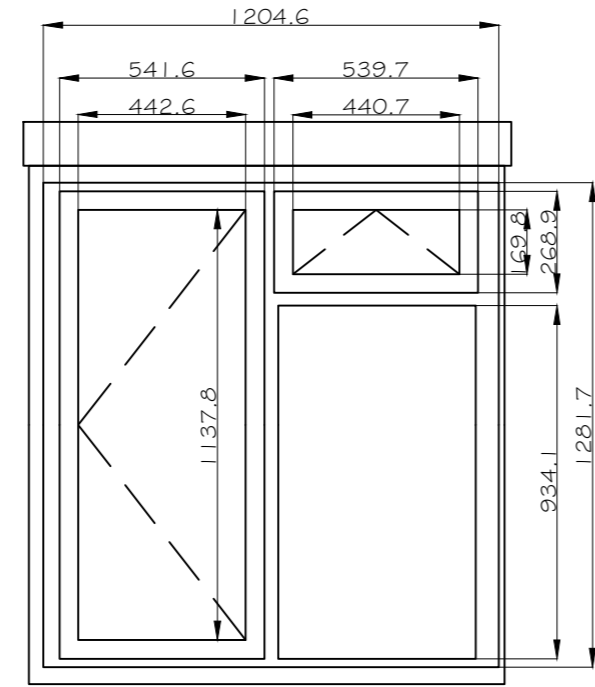

Type B

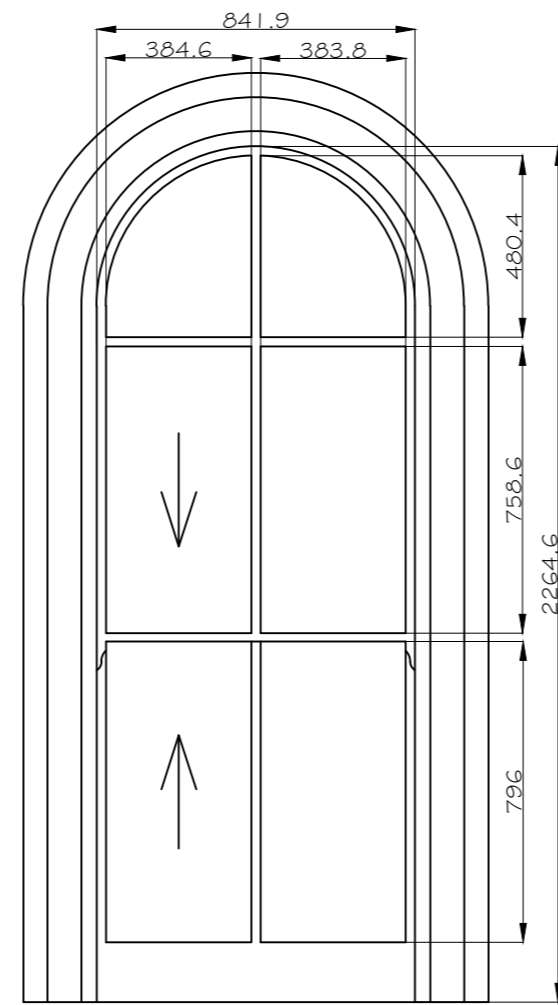

Type C

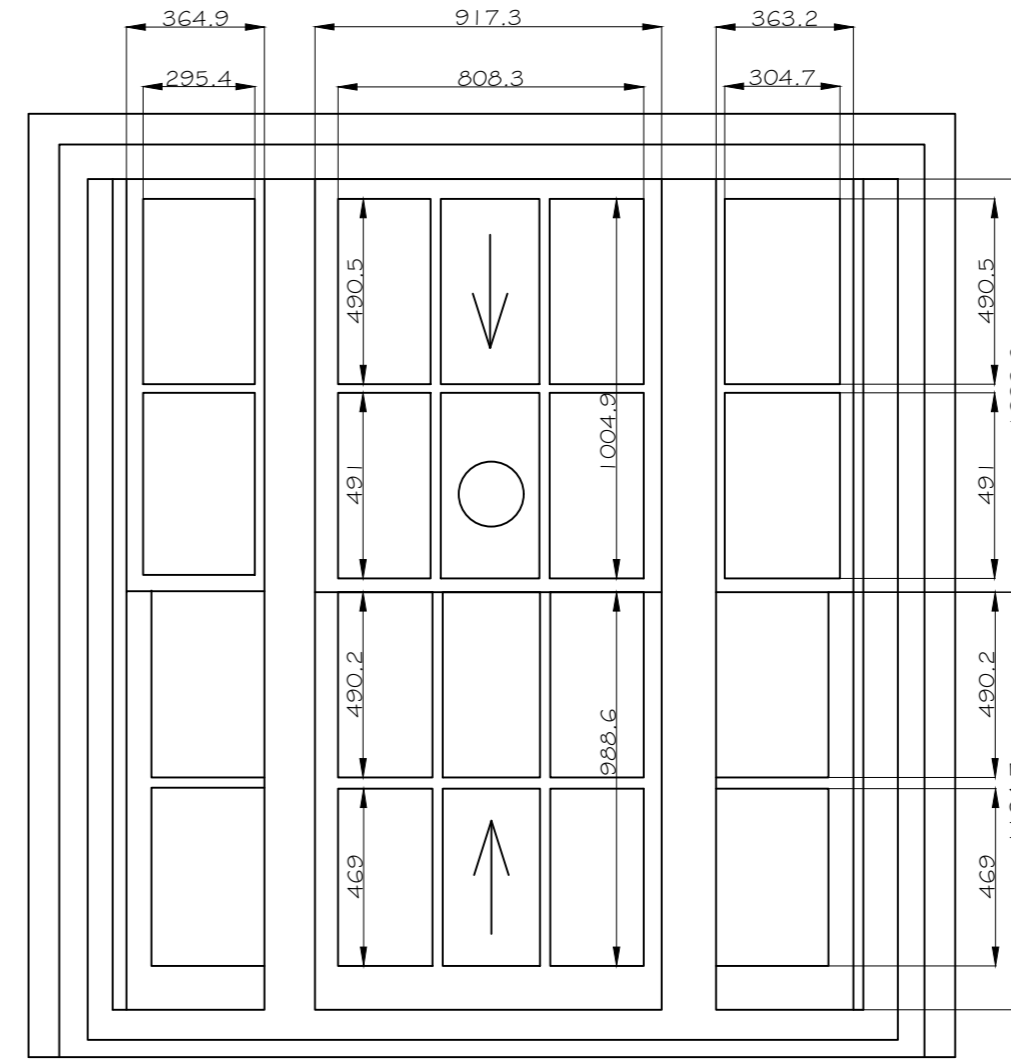

Type D

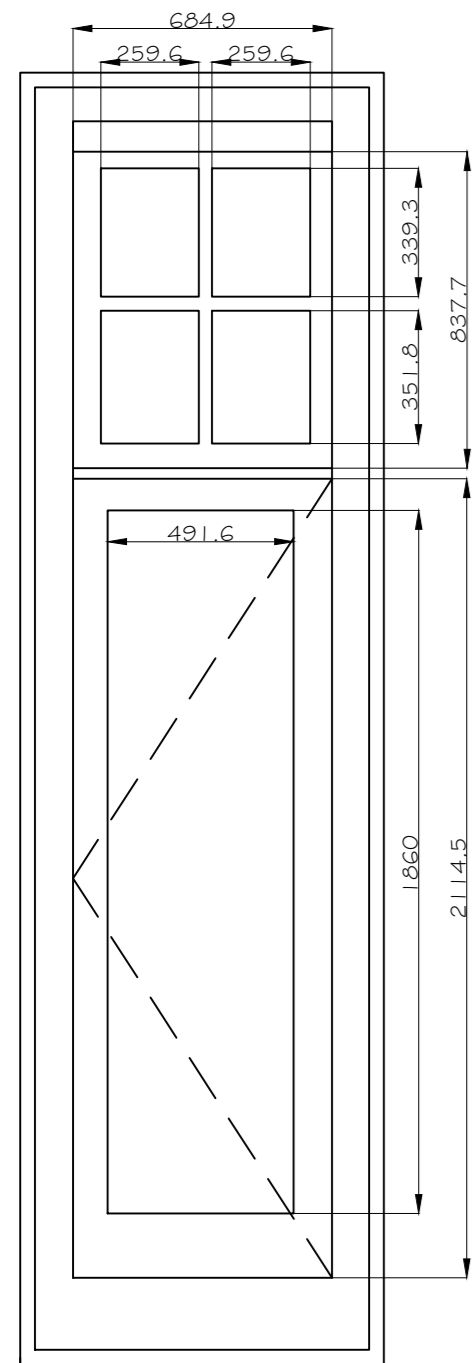

Type E

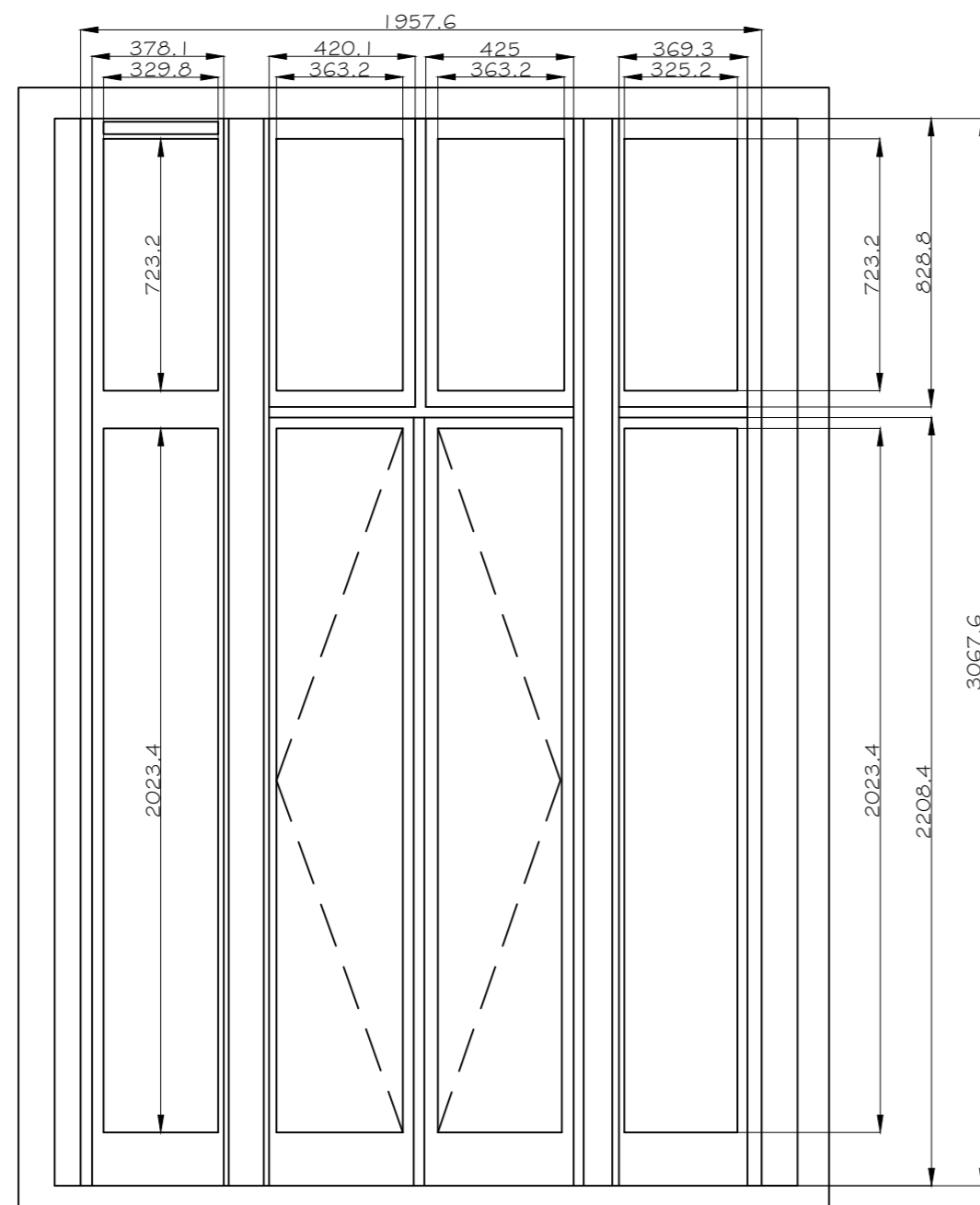

Type F

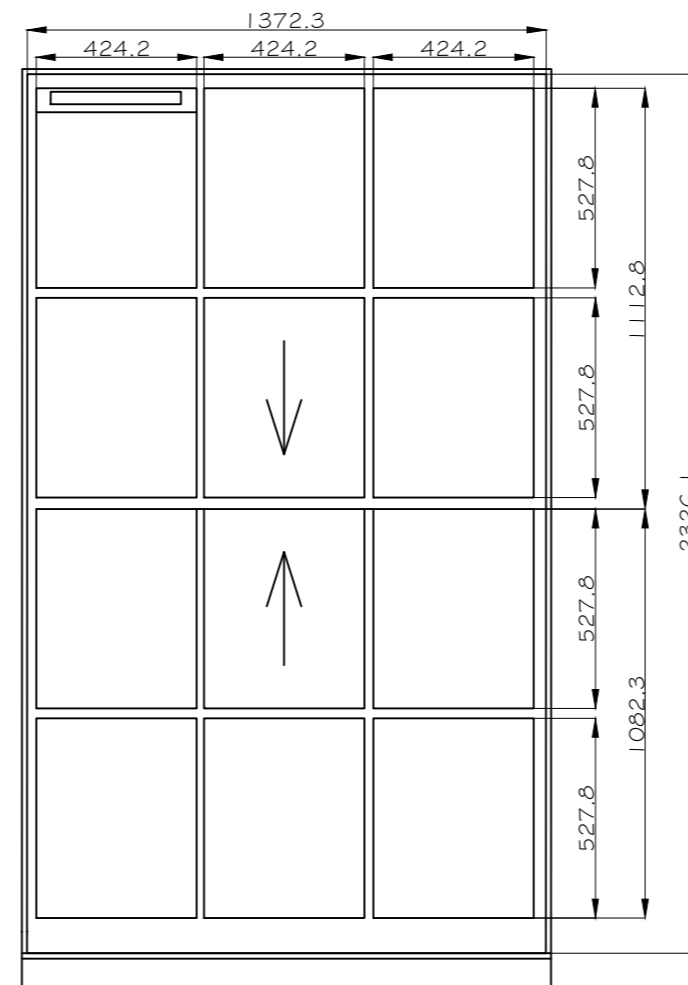

Type G

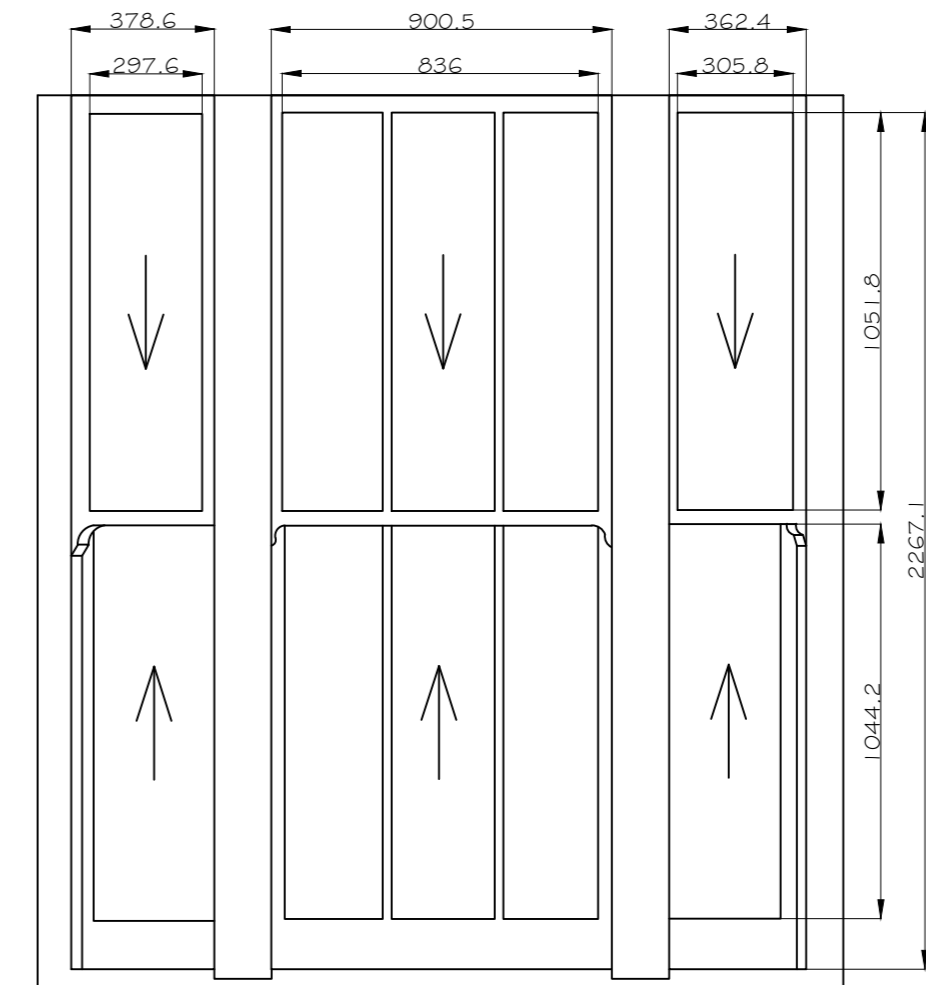

Type H



PI	Sept. 2023	Planning Application
Rev	Date	Description

**ig<sup>9</sup>** 11 Riverside Building  
Trinity Buoy Wharf  
64 Orchard Place  
London  
E14 0FF  
t. 0207 538 4646  
e. info@ig9.co.uk  
w. www.ig9.co.uk

Building Surveying Project Management Cost Consultants  
Consulting Engineers Principal Designer

Client:  
Equans Regeneration Limited

Project:  
167 Gloucester Terrace  
London  
W2 6DX

Title:  
Proposed Windows and Doors  
Proposed Windows Types A-H

Scale:  
1:20@A2

Drawn By:  
LT

Date:  
September 2023

Checked By:  
JB

Drawing No.  
2223-102330-167GT-08

Revision:  
PI