

3D Roof As Existing

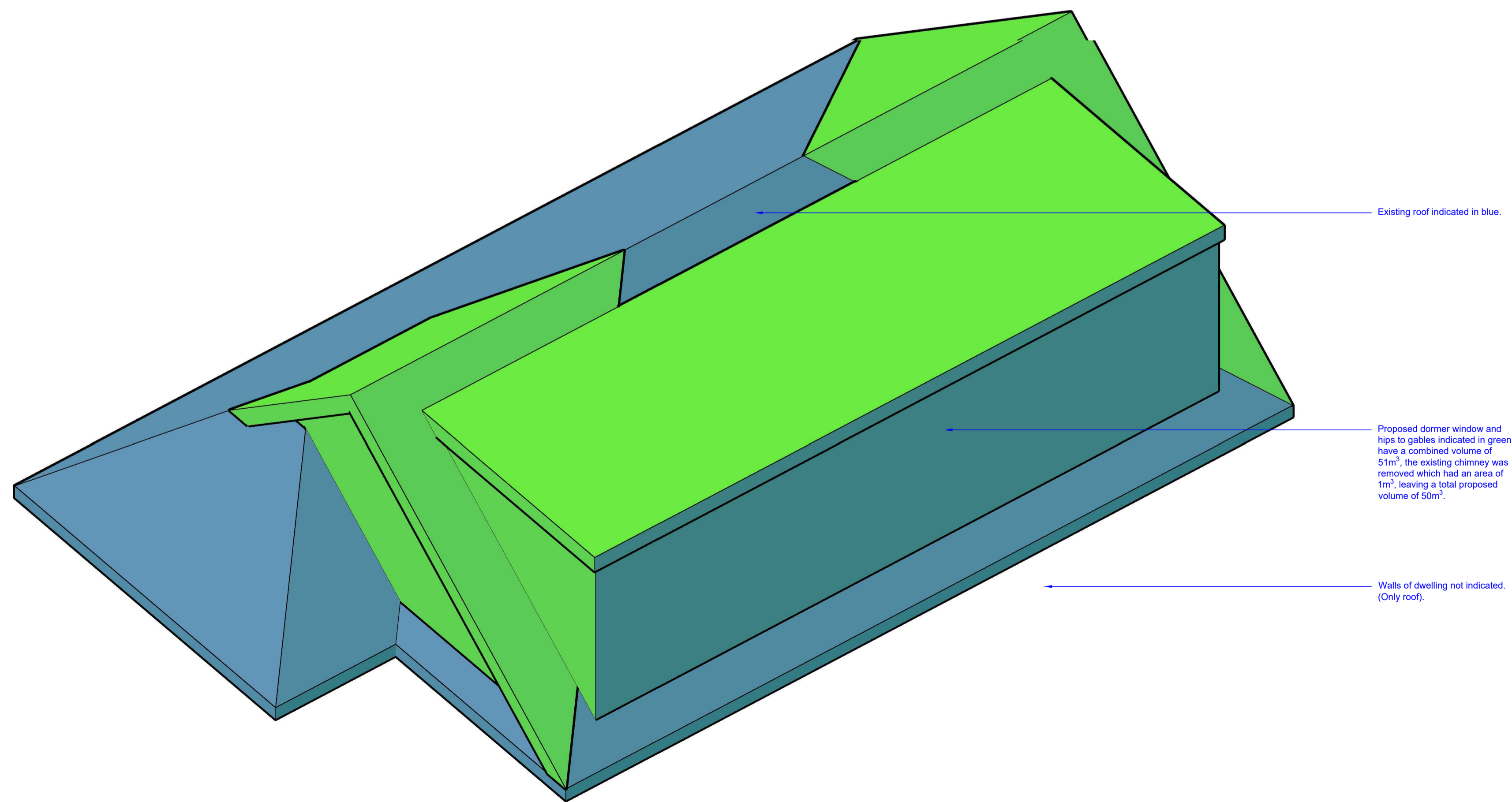

3D Roof As Proposed

Planning Permission

Only figured dimensions on this drawing are to be worked from, all dimensions shown are millimetres unless otherwise stated. It is the responsibility of the client to ensure that all dimensions are correct and that any discrepancies should be reported to the Site Agent or the Client, before proceeding.

Date	No.	Rev.	Model
Client			Job
Mrs L. Stevens			9 Apple Close Exmouth Devon EX8 4QN
Scale	Drawn	Checked	
See Plans @ A1	T.J.D	/	
Date	Drawing		
November 2023	Volumes As Existing And As Proposed		
Drg No.			Drawing
D036-23-R-104			As Existing And As Proposed
			Dillons Design Ltd. 76A Exeter Road Exmouth Devon EX8 1PZ
E-mail -> post@dillonsdesign.co.uk Web -> www.dillonsdesign.co.uk			Tel :- 01395 272739 Fax :- 01395 272739