

Dwelling A Dwelling B

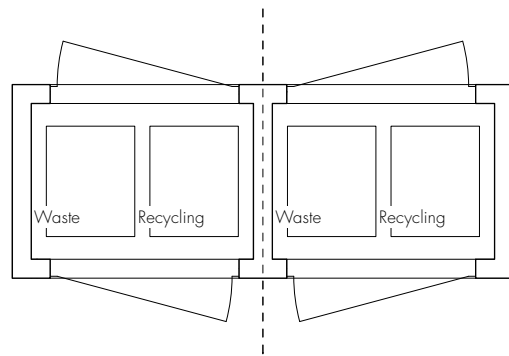

BIN STORE - FLOOR PLAN

Dwelling A Dwelling B

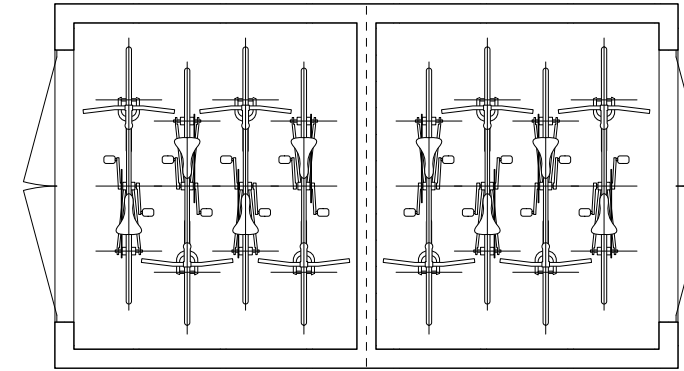

BIKE STORE - FLOOR PLAN

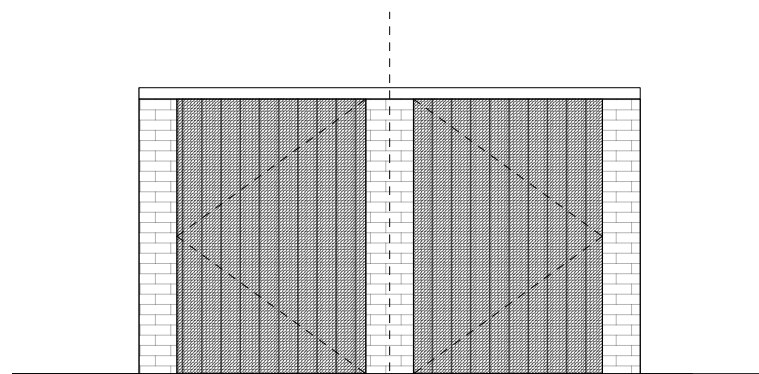

NORTH ELEVATION - BIN STORE

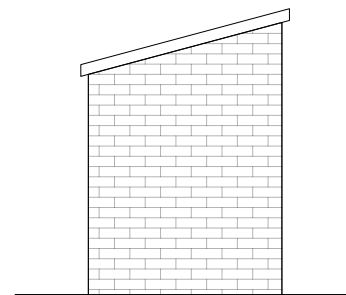

EAST ELEVATION - BIN STORE

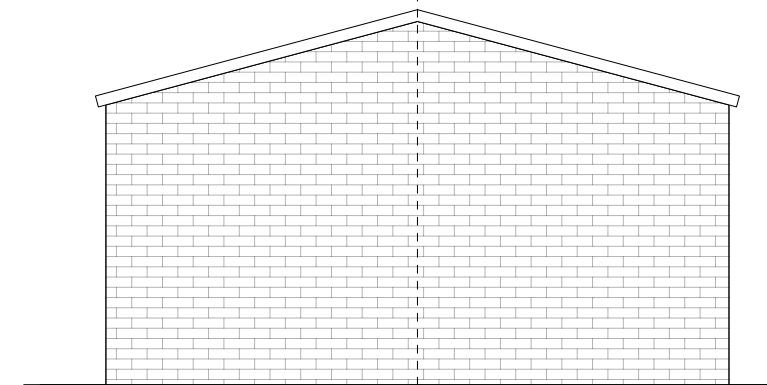

NORTH & SOUTH ELEVATION - BIKE STORE

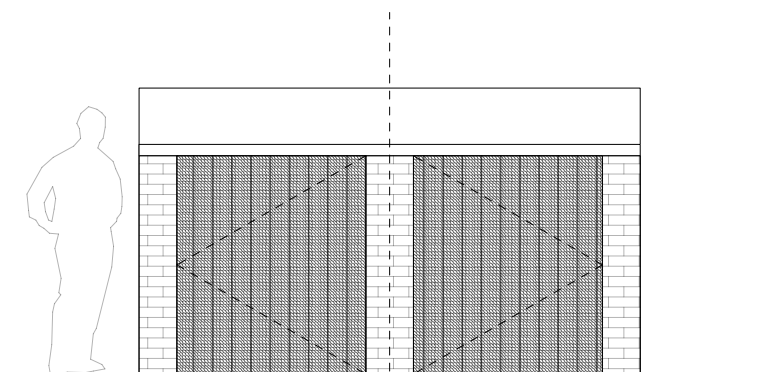

SOUTH ELEVATION - BIN STORE

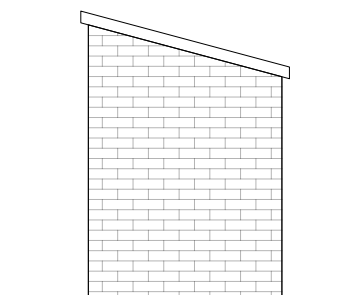

WEST ELEVATION - BIN STORE

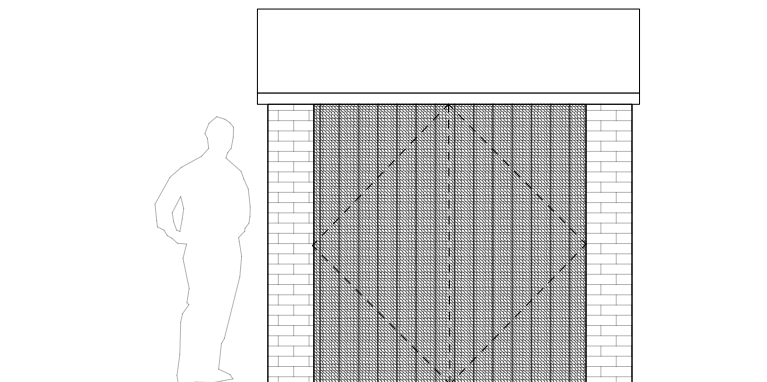

EAST & WEST ELEVATION - BIKE STORE

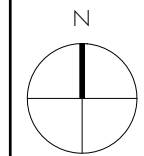

<b>Drawing Status:</b>	<b>RIBA Stage:</b>
<b>Planning</b>	<b>03</b>

<b>Drawing Issue:</b>	
<b>No. Date:</b>	<b>Recipients:</b>

<b>Revisions:</b>	
<b>No. Date:</b>	<b>Revision Notes:</b>

- General Notes:**
1. All dimensions in mm, unless otherwise stated
  2. Do not scale from this drawing unless for planning purposes
  3. All specified items in line with manufacturers recommendation.
  4. All given labels & dimensions to be checked & confirmed on site.
  5. The contractor, sub contractor or specialist contractor should inform the architect of any discrepancies.
  6. Print at 100% scale and not 'scaled to fit page' in print settings.
  7. All rights reserved.

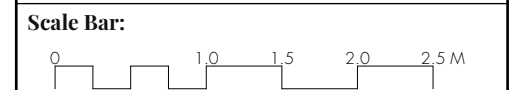

<b>ARNEWOOD COPSE</b> FARMERS WALK EVERTON HAMPSHIRE SO41 0JZ	<b>Project No:</b> 2007
---	----------------------------

<b>PROPOSED BIN &amp; BIKE STORE</b>		
<b>Scale:</b> 1:50	<b>Start Date:</b> [A3] OCTOBER 2021	<b>Drawing No:</b> 23-022