

ITEM 1
FRONT ELEVATION
FIRST FLOOR LEFT
CLEAR 14mm UNITS

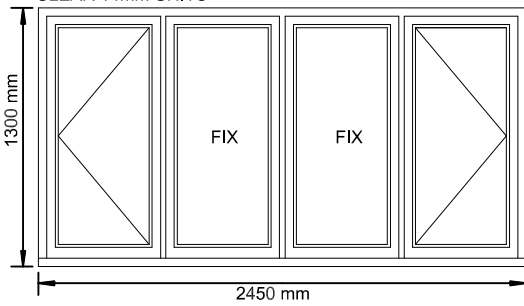

ITEM 2
FRONT ELEVATION
FIRST FLOOR MIDDLE
CLEAR 14mm UNITS

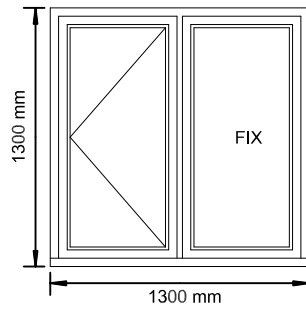

ITEM 4
FRONT ELEVATION
FIRST FLOOR RIGHT
CLEAR 14mm UNITS

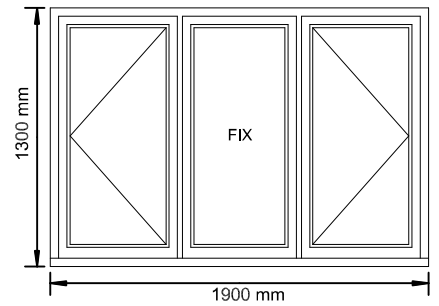

ITEM 5
FRONT ELEVATION
GROUND FLOOR
ANGLED BAY WINDOW
CLEAR 14mm UNITS

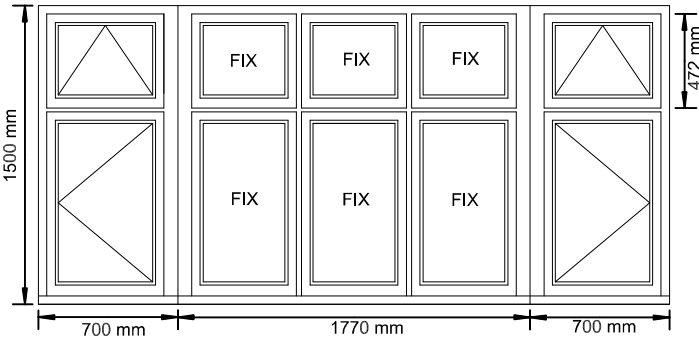

ITEM 7
FRONT ELEVATION
GROUND FLOOR
OBSCURE 14mm UNITS

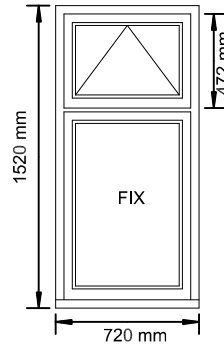

ITEM 9
SIDE ELEVATION
FIRST FLOOR
OBSCURE 14mm UNIT

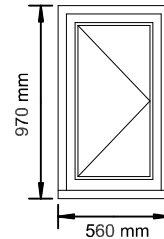

ITEM 10
SIDE ELEVATION
GROUND FLOOR
OBSCURE 14mm UNITS

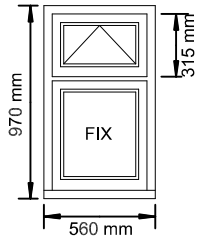

ITEM 11
SIDE ELEVATION
GROUND FLOOR
OBSCURE 14mm UNITS

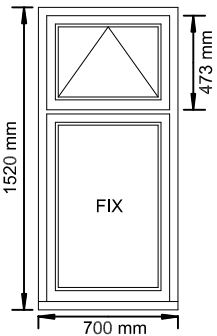

ITEM 12
SIDE ELEVATION
GROUND FLOOR
OBSCURE 14mm UNITS

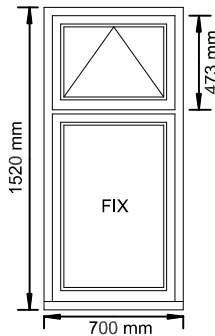

SCALE 1:20 @ A2

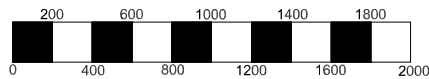

DOKIC JOINERY LTD
CLIENT L BIRD
SITE: 32 CLIDDSDEN ROAD
DRWG: FRONT AND SIDE ELEVATIONS
SCALE: 1-20 @ A2
DATE: 23RD OCTOBER 2023