



CONTENTS

INTRODUCTION

COMPANY PROFILE	- COMPANY & SYSTEMS	Int.1
ACCREDITATION	- REGULATIONS & STANDARDS	Int.2
SIZE LIMITATIONS	- CASEMENT WINDOWS	Int.3
	- TILT & TURN WINDOWS, REVERSIBLE WINDOWS	Int.4
	- DOORS	Int.5
	- VERTICAL SLIDER, RIDE OVER PATIO	Int.6
REINFORCEMENT	- REQUIREMENTS	Int.7

ELITE 70

PRODUCT GUIDE	- MAIN PROFILES	E70.1
	- GLAZING BEADS, ANCILLARIES	E70.2
	- BAY COUPLINGS, COUPLING MULLIONS	E70.3
GENERAL ASSEMBLIES	- INTERNALLY BEADED CASEMENT (BEVELLED)	E70.4
	- INTERNALLY BEADED CASEMENT (OVOLO)	E70.5
	- EXTERNALLY BEADED CASEMENT (BEVELLED)	E70.6
	- EXTERNALLY BEADED CASEMENT (OVOLO)	E70.7
	- TILT & TURN WINDOW (BEVELLED)	E70.8
	- TILT & TURN WINDOW (OVOLO)	E70.9
	- SINGLE DOOR - OPEN-IN LOW THRESHOLD (BEVELLED)	E70.10
	- SINGLE DOOR - OPEN-IN LOW THRESHOLD (OVOLO)	E70.11
	- SINGLE DOOR - OPEN-OUT (BEVELLED)	E70.12
	- SINGLE DOOR - OPEN-OUT (OVOLO)	E70.13
	- FRENCH DOORS (BEVELLED)	E70.14
	- FRENCH DOORS (OVOLO)	E70.15
	- BI-FOLDING DOORS (BEVELLED)	E70.16
	- BI-FOLDING DOORS (OVOLO)	E70.17

Reversible 70

PRODUCT GUIDE	- OUTER FRAMES, TRANSOMS/MULLIONS, SASHES, BEADS	R70.1
	- BAY COUPLINGS, COUPLING MULLIONS, ANCILLARIES	R70.2
GENERAL ASSEMBLIES	- REVERSIBLE WINDOW	R70.3

This publication contains information of a technical nature and consequently is only intended for use by persons who are skilled in the subject matter covered.

Although reasonable care has been taken in the preparation of this publication, Spectus Window Systems do not accept any liability for damage resulting (whether directly or indirectly) from the use of the information contained in this publication.

It is the responsibility of the specifier to check with all updates on standards and regulations contained in this publication.

Accordingly this publication is supplied on the basis that the specifier accepts all risks associated with the use of the information contained within it.

Spectus maintain a policy of continuous product development and reserves the right to change the specifications of its products without prior notice.



CONTENTS

ELITE 63

PRODUCT GUIDE	- MAIN PROFILES	E63.1
	- ANCILLARIES, BAY COUPLINGS, COUPLING MULLIONS	E63.2
	- ANCILLARIES, BAY COUPLINGS, COUPLING MULLIONS	E63.3
GENERAL ASSEMBLIES	- INTERNALLY BEADED CASEMENT (CHAMFERED)	E63.4
	- INTERNALLY BEADED CASEMENT (OVOLO)	E63.5
	- EXTERNALLY BEADED CASEMENT (CHAMFERED)	E63.6
	- EXTERNALLY BEADED CASEMENT (OVOLO)	E63.7
	- EXTERNALLY BEADED CASEMENT (SLIM SASH)	E63.8
	- TILT & TURN WINDOW	E63.9
	- SINGLE DOOR (OPEN-IN LOW THRESHOLD)	E63.10
	- SINGLE DOOR (OPEN-OUT)	E63.11
	- FRENCH DOORS	E63.12
	- BI-FOLDING DOORS	E63.13

CILLS

PRODUCT GUIDE	- CILLS	CL.1
----------------------	---------	------

VERTICAL SLIDER

PROFILE GUIDE	- MAIN PROFILES	VS.1
GENERAL ASSEMBLIES	- STANDARD CONFIGURATION (VERTICAL SECTION)	VS.2
	- STANDARD CONFIGURATION (HORIZONTAL SECTION)	VS.3
	- HEAVY DUTY CONFIGURATION (VERTICAL SECTION)	VS.4
	- HEAVY DUTY CONFIGURATION (HORIZONTAL SECTION)	VS.5

RIDE OVER PATIO

PRODUCT GUIDE	- MAIN PROFILES	ROP.1
GENERAL ASSEMBLIES	- EXTERNAL SLIDING SASH	ROP.2
	- INTERNAL FIXED SASH	ROP.3
	- 2 PANE CONFIGURATION	ROP.4
	- 3 PANE CONFIGURATION	ROP.5
	- 4 PANE CONFIGURATION	ROP.6



PRODUCT GUIDE	- MAIN PROFILES	F.1
	- APPLICATION GUIDE	F.2
GENERAL ASSEMBLIES	- FLUSH REVEAL	F.3
	- OUTSIDE WINDOW FIT	F.4
	- INSIDE WINDOW FIT	F.5
	- CHECK REVEAL	F.6



CONTENTS

CURTAIN WALLING

PRODUCT GUIDE - MAIN COMPONENTS CW.1

GENERAL ASSEMBLIES - HEAD FIXING, CILL FIXING - 70mm PROFILES CW.2
 - JAMB FIXING, INTERMEDIATE MULLION - 70mm PROFILES CW.3
 - TIE-BACK DETAIL, CORNER DETAILS - 70mm PROFILES CW.4
 - HEAD FIXING , CILL FIXING - 63mm PROFILES CW.5
 - JAMB FIXING, INTERMEDIATE MULLION - 63mm PROFILES CW.6
 - TIE-BACK DETAIL, CORNER DETAILS - 63mm PROFILES CW.7

GENERAL

PERFORMANCE - DESIGN DATA Gen.1
 - WINDLOADING - CALCULATION METHOD Gen.2
 - WINDLOADING - REQUIRED RIGIDITY Gen.3
 - WINDLOADING - SECTION PROPERTIES Gen.4
 - WINDLOADING - ELITE 70 PROFILES Gen.5
 - WINDLOADING - REVERSIBLE 70 PROFILES Gen.6
 - WINDLOADING - ELITE 63 PROFILES Gen.7
 - WINDLOADING - COUPLING PROFILES Gen.8
 - LOAD-BEARING BAYPOLES Gen.9
 - THERMAL - WHOLE WINDOW U VALUES & CO² EMISSIONS Gen.10
 - THERMAL - WINDOW ENERGY RATING (WER) Gen.11
 - THERMAL - DOCUMENT L & RESULTS Gen.12
 - VENTILATION - DOCUMENT F - EXTRACT & PURGE VENTILATION Gen.13
 - VENTILATION - DOCUMENT F - WHOLE BUILDING VENTILATION Gen.14
 - VENTILATION - DOCUMENT F - REPLACEMENT WINDOWS Gen.15
 - SOUND INSULATION Gen.16
 - SOUND INSULATION Gen.17

INSTALLATION - PREPARATION Gen.18
 - PREPARATION Gen.19
 - INSTALLATION Gen.20
 - INSTALLATION Gen.21

- FIRE PERFORMANCE OF PVC-U WINDOW FRAMES Gen.22
 - FIRE EGRESS FOR WINDOWS Gen.23

SAFETY - ACCESS TO BUILDINGS Gen.24
 - SAFETY GLASS Gen.25
 - SAFE OPENING & CLOSING FOR WINDOWS Gen.26
 - SAFE ACCESS FOR CLEANING Gen.27
 - PROTECTION FROM COLLISION WITH OPEN WINDOWS Gen.28
 - PROTECTION FROM COLLISION WITH OPEN WINDOWS Gen.29
 - DECORATIVE ANCILLARIES, PROFILE FINISHES, GUARANTEE Gen.30

OPTIONS / GUARANTEE - CLEANING PVC-U PROFILES Gen.31

OPERATION & MAINTENANCE - CASEMENT WINDOWS Gen.32
 - RESIDENTIAL DOORS Gen.33
 - TILT & TURN WINDOWS Gen.34
 - REVERSIBLE WINDOWS Gen.35
 - VERTICAL SLIDING WINDOWS Gen.36

ENVIRONMENT - ENVIRONMENTAL POLICY, ISO 14000, VINYL 2010 & RECOVINYL Gen.37
 - PVC MANUFACTURE AND DISPOSAL Gen.38
 - RECYCLING AND SUSTAINABILITY Gen.38



INTRODUCTION - COMPANY PROFILE

COMPANY & SYSTEMS

Spectus Window Systems

Spectus Window Systems is the market leader in the production of PVC-U windows and door systems.

Across the UK, Spectus Window Systems provides innovative, class leading solutions to the construction industry and this specifiers guide details those products.

Spectus Window Systems offers the professional specifier unique supply opportunities backed by specialist product knowledge, independent quality assessments, and industry leading R & D capabilities.

Spectus Window Systems offers specifiers of PVC-U windows and doors an exceptional range of products and services.

Partnership

At Spectus, our business - and reputation - is built on trust, integrity and service.

We take the time to understand and appreciate the needs of specifiers and builders. We believe this approach allows us to provide a comprehensive service at both national and regional levels, enabling us to deliver "Best Value" to all segments of your build programme.

Innovation

At Spectus, innovation is a way of life, one which leads us to develop window and door products that are aesthetically pleasing with class-leading performance and innovative features. We utilise leading edge design techniques and technical skills to continuously improve our products and to ensure we consistently exceed the expectations of those who fabricate, specify and install our windows and doors.

Technology

Spectus is committed to continuous investment in technology in order to provide specifiers with a wider choice of products.

Precision

All Spectus products are designed and manufactured to bring precision technology and factory fit standards to the site.

ELITE 70

Elite 70 is a fully post co-extruded suite of profiles, available with either bevelled or ovolo aesthetics, which can be used to make casement windows, tilt & turn windows, entrance doors, french doors and Bi-Folding doors.

Reversible 70

Reversible 70 can be used to make fully reversible windows & fixed lights. A wide range of profiles allows multi-light configurations to be accommodated. The edge detail is common with Elite 70 making it ideal for coupling with both the Elite 70 and Patio systems.

ELITE 63

Elite 63 is a fully post co-extruded chamfered system which also offers the alternative of ovolo casement windows. It can also be used to make tilt & turn windows, entrance doors, french doors and Bi-Folding doors.

VERTICAL SLIDER

The vertical slider is an ovolo decorative system offering all the benefits of modern technology in a system ideally suited to both modern and period style properties.

RIDE OVER PATIO

The ride over patio offers a chamfered detail with a 70mm wide frame making it ideal for coupling with both the Elite 70 and Reversible 70 systems.

FORMER

The Spectus Former is an integrated Acceptor, Former, Closer and DPC available in a variety of widths with standard and check reveal options to suit building construction.

CURTAIN WALLING

The curtain walling system allows the construction of many different styles and sizes off curtain walling and will accommodate both 70mm and 63mm profiles



INTRODUCTION - ACCREDITATION

REGULATIONS & STANDARDS

Spectus windows and doors conform to the following statutory requirements, British Standards and BBA Approvals or Trade Standards:

Building Regulations

- The Building Regulations (England and Wales)
- The Building Standards (Scotland) Regulations
- The Building Regulations (Northern Ireland)
- The Building Regulations (Ireland)

Accreditation

The table below shows the accreditation status of Spectus Window Systems products :-

- BS EN 12608: - Specifications for plastic windows made from PVC-U extruded hollow profiles.
- BS 7412: - Plastic windows made from PVC-U extruded hollow profile
- BS 7950: - Improved security and performance of domestic windows.
- PAS 23: - General performance requirements for door assemblies (Single leaf only)
- PAS 24: - Enhanced security performance requirements for door assemblies (Single leaf only)
- BBA: - British Board of Agreement assessment

Glass and Glazing

Glass and sealed units (when fitted as recommended) should comply with:

- BS 952: Part 1 - classification of glass for glazing.
- BS 5713: - specification for hermetically sealed flat double glazing units.
- BS 6206: - specification for impact performance requirements for flat safety glass and safety plastics for use in buildings.
- BS 6262: - code of practice for glazing for buildings.

Reinforcement

Steel reinforcement, where used, complies with BS EN 10346 :- Continuously hot-dip coated steel flat products. Technical delivery conditions

Aluminium reinforcement, where used, complies with BS EN 485-2, BS EN 515 or BS EN 755-9, as laid down in BS 7412.

System	Product	BSEN12608	BS7412	BS7950	PAS23	PAS24	BBA
Elite 70	Casement	•	•	•			•
	Tilt & Turn	•	•	•			•
	Door	•			•	•	
Elite 63	Casement	•	•	•			•
	Tilt & Turn	•	•	•			•
	Door	•			•	•	
Reversible 70	Reversible	•	•	•			•
Vertical Slider	Sash window	•	•	•			•
Former	Cavity Closer						•

Spectus profiles are manufactured under a quality assurance system which conforms to BS EN ISO 9001:2008



INTRODUCTION - SIZE LIMITATIONS

CASEMENT WINDOWS

The tables below show the minimum and maximum dimensions for common window styles using Intermediate Outer Frame & Slim Transom/Mullion.

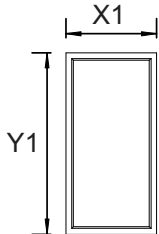

Dimension	Min	Max
X1	300	3000
Y1	300	3000

SIDE HUNG EXAMPLES

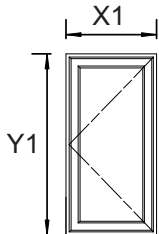

Dimension	Min	Max
X1	364	764
Y1	364	1364
X1 (ALT.)	364	714
Y1 (ALT.)	364	1464

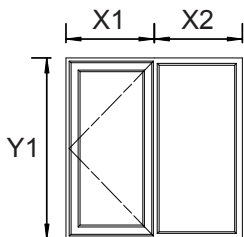

Dimension	Min	Max
X1	337	737
X2	335	2663
Y1	364	1364

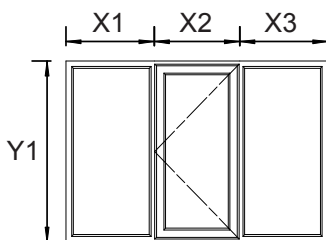

Dimension	Min	Max
X1	335	2355
X2	310	710
X3	335	2355
Y1	364	1364

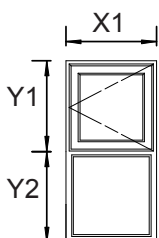

Dimension	Min	Max
X1	364	764
Y1	337	1337
Y2	335	2663

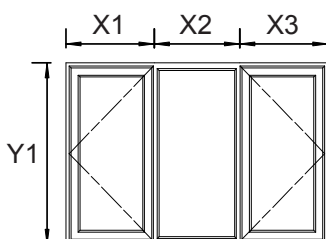

Dimension	Min	Max
X1	337	737
X2	335	2326
X3	337	737
Y1	364	1364

MAXIMUM VENT SIZES

SIDE HUNG VENT

Maximum Width = 700mm
 Maximum Height = 1300mm
 or
 Maximum Width = 650mm
 Maximum Height = 1400mm

TOP HUNG VENT

Maximum Width = 1200mm
 Maximum Height = 1200mm

*NOTES:

Overall maximum window dimension should not exceed 3000mm in any direction.

Smaller sash sizes may be possible but are dependant on machinery & hardware limitations.

TOP HUNG EXAMPLES

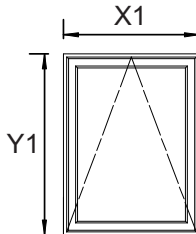

Dimension	Min	Max
X1	364	1264
Y1	364	1264

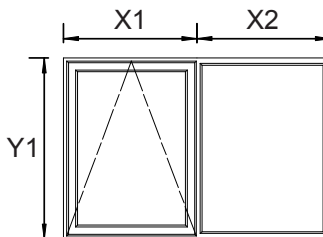

Dimension	Min	Max
X1	337	1237
X2	335	2663
Y1	364	1264

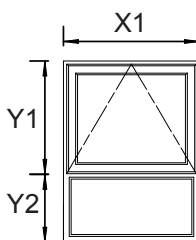

Dimension	Min	Max
X1	364	1264
Y1	337	1237
Y2	335	2663

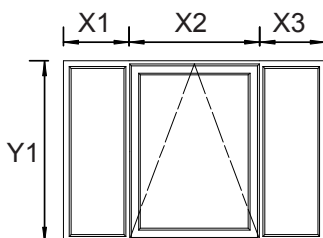

Dimension	Min	Max
X1	335	2355
X2	310	1210
X3	335	2355
Y1	364	1264

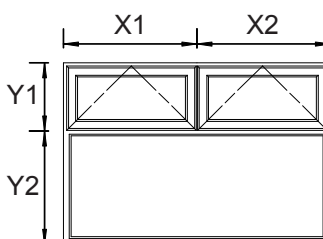

Dimension	Min	Max
X1	337	1237
X2	337	1237
Y1	337	1237
Y2	335	2663

Note: To determine the required transom & mullion to suit the windload see pages Gen.2 - Gen.8



INTRODUCTION - SIZE LIMITATIONS

TILT & TURN WINDOWS

The tables below show the minimum & maximum dimensions for common tilt & turn window styles using Large Outer Frame, Intermediate Transom/Mullion and Tilt & Turn Sash

MAXIMUM VENT SIZES

Maximum Vent Width = 1500mm
Maximum Vent Height = 1500mm

Note: The vent width must not exceed 1.5 times the height.

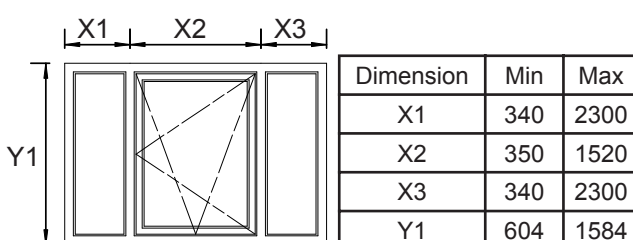
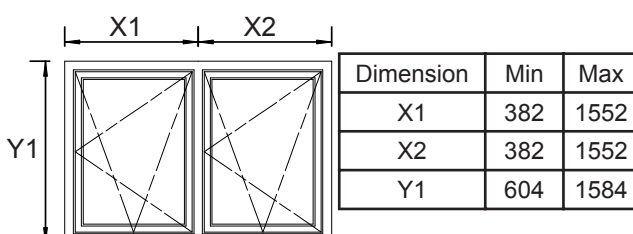
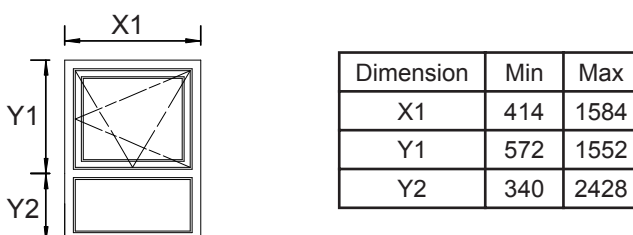
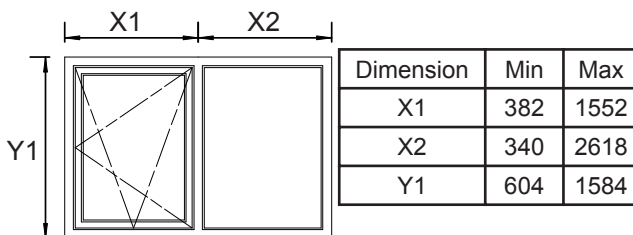
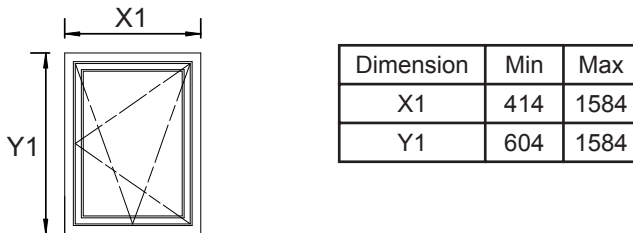

REVERSIBLE

The tables below show the minimum & maximum dimensions for common reversible window styles using SW702/SW781 Outer Frame, SW782/SW784 Mullion and SW780 Sash

MAXIMUM VENT SIZES

Maximum Vent Width = 1500mm
Maximum Vent Height = 1514mm
Maximum Vent Weight = 60kg

Note: The vent height must exceed the width.

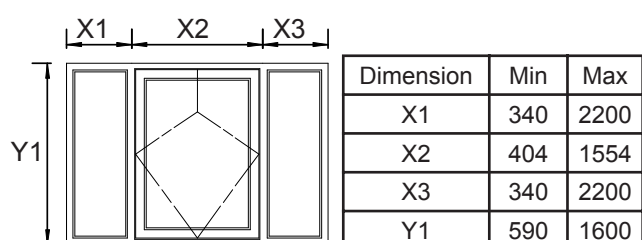
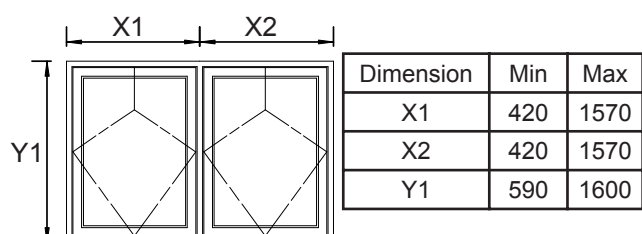
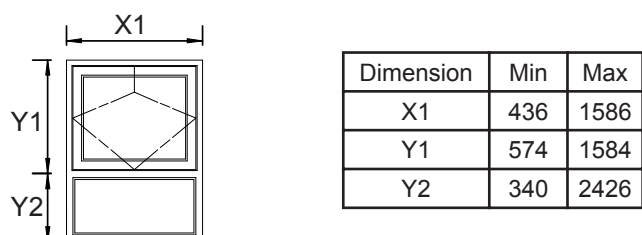
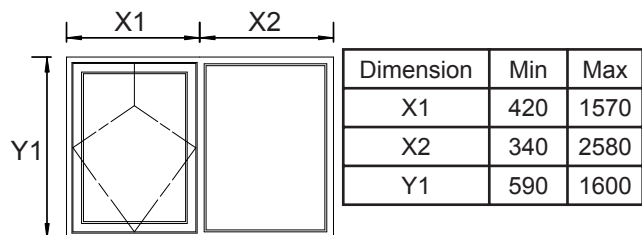
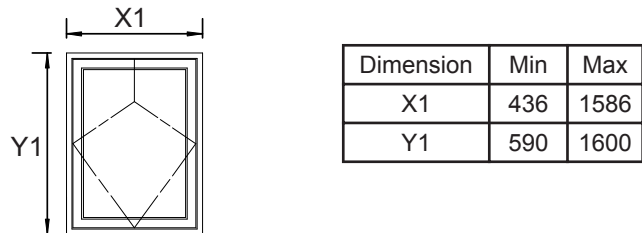

Note: To determine the required transom & mullion to suit the windload see pages Gen.2 - Gen.8



INTRODUCTION - SIZE LIMITATIONS

DOORS

The tables show the minimum & maximum dimensions for door styles using Large Outer Frame, Large Mullion and Door Sash

SINGLE LEAF DOORS

Maximum Leaf Width = 1000mm
Maximum Leaf Height = 2200mm

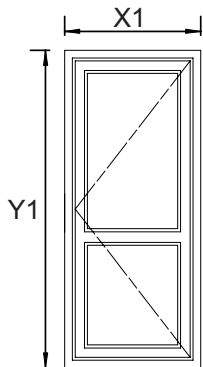

Dimension	Min	Max
X1	500	1084
X1 (Letterplate)	700	1084
Y1	1900	2284

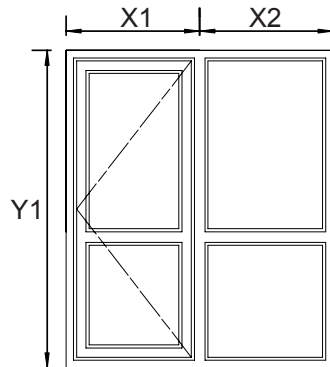

Dimension	Min	Max
X1	500	1069
X2	340	2500
X2 (Midrail)	340	2500
X2 (Letterplate)	700	2500
Y1	1900	2284

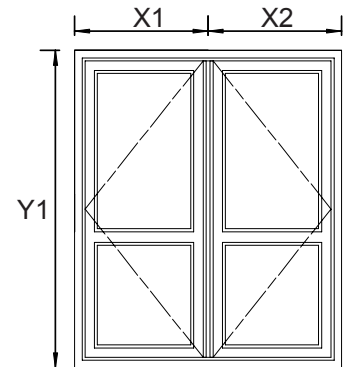

Dimension	Min	Max
X1	500	1047
X2	500	1047
Y1	1900	2284

BI-FOLDING DOORS

Maximum Leaf Width = 900mm
Maximum Leaf Height = 2400mm
Minimum Leaf Width = 600mm
Minimum Leaf Height = 840mm

Maximum Vent Weight = 80 Kg

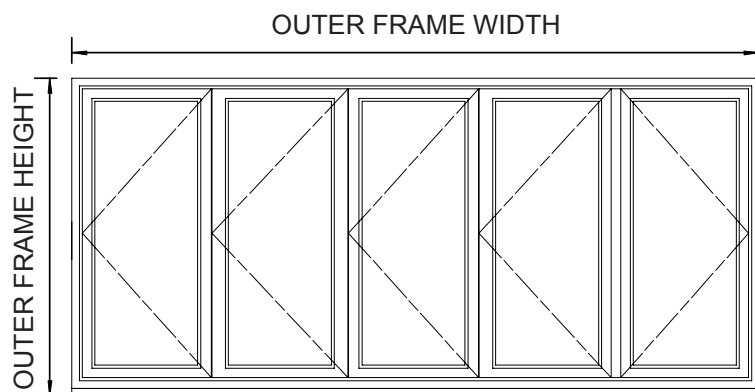

***NOTES:**

Overall maximum frame dimensions, for each pane number, can vary slightly dependant on the actual scheme chosen

Smaller sash sizes may be possible but are dependant on machinery & hardware

No. of panes	Maximum outer frame width	Maximum outer frame height	Minimum outer frame height
2	1855mm	2534mm	974mm
3	2778mm	2534mm	974mm
4	3662mm	2534mm	974mm
5	4546mm	2534mm	974mm
6	5430mm	2534mm	974mm
7	5995mm	2534mm	974mm

Note: Deduct 25mm from the overall height if a low threshold is used (applicable to single leaf & French doors only)



INTRODUCTION - SIZE LIMITATIONS

VERTICAL SLIDER

Maximum Sash Weight :50kg

Maximum Sash Weight for tilt applications :35kg

Maximum Window sizes for given wind loads :

The two graphs below show the maximum overall dimensions of windows with given windloadings.

1. For normal/standard applications, use the 1200 Pascals curve.

2. For more critical/heavy duty applications, the specific wind pressure can be derived using BS 6375: Part 1, and used with the relevant curve below.

Standard Configuration :

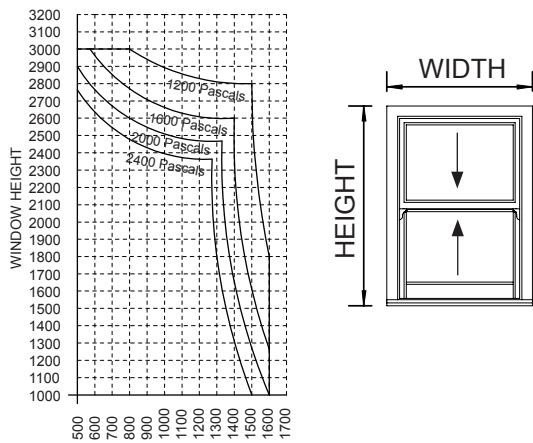

Heavy Duty Configuration

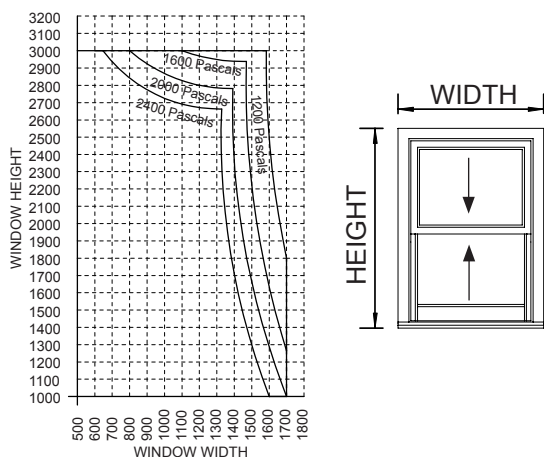

Minimum Window Heights

Based on Caldwell Spiral Balance 203mm
Window Height = 700mm. Sash height = 310mm

Based on Caldwell Ultralift Balance 317mm
Window Height = 880mm. Sash height = 400mm
Minimum Sash Weight = 6kg

RIDE OVER PATIO

The maximum and minimum sizes are shown below.

2 PANE PATIO
WIDTH

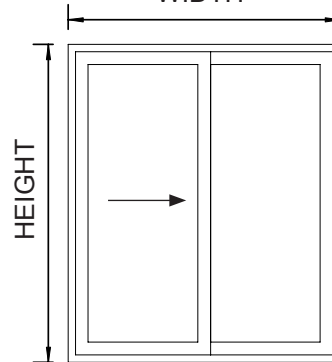

HEIGHT	Max 2400mm	Min 1400mm
WIDTH	Max 3000mm	Min 1490mm

3 PANE PATIO
WIDTH

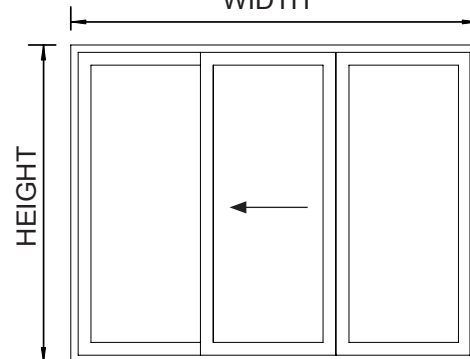

HEIGHT	Max 2400mm	Min 1400mm
WIDTH	Max 4400mm	Min 2230mm

4 PANE PATIO
WIDTH

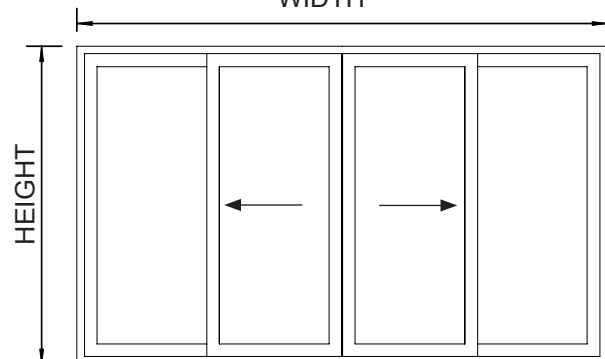

HEIGHT	Max 2400mm	Min 1400mm
WIDTH	Max 4600mm	Min 2890mm



INTRODUCTION - REINFORCEMENT

REINFORCEMENT

Spectus Window Systems aluminium or steel reinforcement must be used where applicable, and in all cases, reinforcement should be continuous and unbroken, otherwise any **Spectus Window Systems** warranty will be invalidated.

Re-cycled PVC-U thermal & mechanical inserts are available for certain non-structural applications.

Recommended minimum reinforcement requirements for white & foiled profiles are as follows :

WINDOW OUTER FRAMES

- In the head of all outer frames where the width exceeds 1350mm.
- In all vertical outer frame members of all bay window segments.
- In the vertical outer frame members of all coupled frames.
- In the vertical outer frame members of all reversible windows adjacent to an opening vent.
- In the head and jambs of all outer frame members of vertical sliding windows.

WINDOW TRANSOMS / MULLIONS

- In all transoms/mullions where the length exceeds 1000mm (*600mm for foiled profile*).
- In all mullions of reversible windows adjacent to an opening vent.
- On cruciform joints where the transom and mullion both exceed 1000mm (*600mm for foiled profile*), the reinforcement should be unbroken in the shorter member. The other member should then only be reinforced in any section that exceeds 1000mm (*600mm for foiled profile*).
- In all members to be mechanically jointed.
- In all transoms/mullions spanning from outer frame to another transom/mullion, between opening vents, where the length exceeds 600mm.

CASEMENT VENTS

- In all members forming the widths of side hung vents where the width exceeds 600mm.
- In all members forming the jambs of side hung vents where the height exceeds 1000mm (*600mm for foiled profile*).
- In all members forming the widths of top hung vents where the width exceeds 1000mm (*600mm for foiled profile*).
- In all members forming the jambs of top hung vents where the height exceeds 1000mm (*600mm for foiled profile*).

TILT & TURN VENTS

- In all members forming the widths of tilt & turn vents where the width exceeds 1000mm (*600mm for foiled profile*).
- In all members forming the jambs of tilt & turn vents where the height exceeds 1000mm (*600mm for foiled profile*).

REVERSIBLE VENTS

- In all members forming the widths of reversible vents where the width exceeds 600mm.
- In all vertical members of reversible vents.

VERTICAL SLIDER SASHES

- In all sash members.

DOOR OUTER FRAMES

- In the head of all outer frames where the width exceeds 1350mm.
- In the cill of outer frame members adjacent to an opening vent.
- In all vertical outer frame members adjacent to an opening vent.
- In the vertical outer frame members of all coupled frames.

DOOR TRANSOMS / MULLIONS

- In all transoms/mullions where the length exceeds 1000mm (*600mm for foiled profile*).
- In all members to be mechanically jointed.

DOOR LEAFS

- In all members forming the jambs of door vents.
- (*In all members forming the widths of door vents where the width exceeds 600mm for foiled profile.*)



ELITE 70 - PROFILE GUIDE

OUTER FRAMES

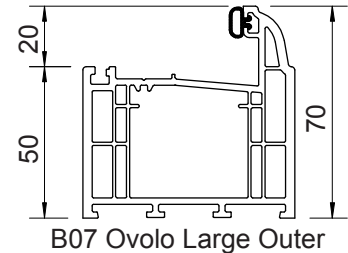
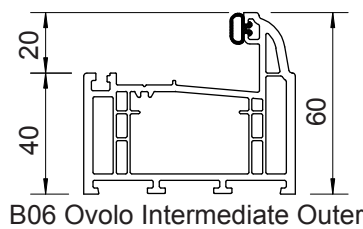
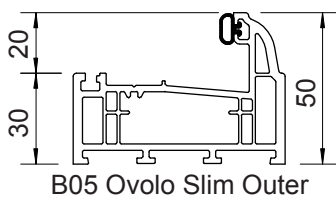
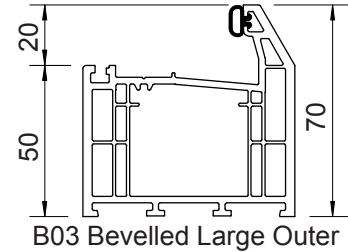
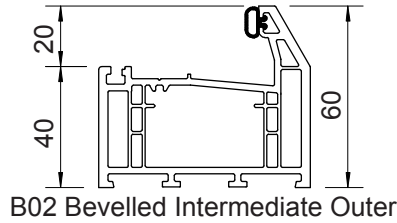
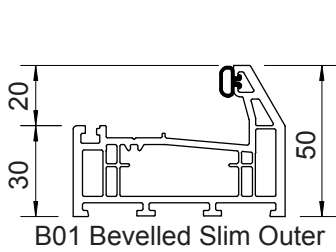

TRANSOMS/MULLIONS

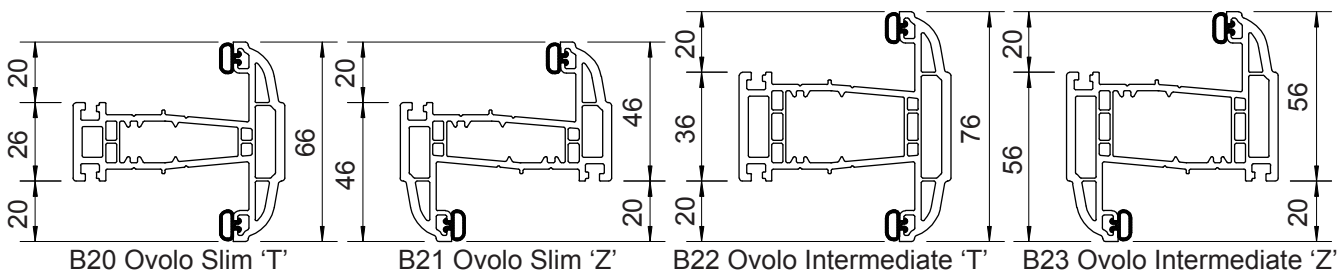
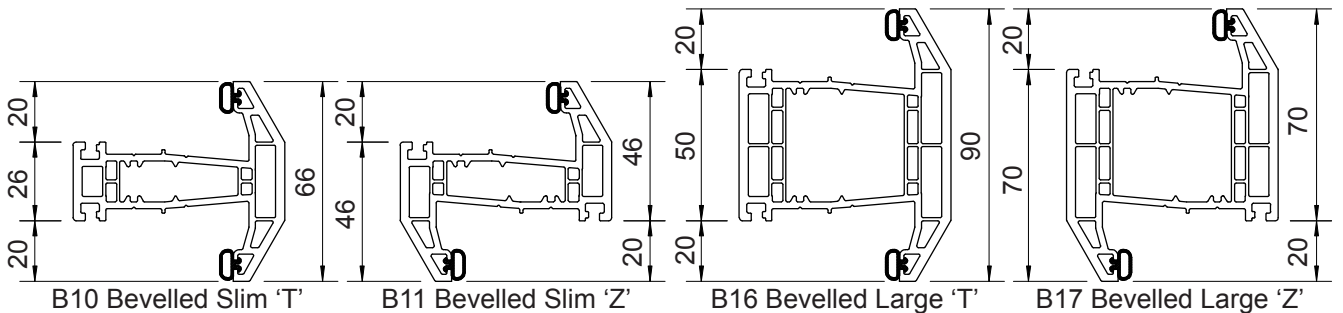

CASEMENT SASHES

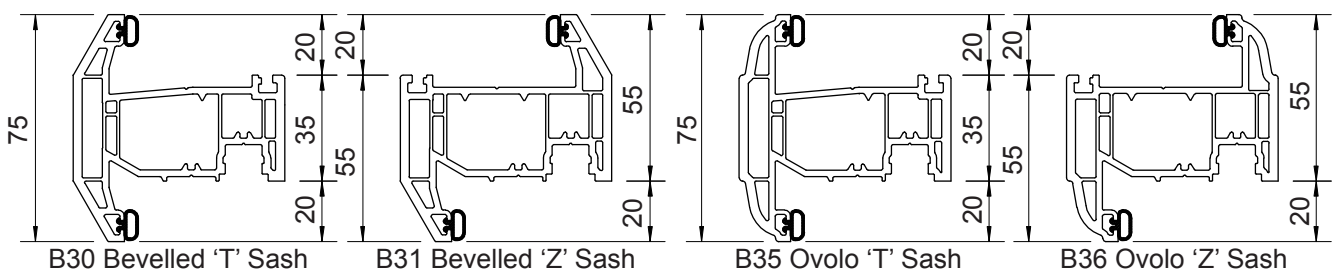



ELITE 70 - PROFILE GUIDE

MIDRAILS/MULLIONS

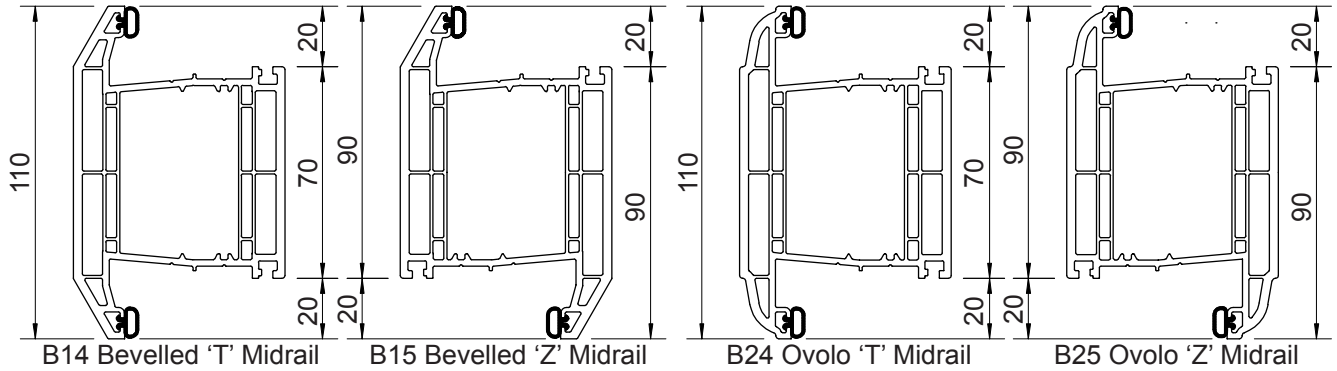

DOOR SASHES

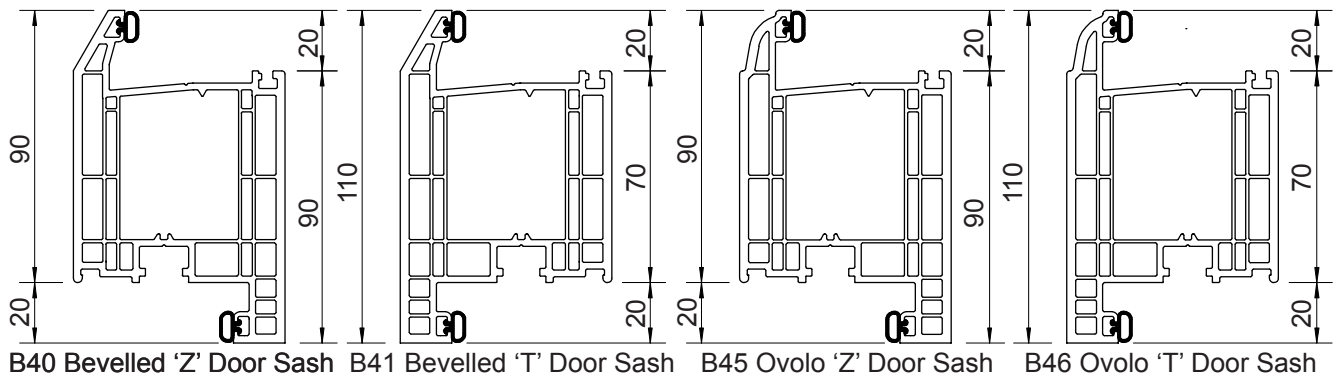

TILT & TURN SASHES

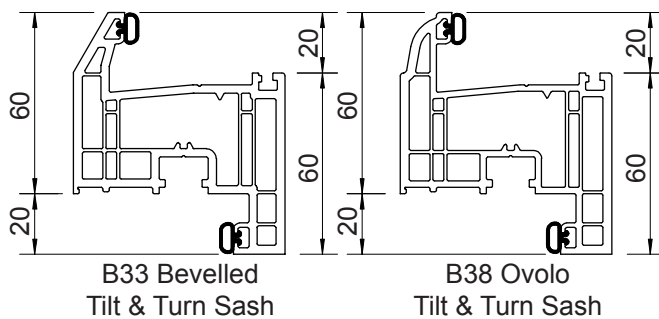

ANCILLARIES

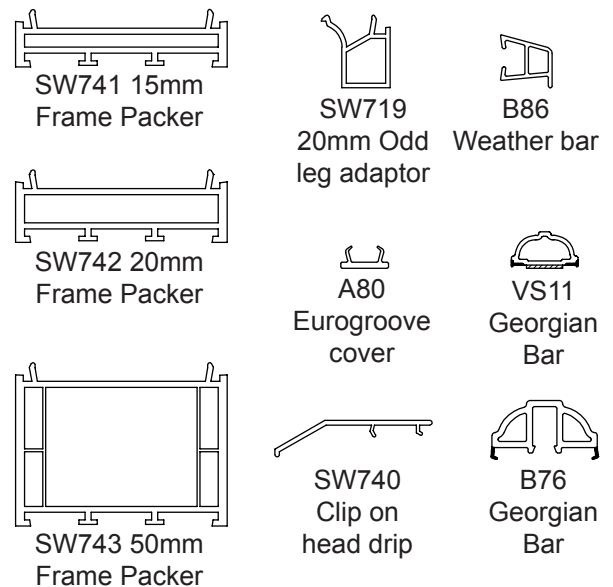

GLAZING BEADS

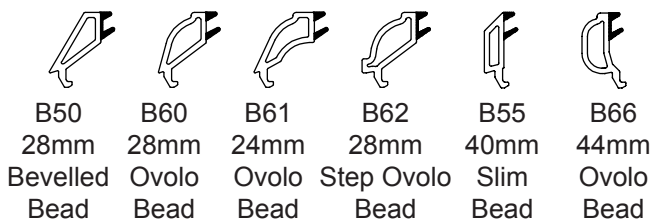



ELITE 70 - PROFILE GUIDE

BAY COUPLINGS

B70 Bay Pole

B72 135° Bay Post

B73 150° Bay Post

SW39 Bay Cover Strip

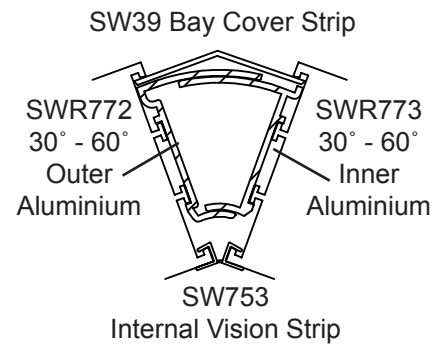
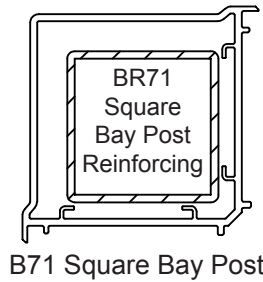
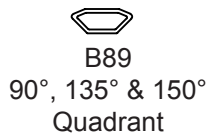
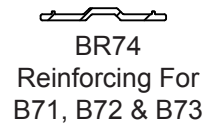
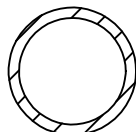
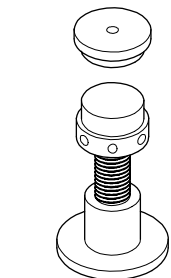
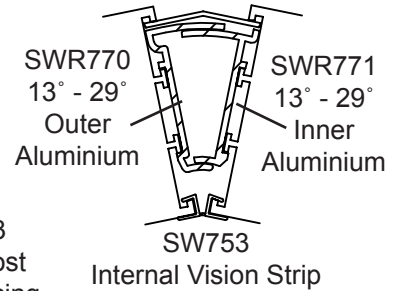
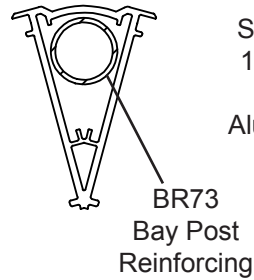
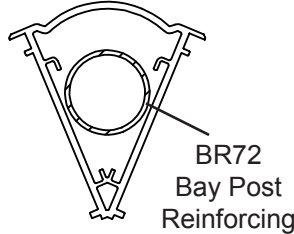
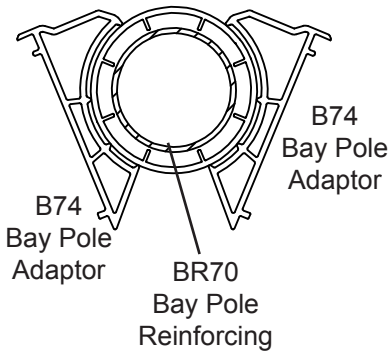

COUPLING MULLIONS

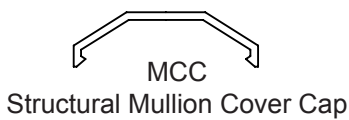

SW58 Ovolo Coupling Mullion Cover Cap

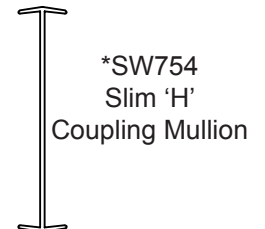
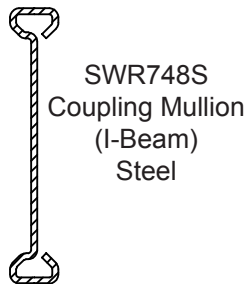
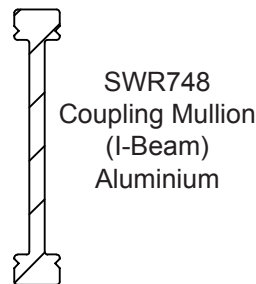
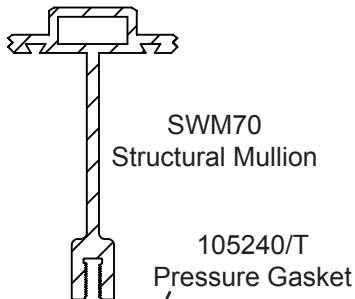



ELITE 70 - GENERAL ASSEMBLIES

INTERNALLY BEADED CASEMENT (BEVELLED)

TYPICAL OPEN-OUT CASEMENT WINDOW

SPECIFICATION

Intermediate Outer Frame
Slim 'Z' Transom
'T' Section Sash
28mm Bevelled Glazing Bead
150mm Cill
Steel Reinforcing

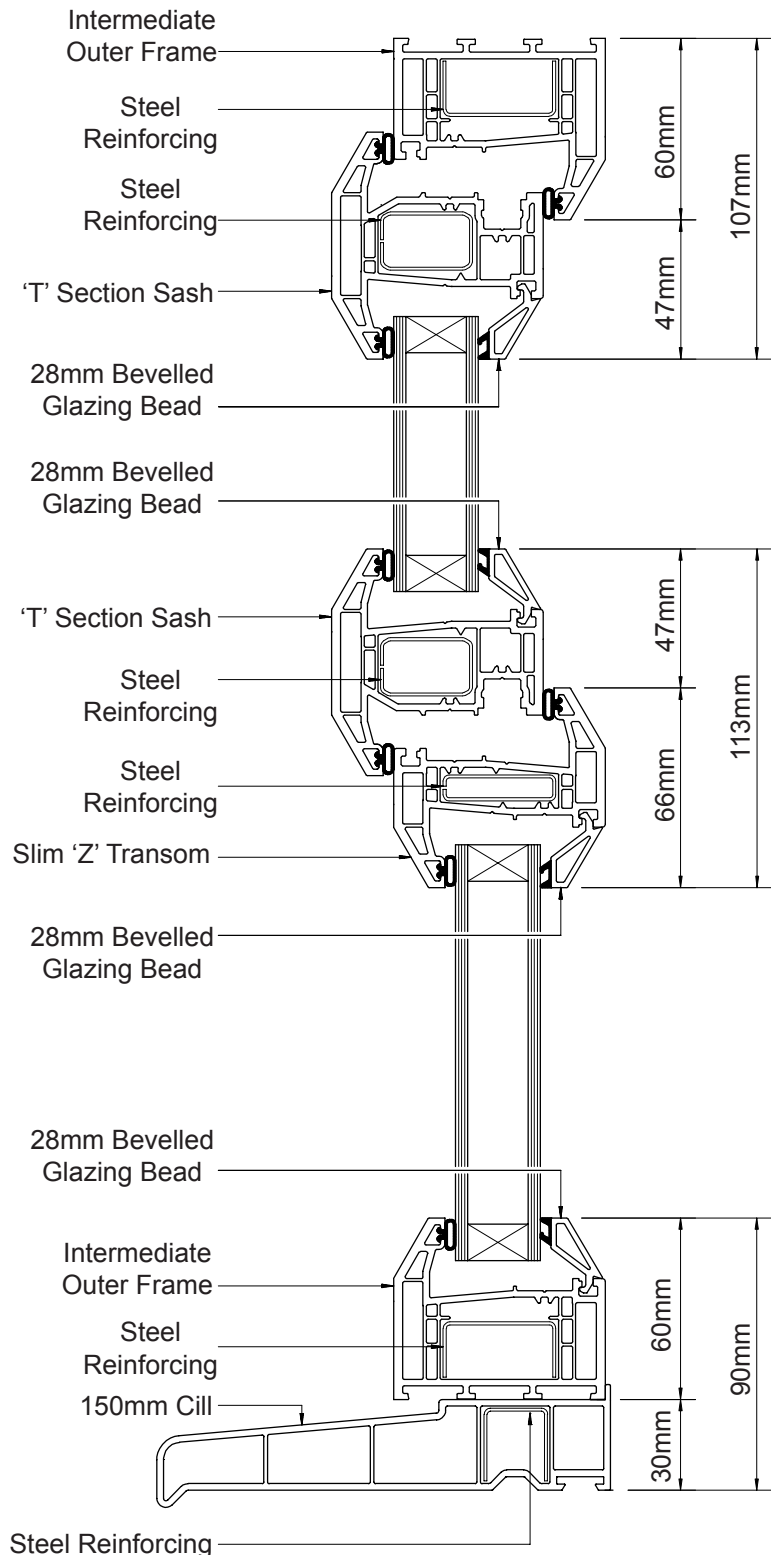
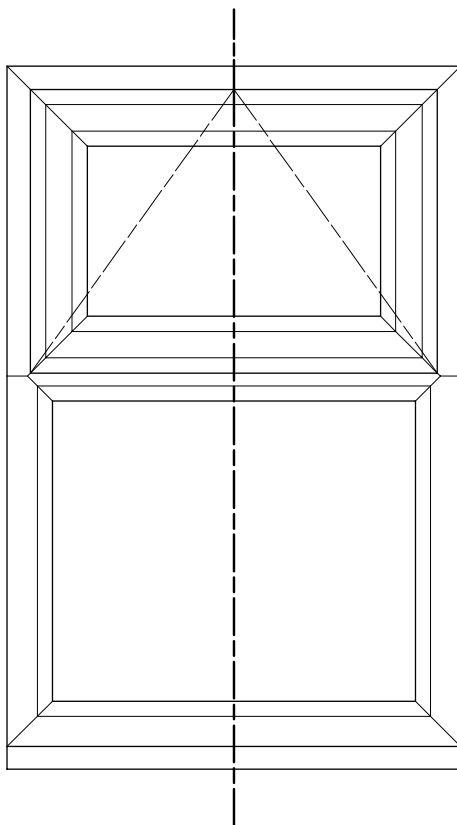

Note : All reinforcements shown are for diagramatical purposes only. For application, see pages Int.7 & Gen.5



ELITE 70 - GENERAL ASSEMBLIES

INTERNALLY BEADED CASEMENT (OVOLO)

TYPICAL OPEN-OUT CASEMENT WINDOW

SPECIFICATION

Intermediate Outer Frame
Slim 'Z' Transom
'T' Section Sash
24mm Ovolo Glazing Bead
180mm Cill
Aluminium Reinforcing

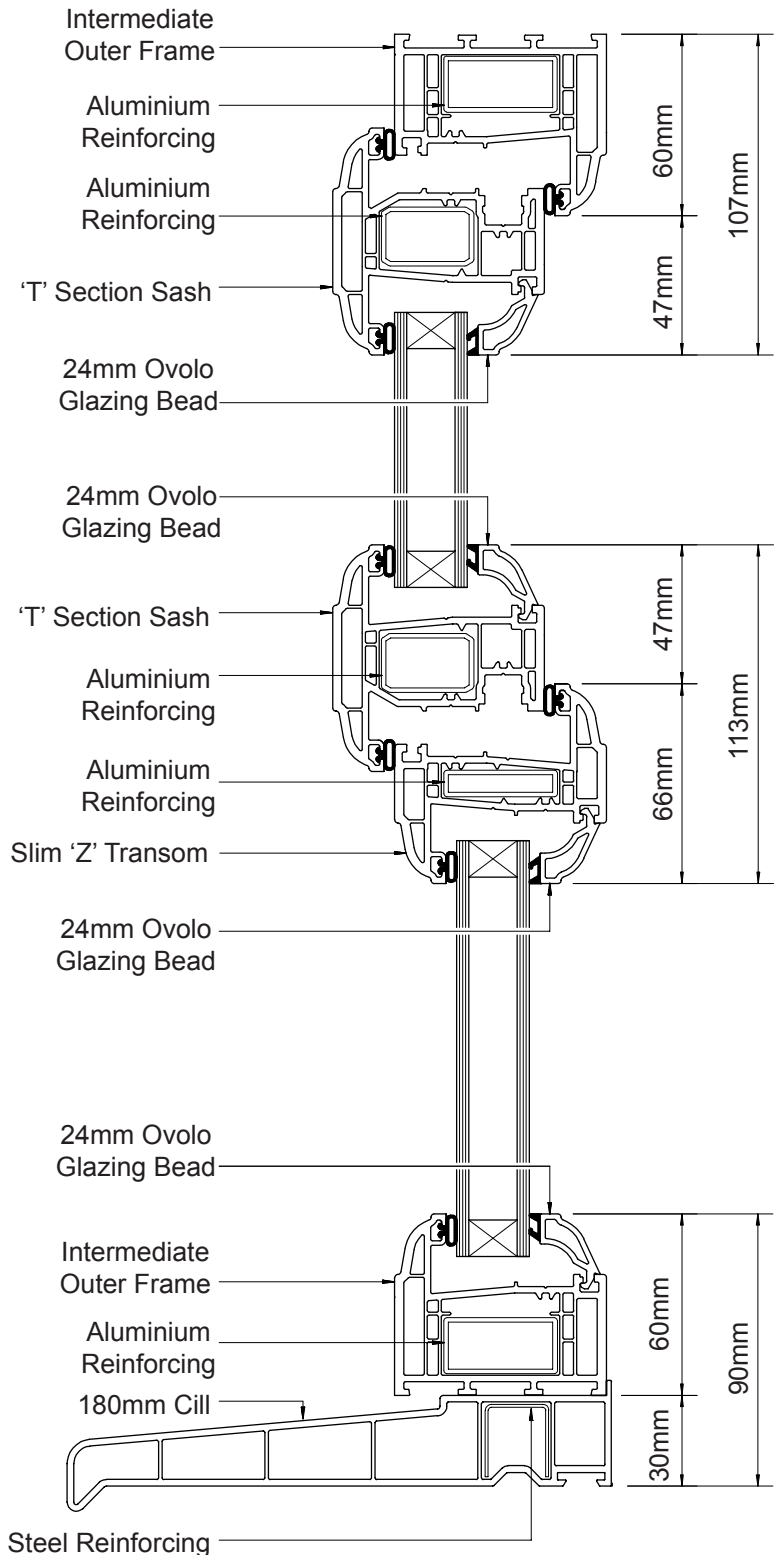
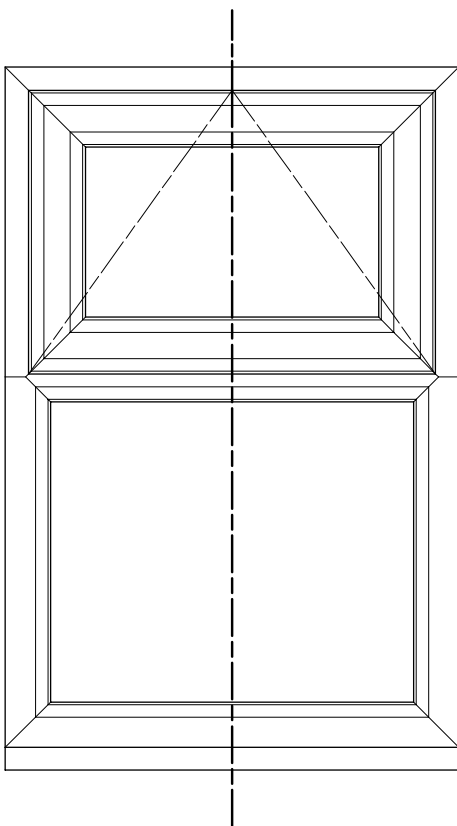

Note : All reinforcements shown are for diagramatical purposes only. For application, see pages Int.7 & Gen.5



ELITE 70 - GENERAL ASSEMBLIES

EXTERNALLY BEADED CASEMENT (BEVELLED)

TYPICAL OPEN-OUT CASEMENT WINDOW

SPECIFICATION

Slim Outer Frame
Slim 'T' Transom
'Z' Section Sash
28mm Bevelled Glazing Bead
180mm Cill
Aluminium Reinforcing

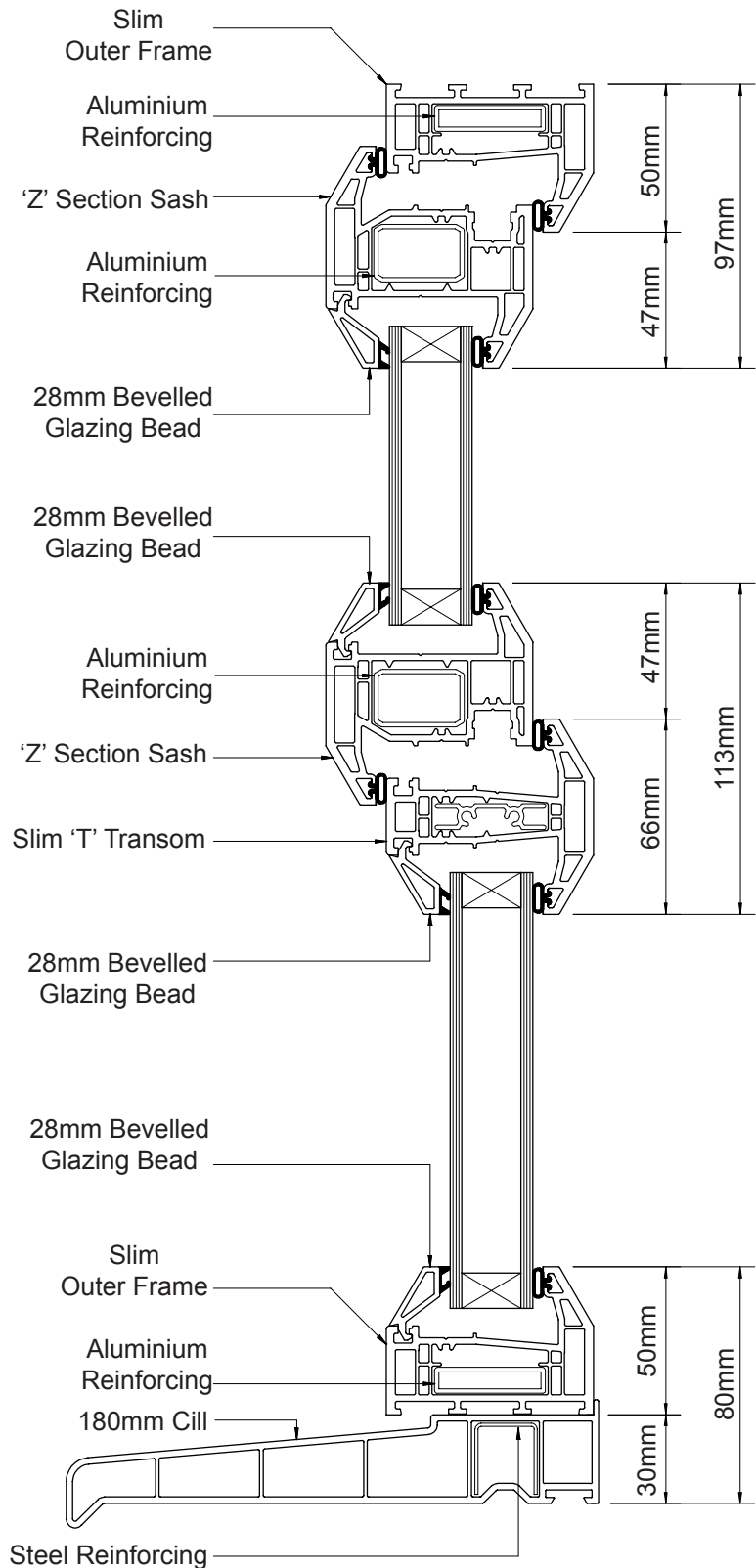
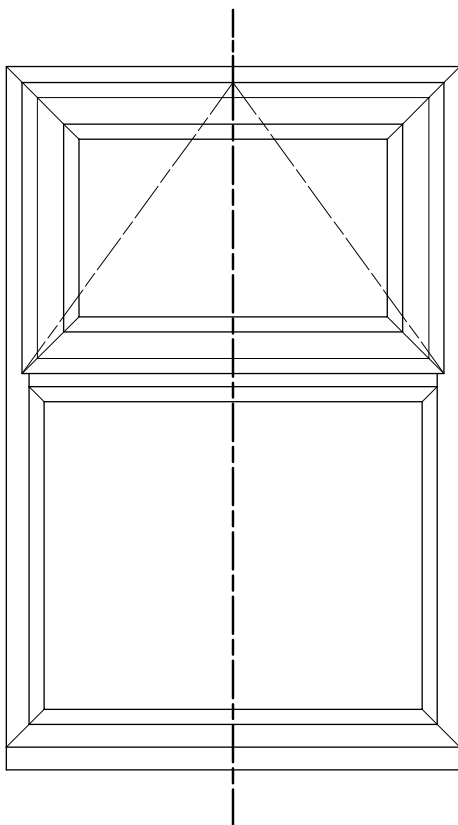

Note : All reinforcements shown are for diagrammatical purposes only. For application, see pages Int.7 & Gen.5



ELITE 70 - GENERAL ASSEMBLIES

EXTERNALLY BEADED CASEMENT (OVOLO)

TYPICAL OPEN-OUT CASEMENT WINDOW

SPECIFICATION

Slim Outer Frame
Slim 'T' Transom
'Z' Section Sash
28mm Ovolo Glazing Bead
150mm Cill
Steel Reinforcing

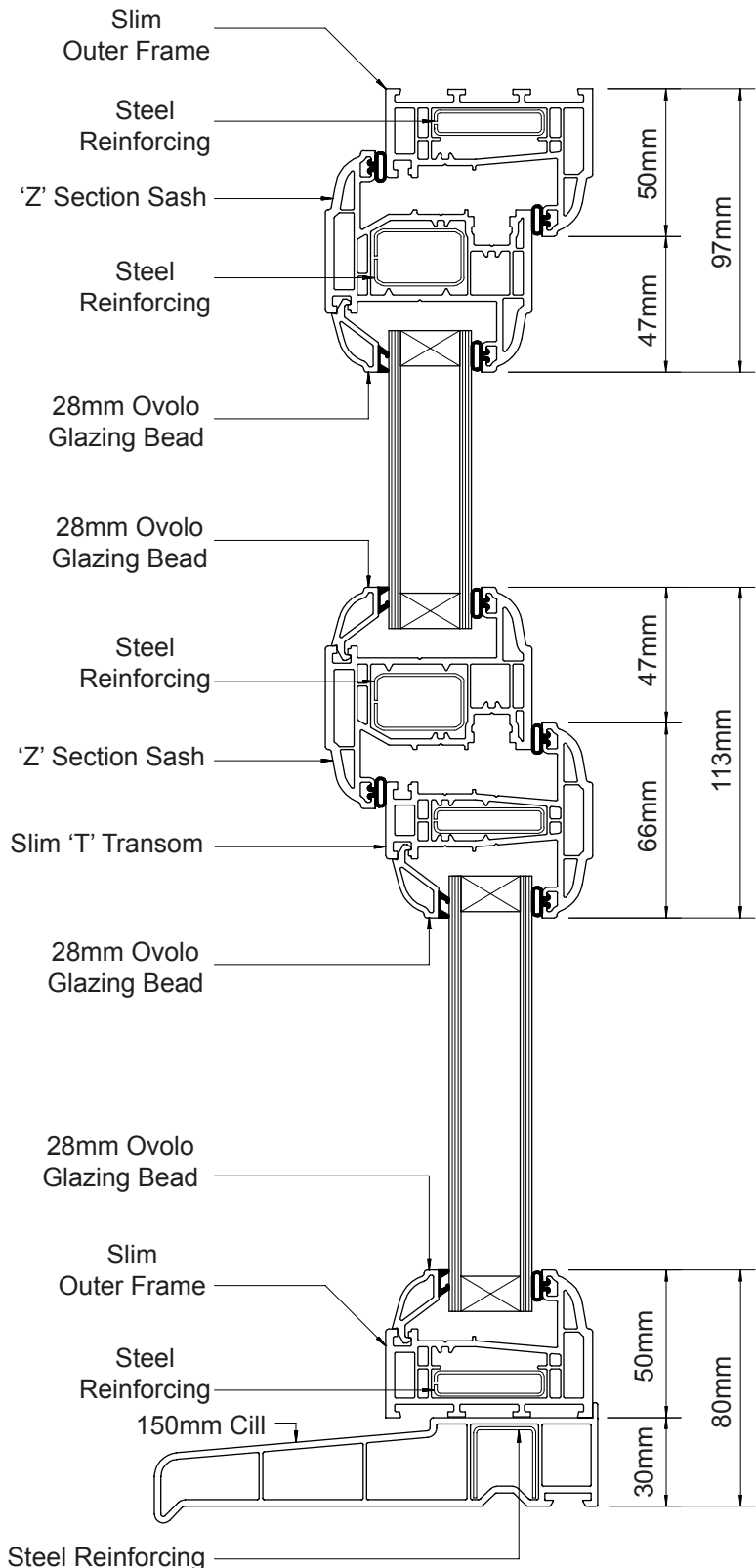
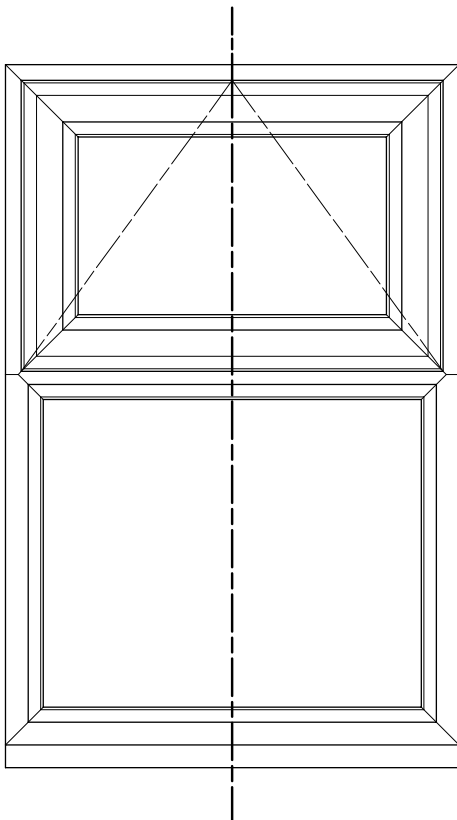

Note : All reinforcements shown are for diagramatical purposes only. For application, see pages Int.7 & Gen.5



ELITE 70 - GENERAL ASSEMBLIES

TILT & TURN WINDOW (BEVELLED)

TYPICAL OPEN-IN TILT & TURN WINDOW

SPECIFICATION

Large Outer Frame
Large 'T' Transom
'Z' Section Tilt & Turn Sash
28mm Bevelled Glazing Bead
150mm Cill
Steel Reinforcing

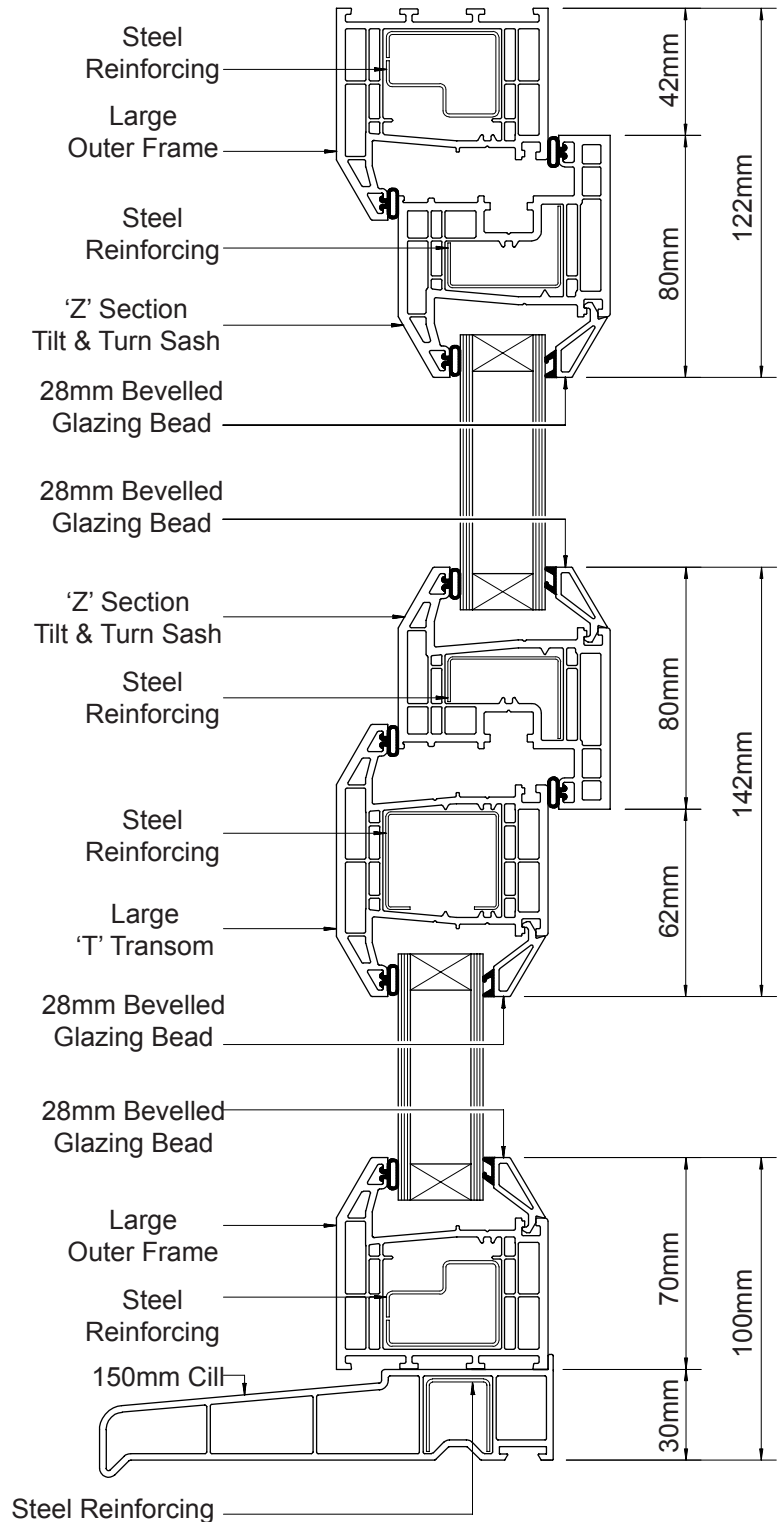
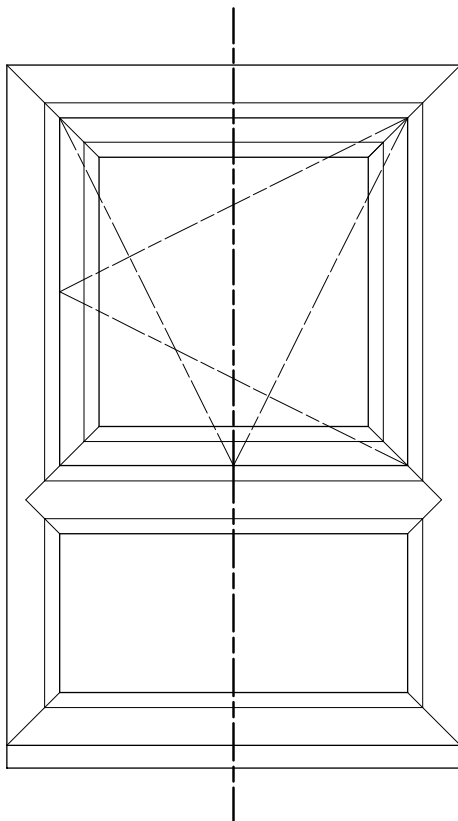

Note : All reinforcements shown are for diagramatical purposes only. For application, see pages Int.7 & Gen.5



ELITE 70 - GENERAL ASSEMBLIES

TILT & TURN WINDOW (OVOLO)

TYPICAL OPEN-IN TILT & TURN WINDOW

SPECIFICATION

Large Outer Frame
Intermediate 'T' Transom
'Z' Section Tilt & Turn Sash
24mm Ovolo Glazing Bead
85mm Cill
Steel Reinforcing

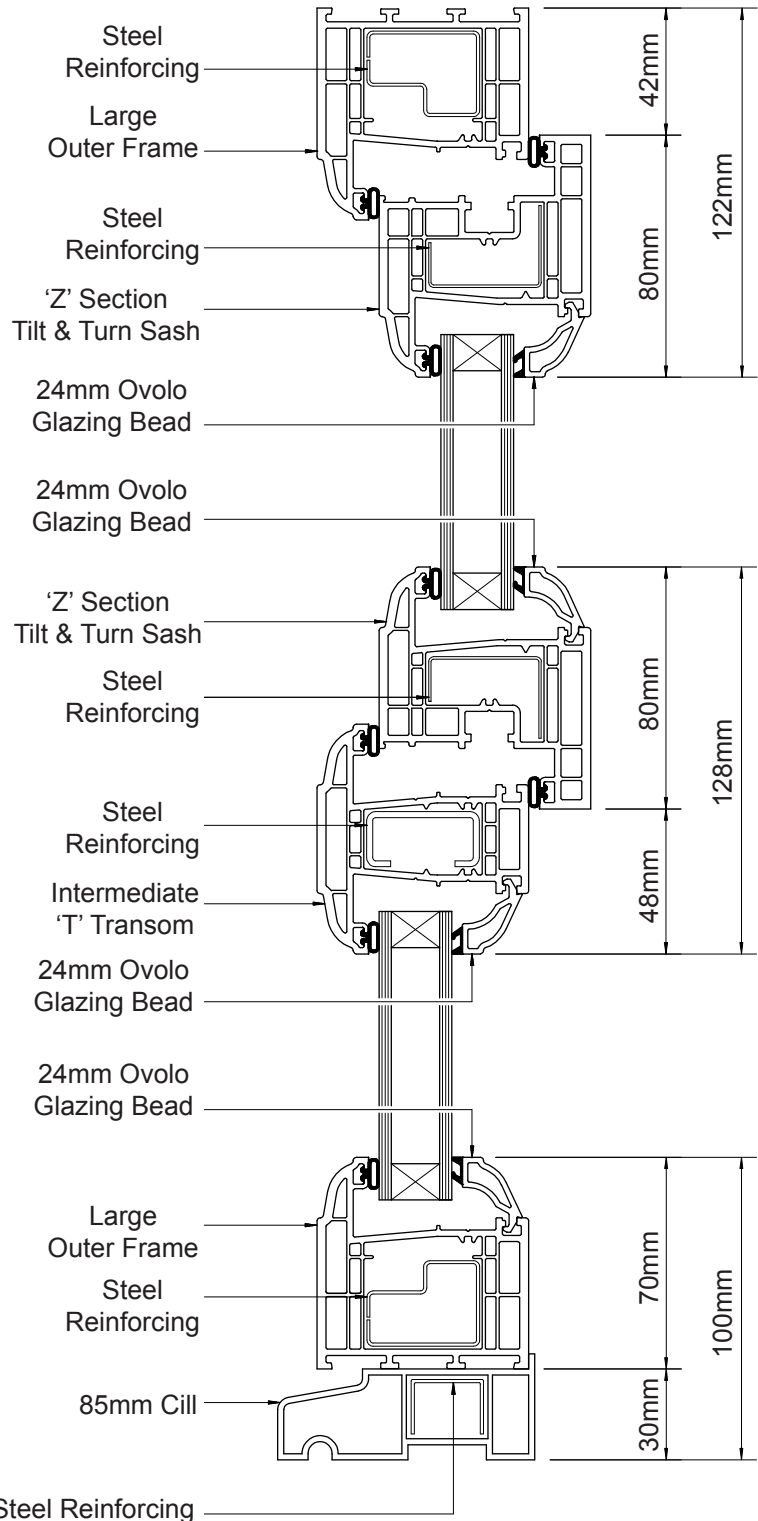
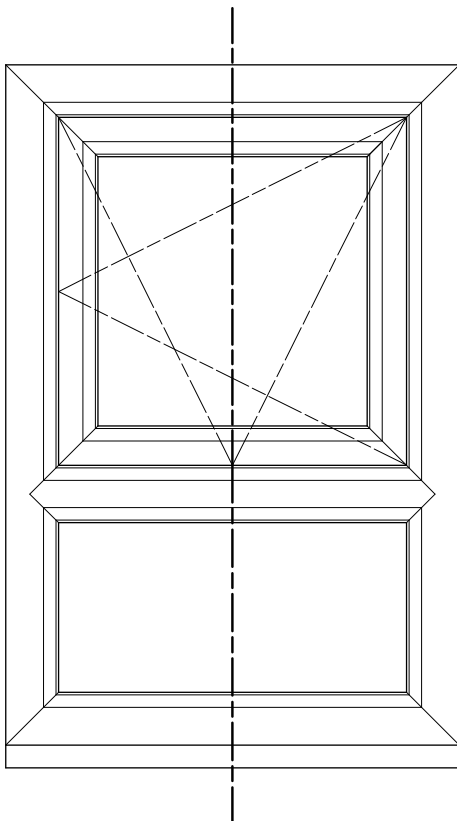

Note : All reinforcements shown are for diagramatical purposes only. For application, see pages Int.7 & Gen.5



ELITE 70 - GENERAL ASSEMBLIES

RESIDENTIAL DOOR (BEVELLED)

TYPICAL OPEN-IN RESIDENTIAL DOOR

SPECIFICATION

Large Outer Frame
'Z' Section Door Sash
'T' Section Midrail
28mm Bevelled Glazing Bead
Aluminium Low Threshold
Steel Reinforcing

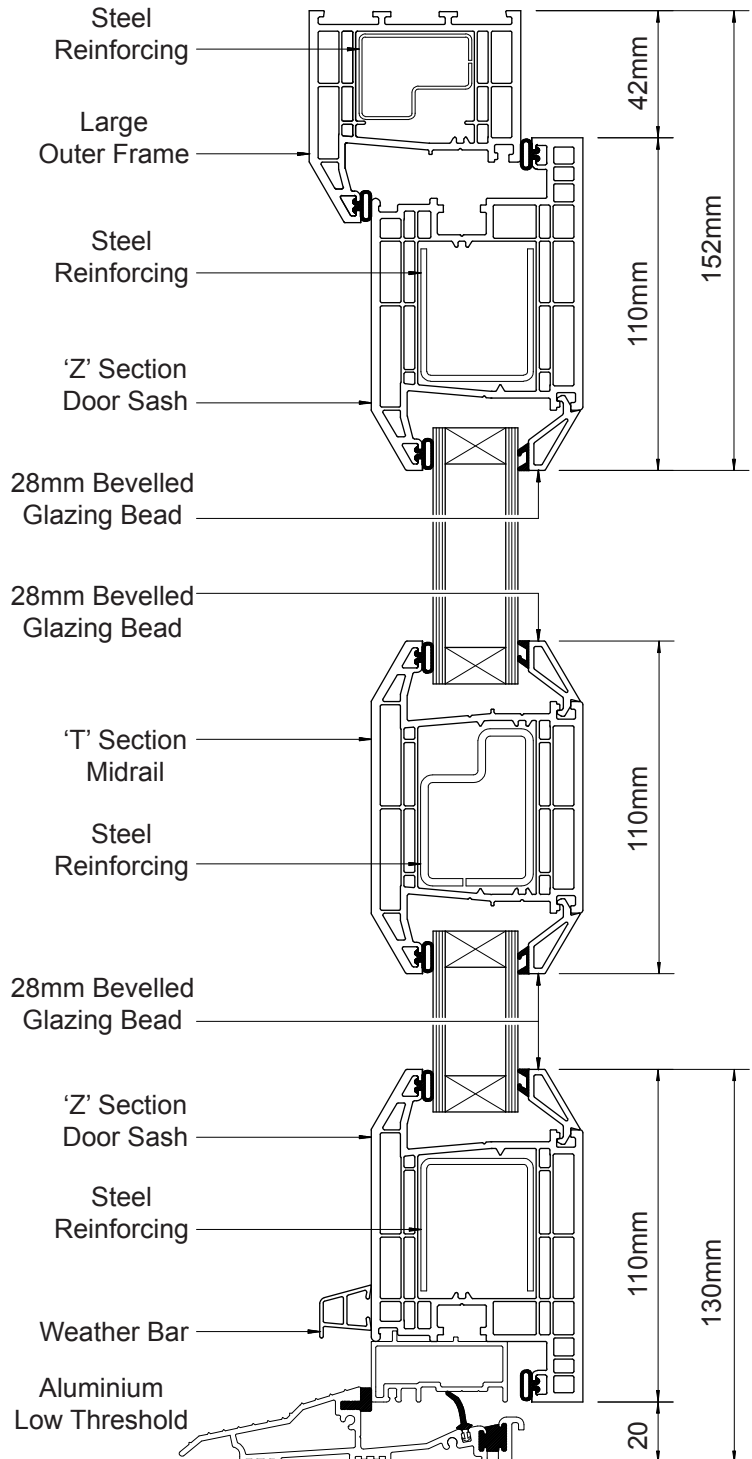
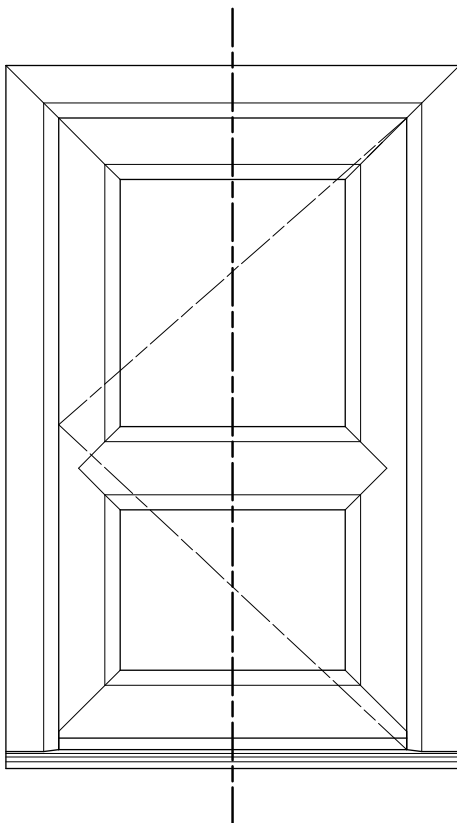

Note : All reinforcements shown are for diagramatical purposes only. For application, see pages Int.7 & Gen.5



ELITE 70 - GENERAL ASSEMBLIES

RESIDENTIAL DOOR (OVOLO)

TYPICAL OPEN-IN RESIDENTIAL DOOR

SPECIFICATION

Large Outer Frame
'Z' Section Door Sash
'T' Section Midrail
28mm Ovolo Glazing Bead
Aluminium Low Threshold
Steel Reinforcing

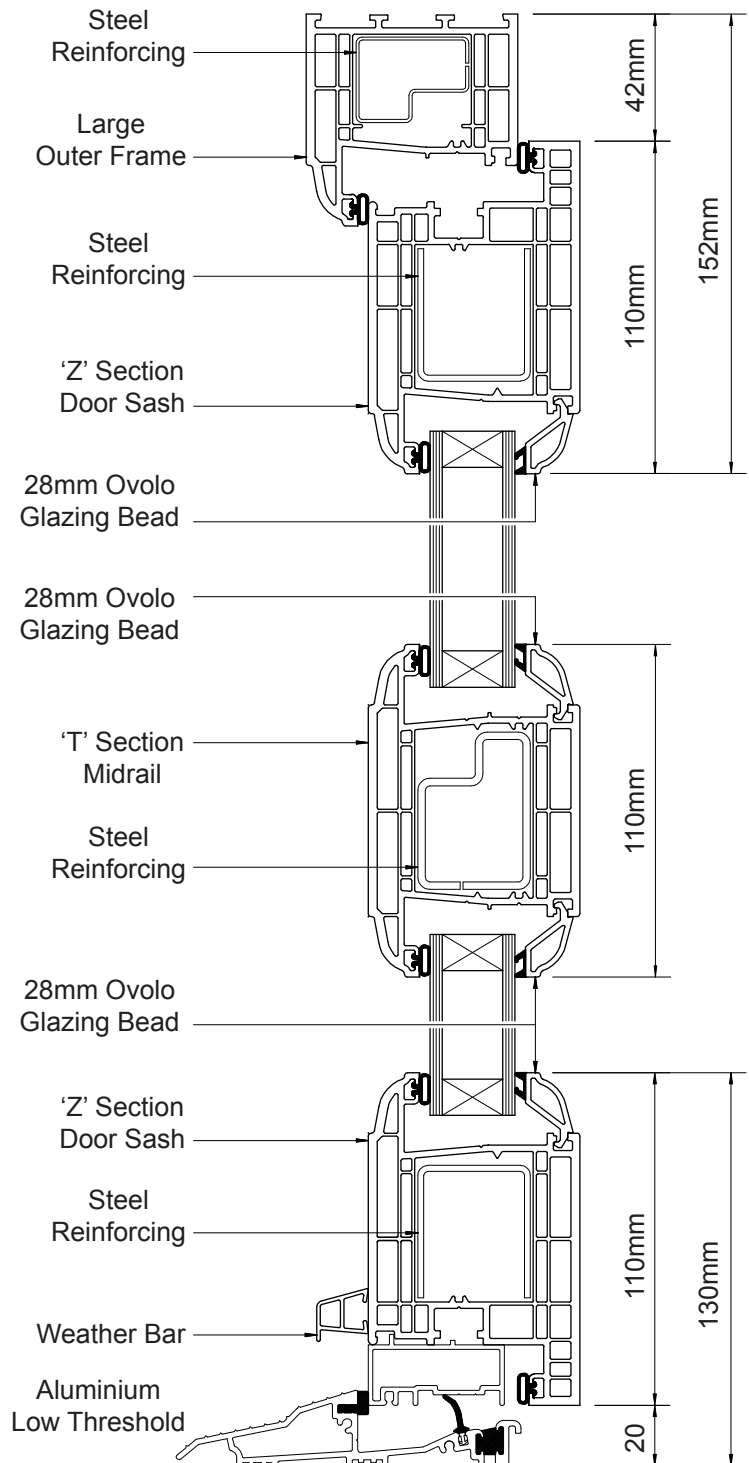
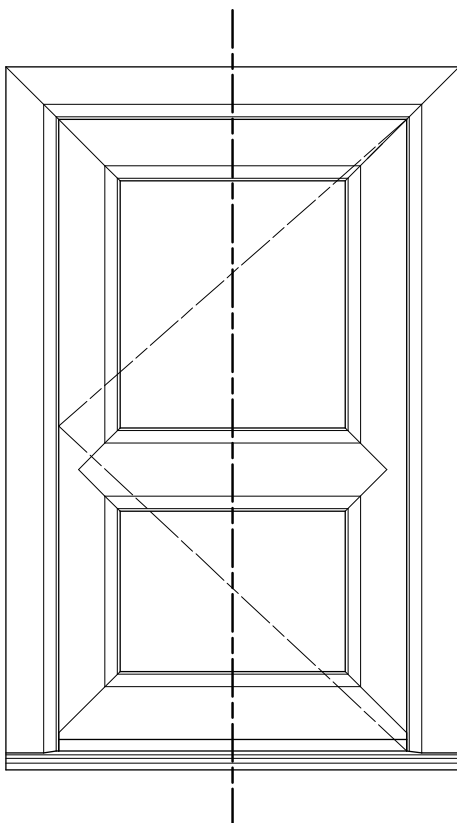

Note : All reinforcements shown are for diagrammatical purposes only. For application, see pages Int.7 & Gen.5



ELITE 70 - GENERAL ASSEMBLIES

RESIDENTIAL DOOR (BEVELLED)

TYPICAL OPEN-OUT RESIDENTIAL DOOR

SPECIFICATION

Large Outer Frame
'T' Section Door Sash
28mm Bevelled Glazing Bead
150mm Cill
Steel Reinforcing

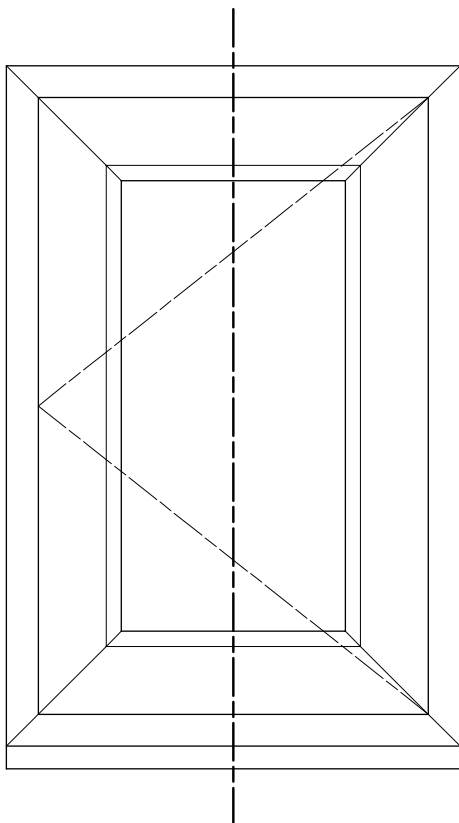
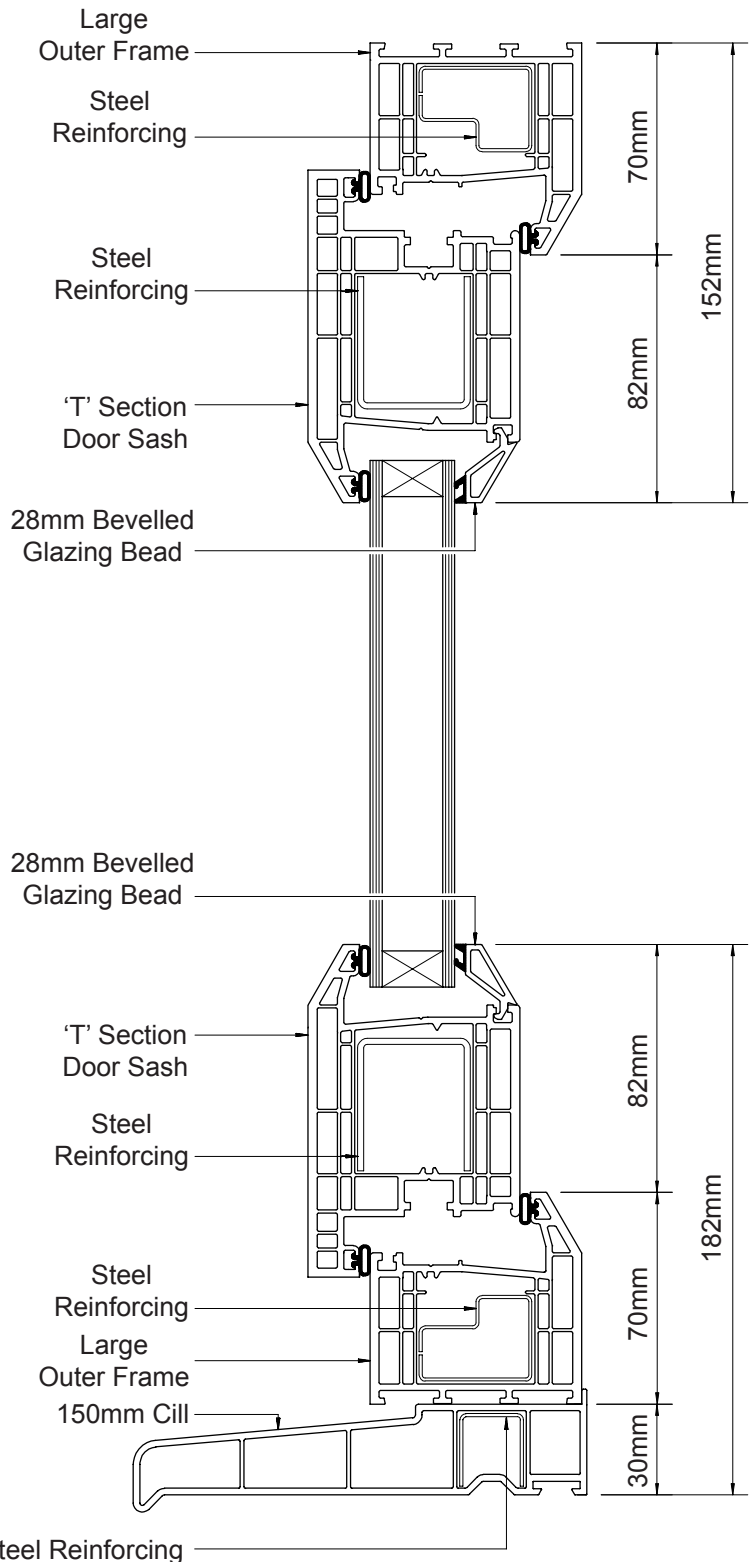

Note : All reinforcements shown are for diagramatical purposes only. For application, see pages Int.7 & Gen.5



ELITE 70 - GENERAL ASSEMBLIES

RESIDENTIAL DOOR (OVOLO)

TYPICAL OPEN-OUT RESIDENTIAL DOOR

SPECIFICATION

Large Outer Frame
'T' Section Door Sash
28mm Ovolo Glazing Bead
150mm Cill
Aluminium Reinforcing

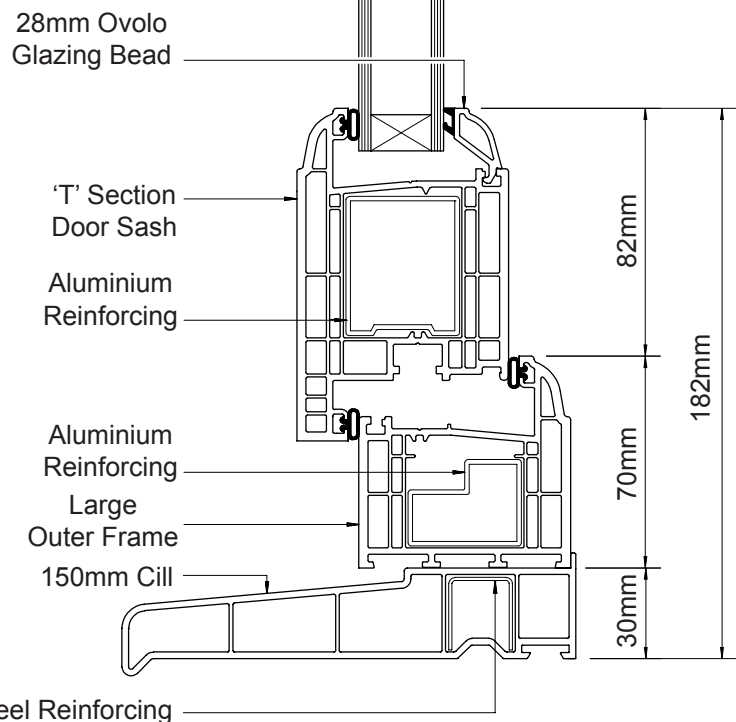
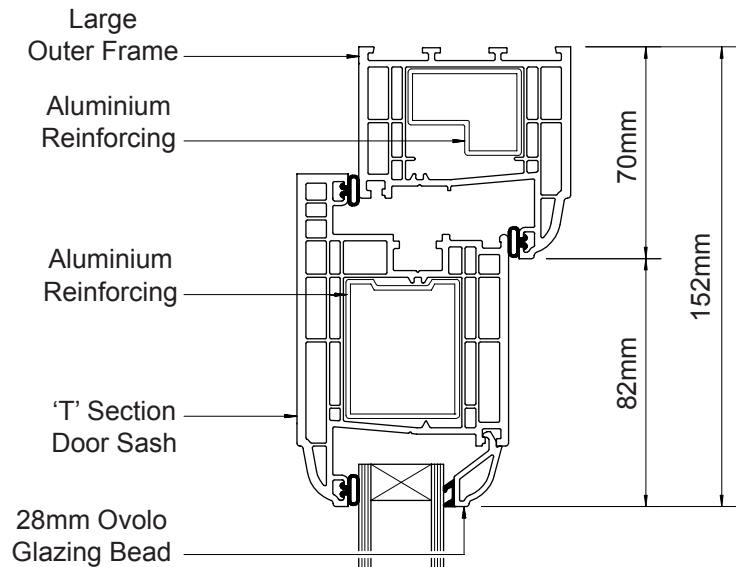
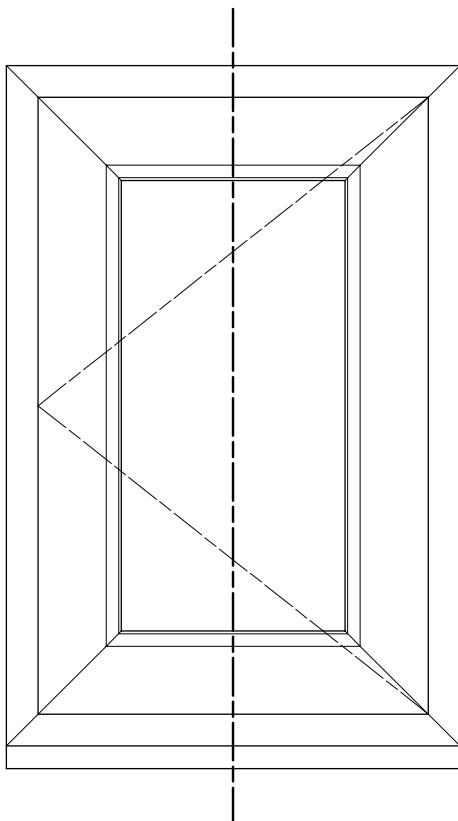

Note : All reinforcements shown are for diagramatical purposes only. For application, see pages Int.7 & Gen.5



ELITE 70 - GENERAL ASSEMBLIES

FRENCH DOORS (BEVELLED)

TYPICAL OPEN-OUT FRENCH DOORS

SPECIFICATION

Large Outer Frame
'T' Section Door Sash
Slim 'T' Meeting Rail
28mm Bevelled Glazing Bead
Steel/Aluminium Reinforcing

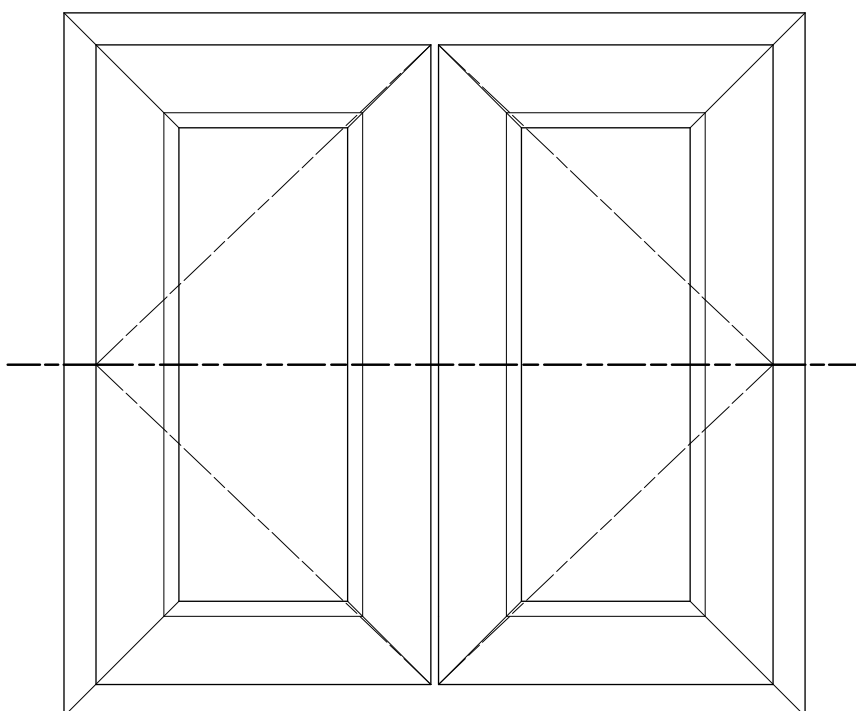
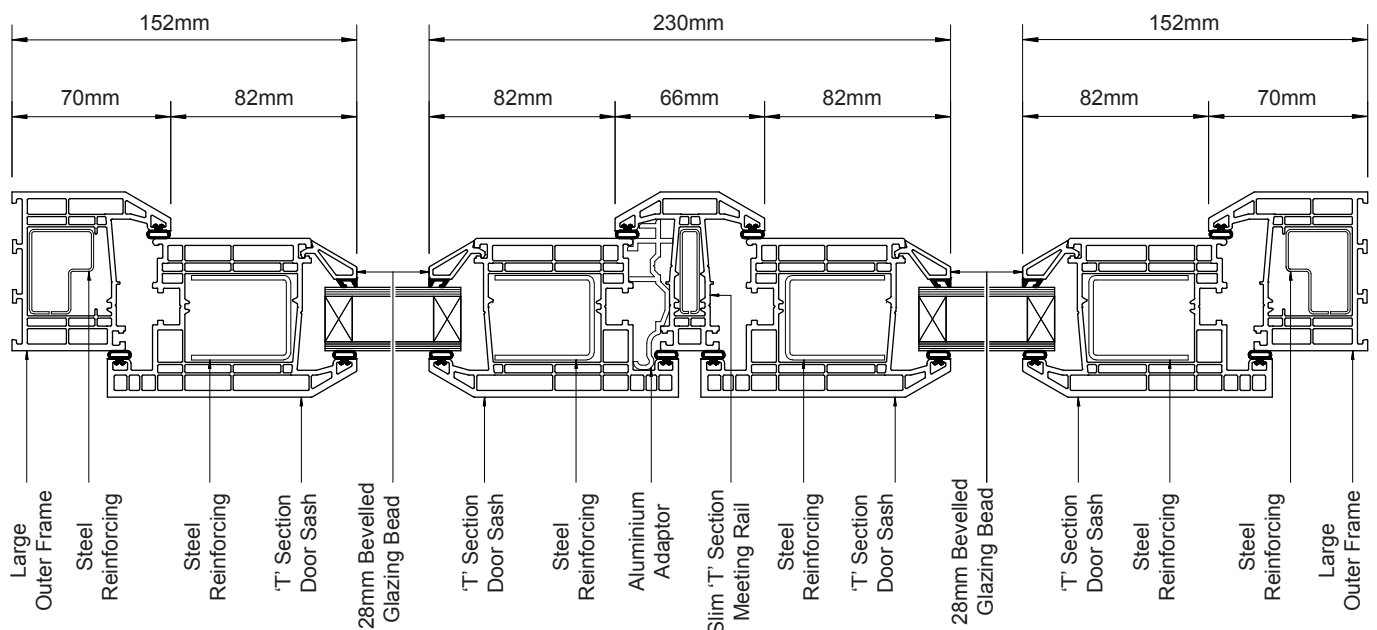

Note : All reinforcements shown are for diagramatical purposes only. For application, see pages Int.7 & Gen.5



ELITE 70 - GENERAL ASSEMBLIES

FRENCH DOORS (OVOLO)

TYPICAL OPEN-OUT FRENCH DOORS

SPECIFICATION

Large Outer Frame
'T' Section Door Sash
Slim 'T' Meeting Rail
28mm Ovolo Glazing Bead
Steel/Aluminium Reinforcing

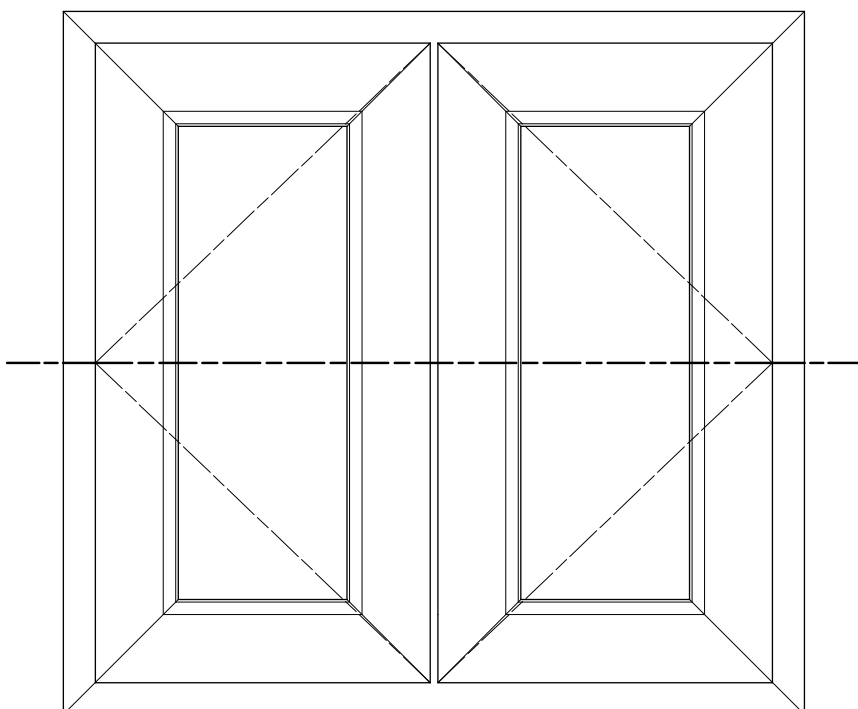
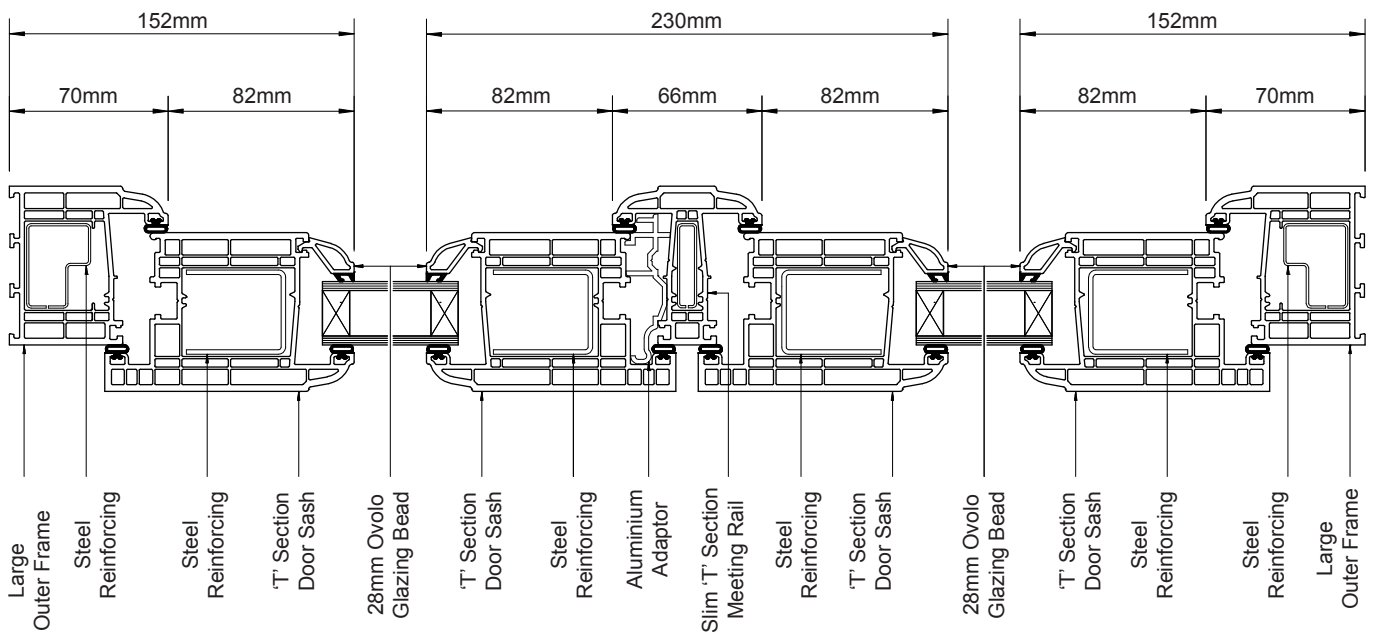

Note : All reinforcements shown are for diagramatical purposes only. For application, see pages Int.7 & Gen.5



ELITE 70 - GENERAL ASSEMBLIES

BI-FOLDING DOORS (BEVELLED)

TYPICAL OPEN-IN BI-FOLDING DOORS

SPECIFICATION

- 3 Bi-Folding Doors
- Large Outer Frame
- 'Z' Section Door Sash
- 'T' Section Door Sash
- Slim 'T' Meeting Rail
- 28mm Bevelled Glazing Bead
- Steel/Aluminium Reinforcing

NOTE :- Bi-Folding Doors are available in 3, 4, 5, 6 & 7 door options in various configurations

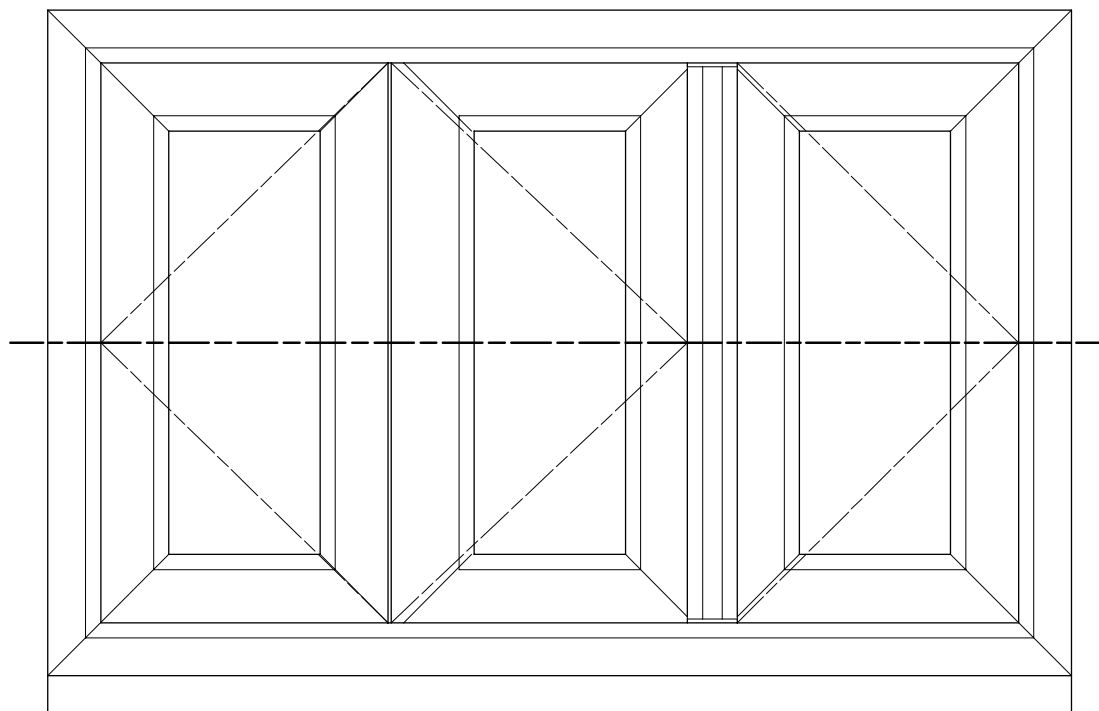
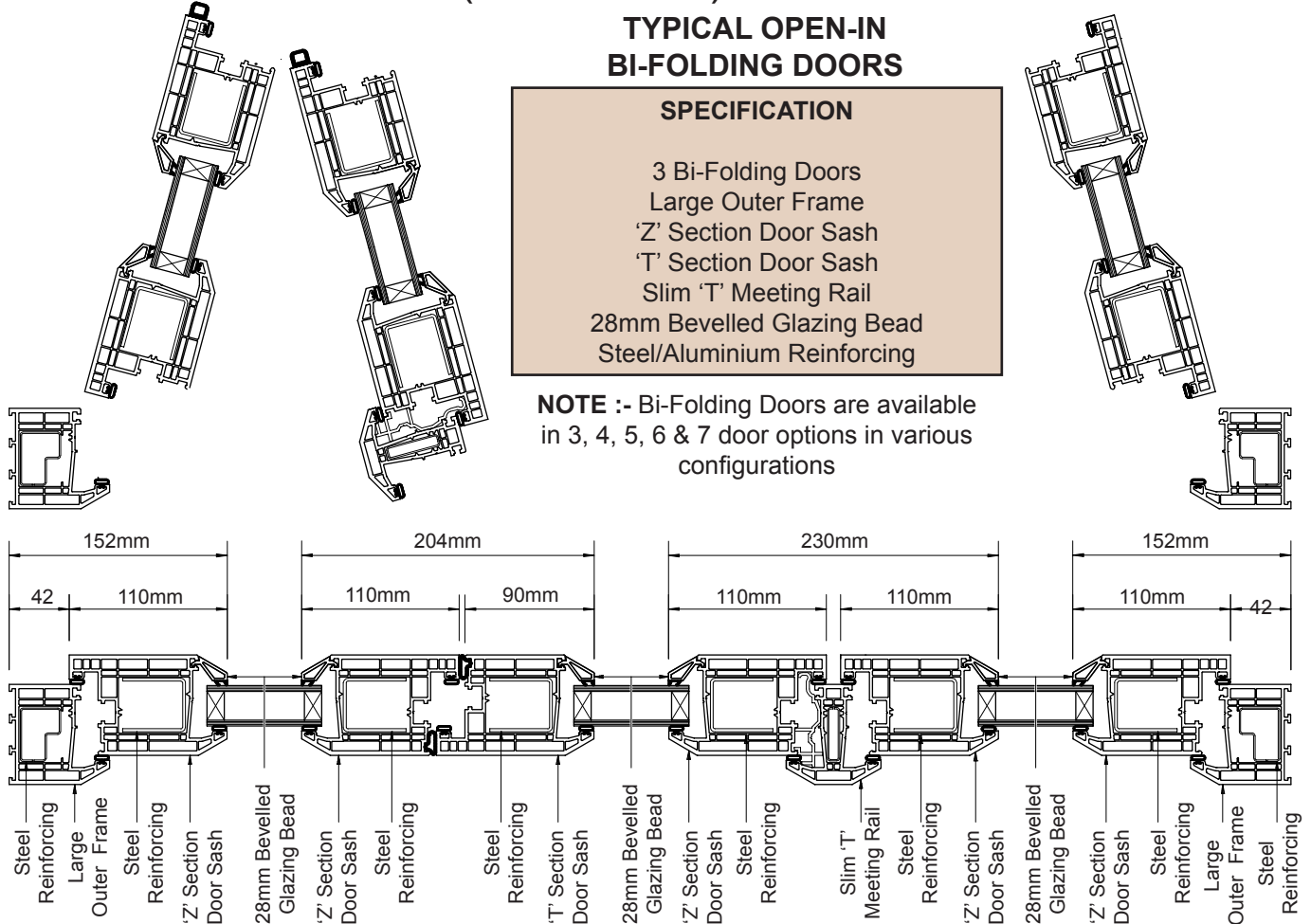

Note : All reinforcements shown are for diagramatical purposes only. For application, see pages Int.7 & Gen.5



ELITE 70 - GENERAL ASSEMBLIES

BI-FOLDING DOORS (OVOLO)

TYPICAL OPEN-IN BI-FOLDING DOORS

SPECIFICATION

- 3 Bi-Folding Doors
- Large Outer Frame
- 'Z' Section Door Sash
- 'T' Section Door Sash
- Slim 'T' Meeting Rail
- 28mm Ovolo Glazing Bead
- Steel/Aluminium Reinforcing

NOTE :- Bi-Folding Doors are available in 3, 4, 5, 6 & 7 door options in various configurations

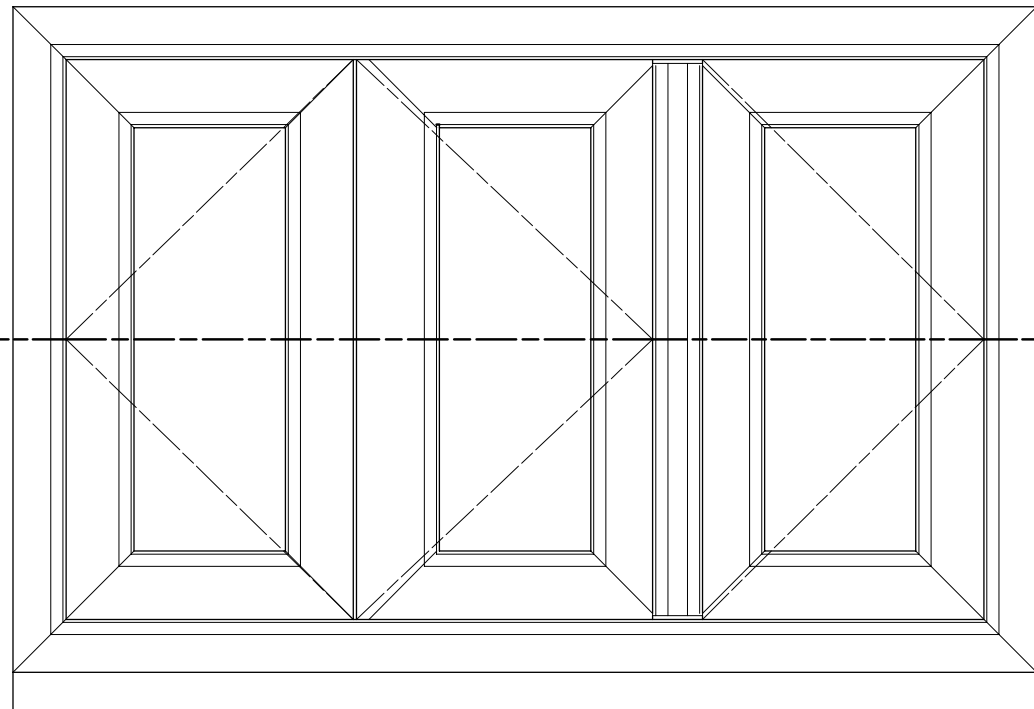
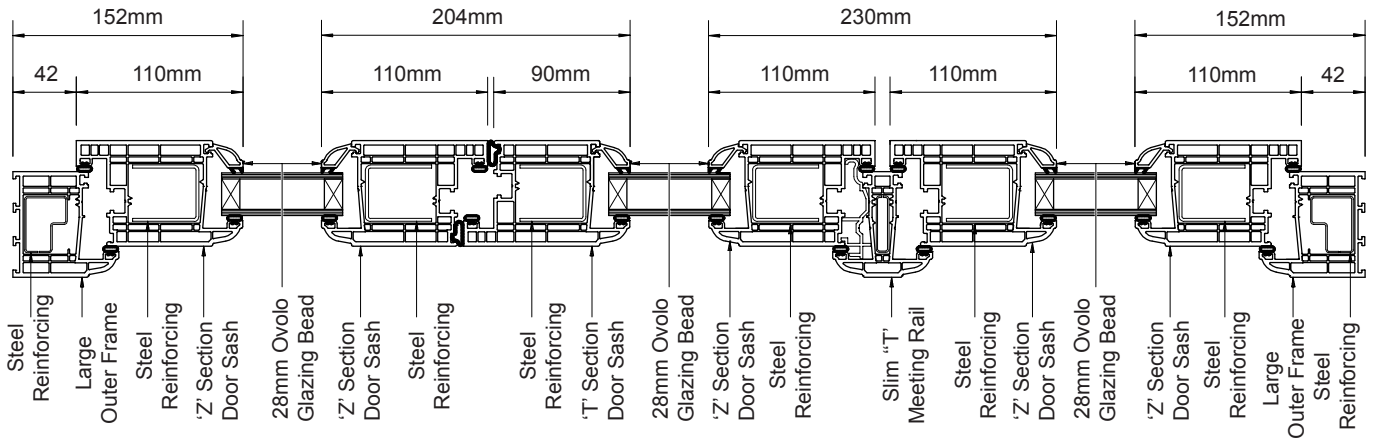
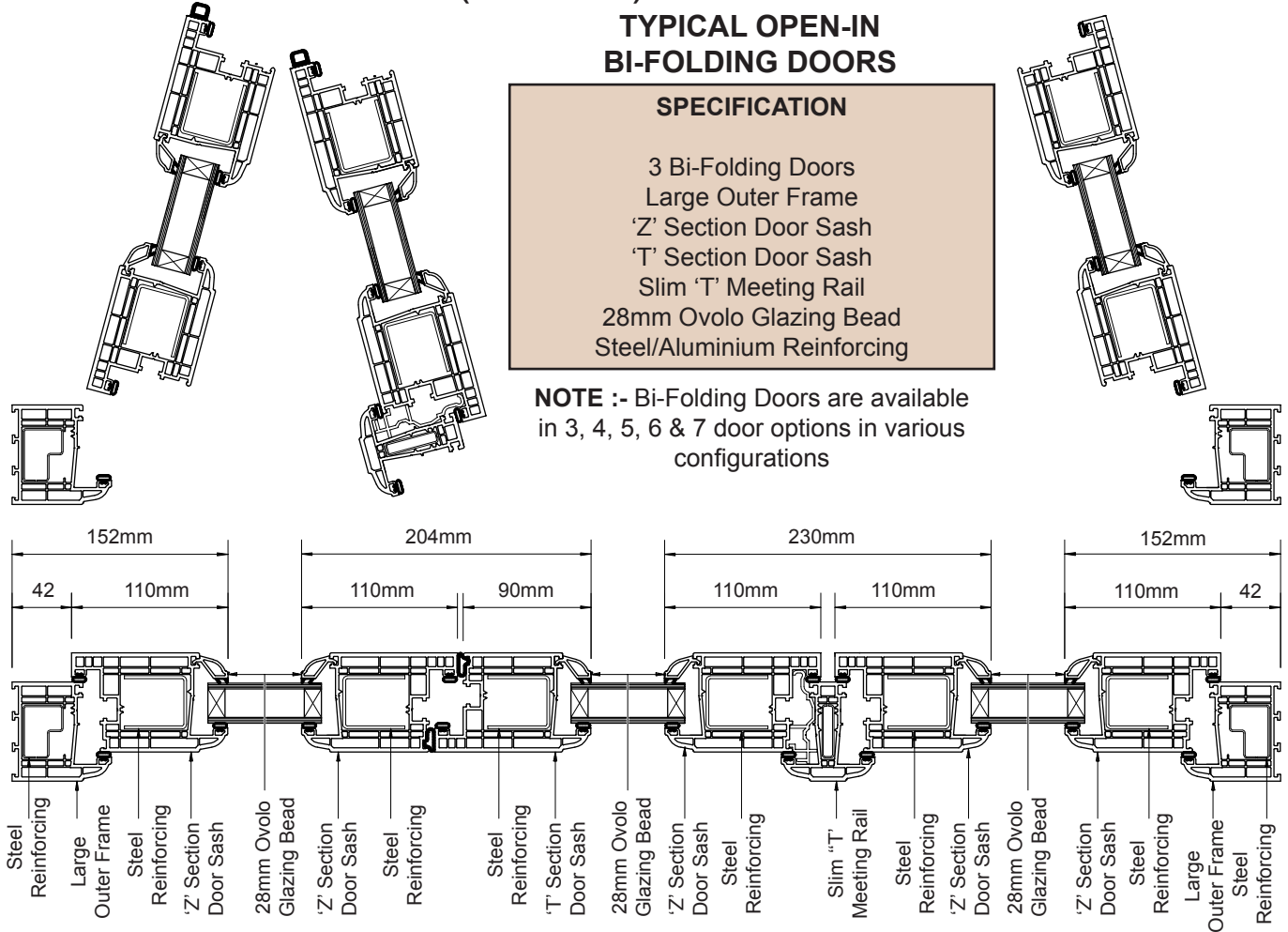

Note : All reinforcements shown are for diagramatical purposes only. For application, see pages Int.7 & Gen.5



REVERSIBLE 70 - PROFILE GUIDE

OUTER FRAMES

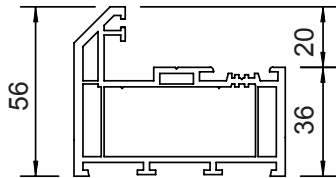

SW702
Glazed Outer Frame

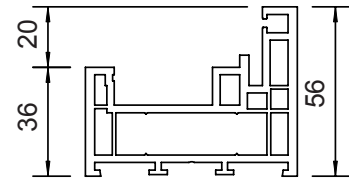

SW781
Reversible Outer Frame

TRANSOMS/MULLIONS

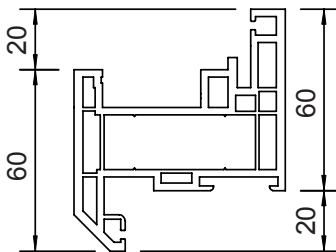

SW782
Reversible/Glazed 'Z' Section

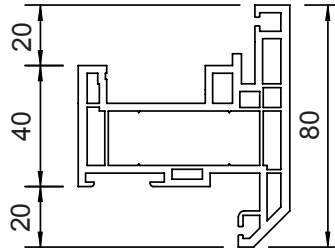

SW783
Reversible/Glazed 'T' Section

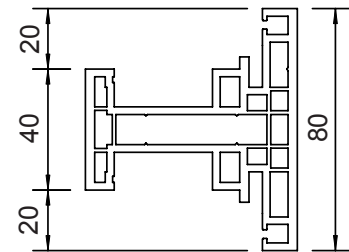

SW784
Reversible Double Mullion

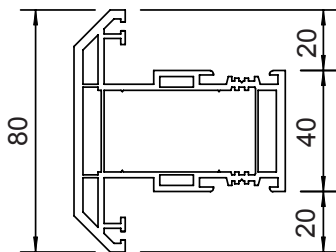

SW706
Glazed 'T' Section

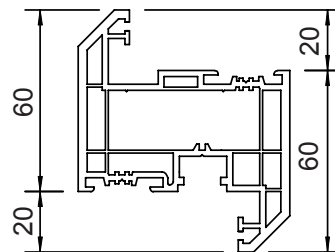

SW707
Glazed 'Z' Section

SASHES

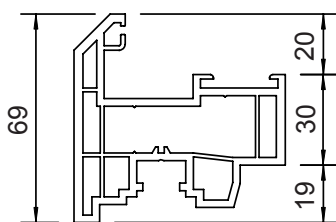

SW780
Reversible Sash

BEADS



SW724 24mm
Glazing Bead



SW739 28mm
Glazing Bead



SW771 28mm
Glazing Bead



REVERSIBLE 70 - PROFILE GUIDE

BAY COUPLINGS

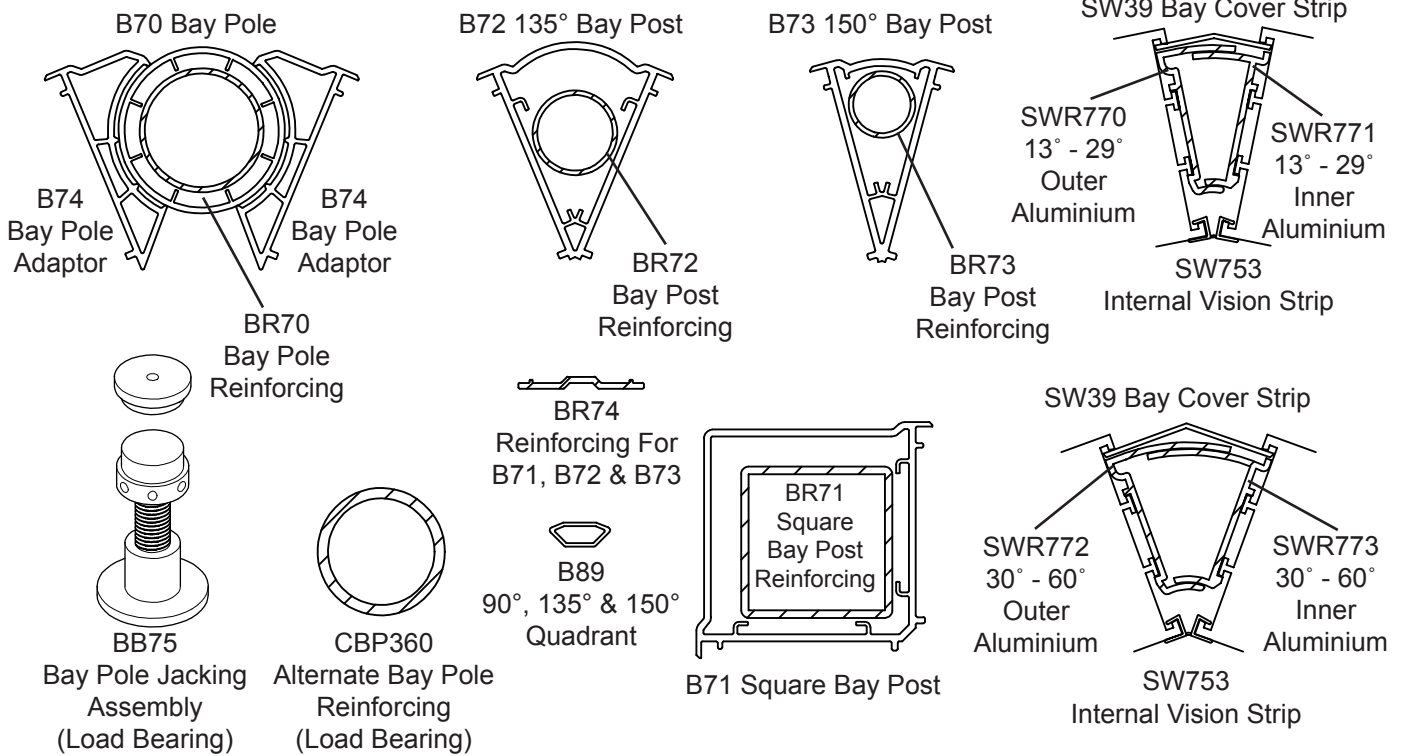

COUPLING MULLIONS

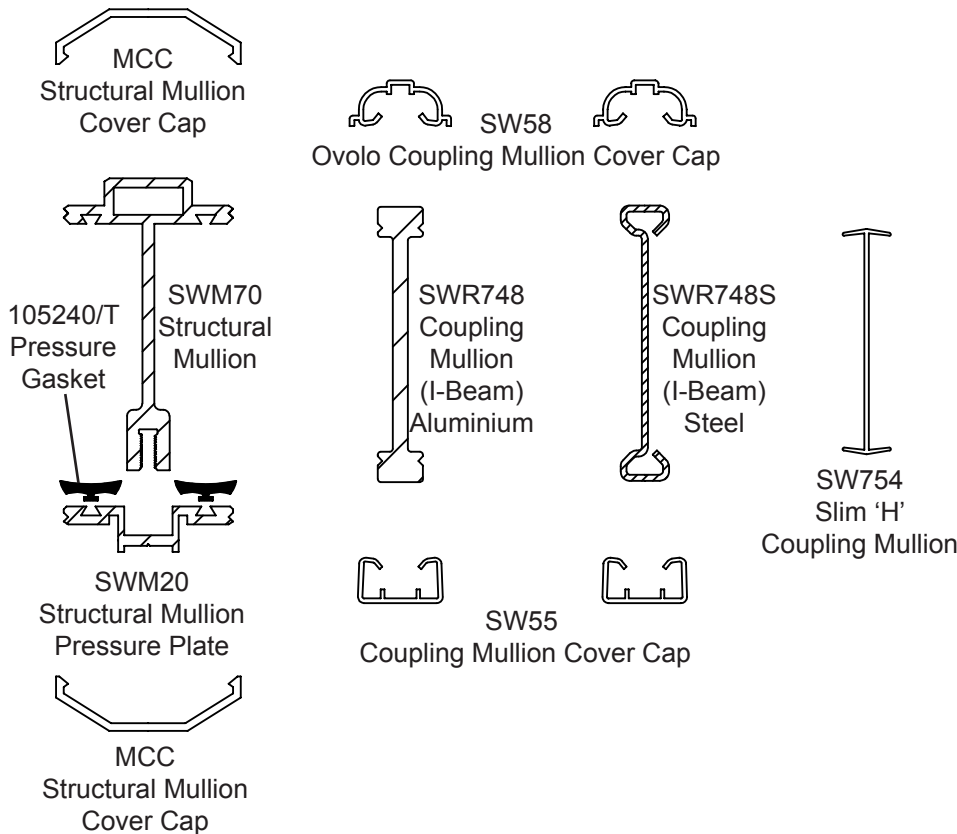

ANCILLARIES

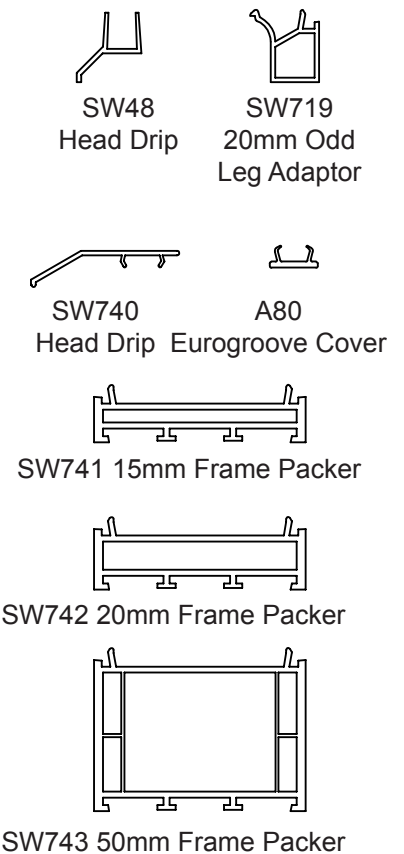

Note : Bay couplings, coupling mullions and ancillaries can be used with either Reversible 70 or Elite 70 systems



REVERSIBLE 70 - GENERAL ASSEMBLIES

REVERSIBLE WINDOW

TYPICAL OPEN-OUT REVERSIBLE WINDOW

SPECIFICATION

Intermediate Outer Frame
Reversible 'Z' Transom
Reversible Sash
Co-extruded 28mm Glazing Bead
150mm Cill
Steel Reinforcing

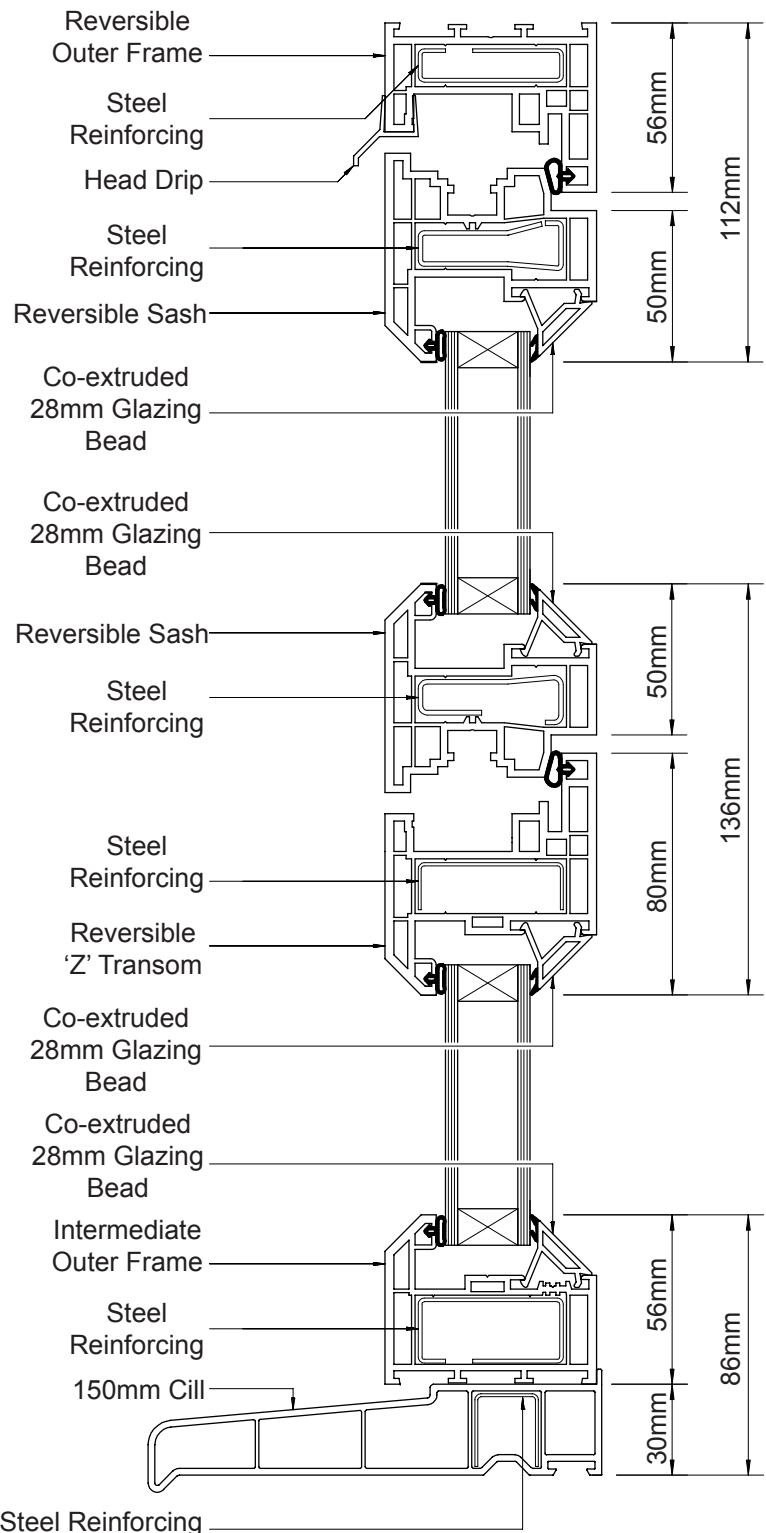
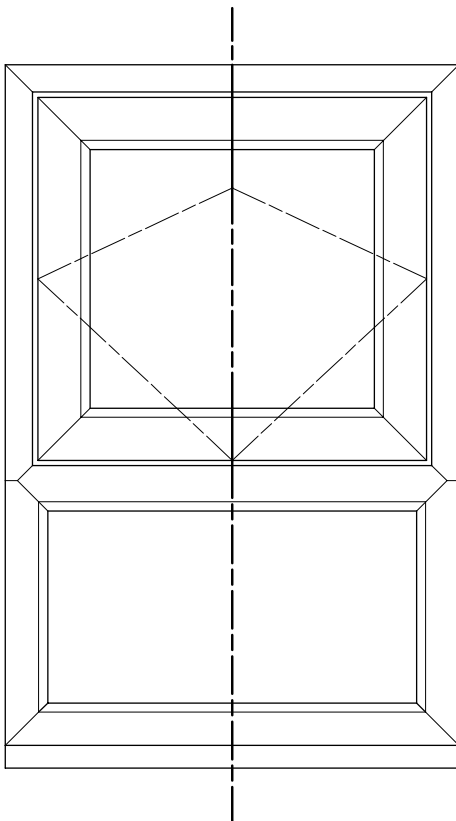

Note : All reinforcements shown are for diagramatical purposes only. For application, see pages Int.7 & Gen.6

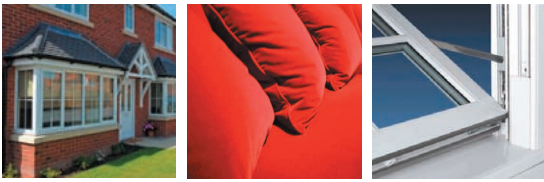

ELITE 63 - PROFILE GUIDE

OUTER FRAMES

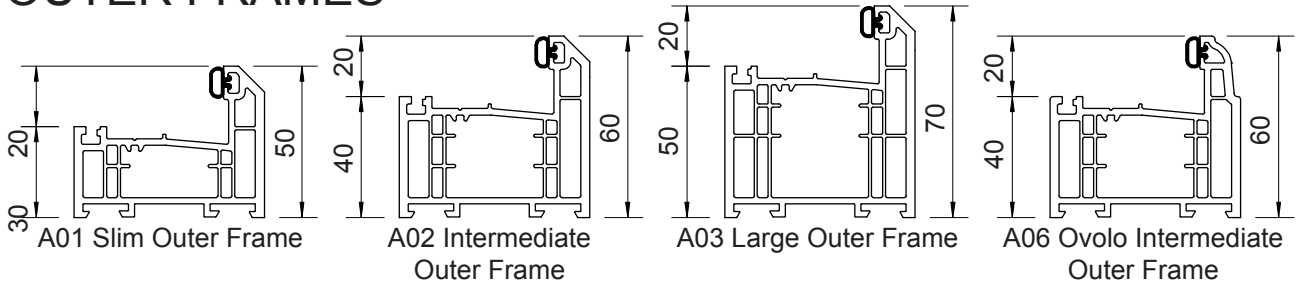

TRANSOMS/MULLIONS

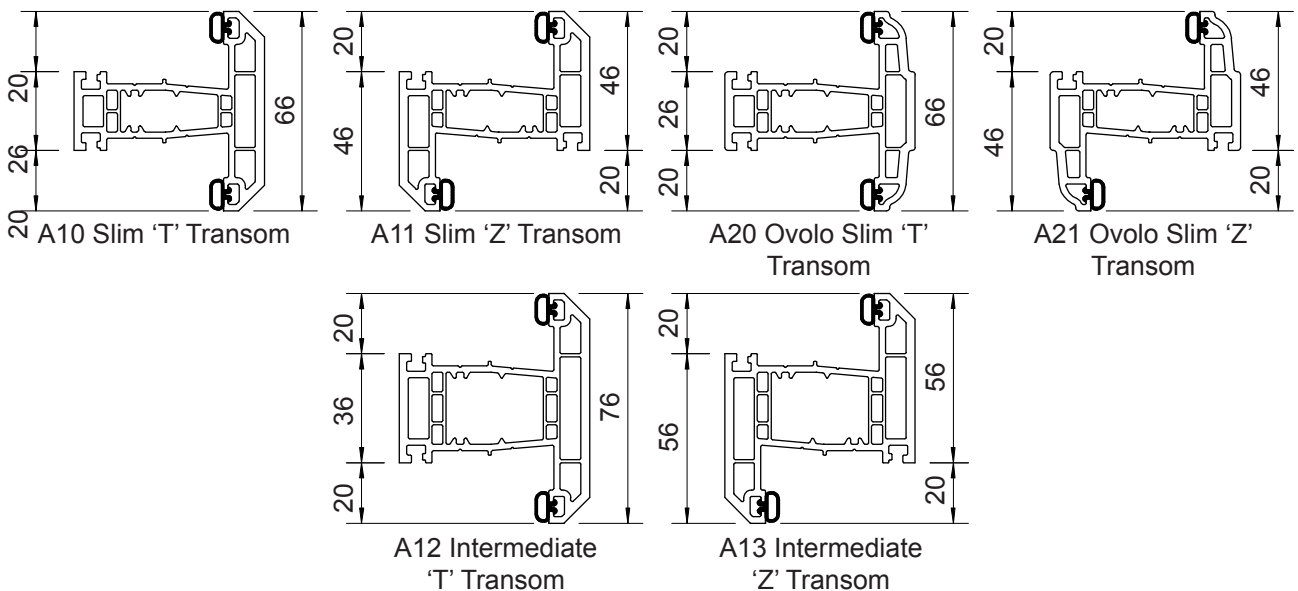

CASEMENT SASHES

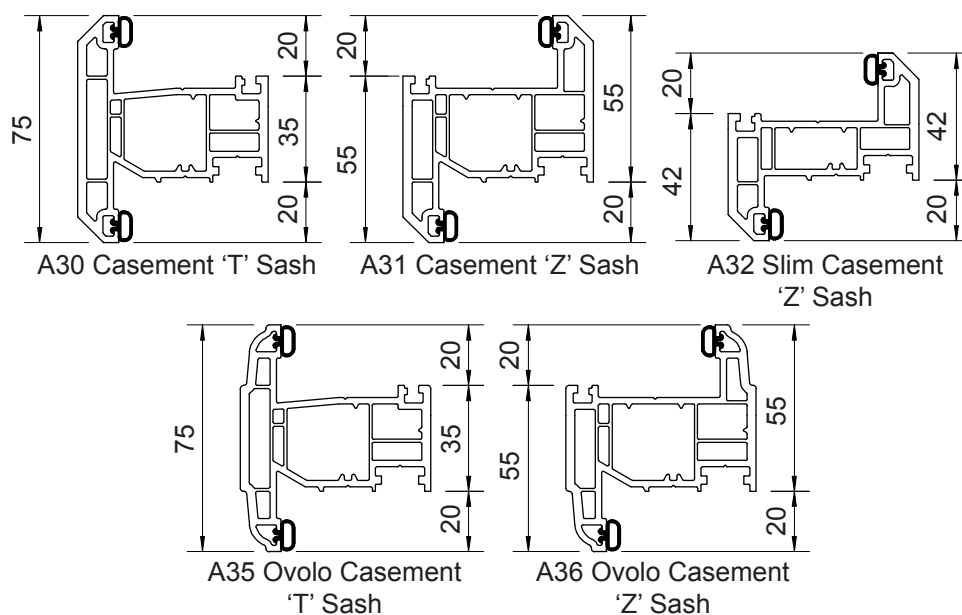



ELITE 63 - PROFILE GUIDE

MIDRAILS/MULLIONS

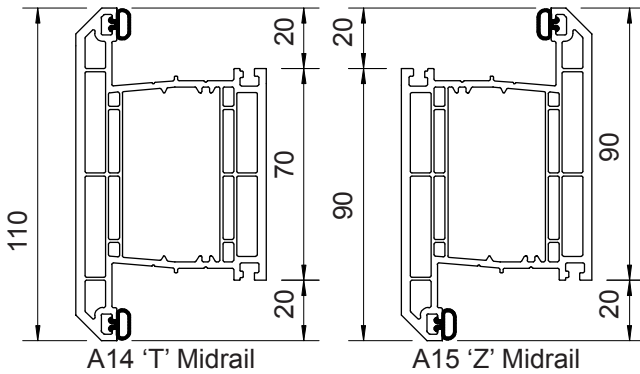

DOOR SASHES

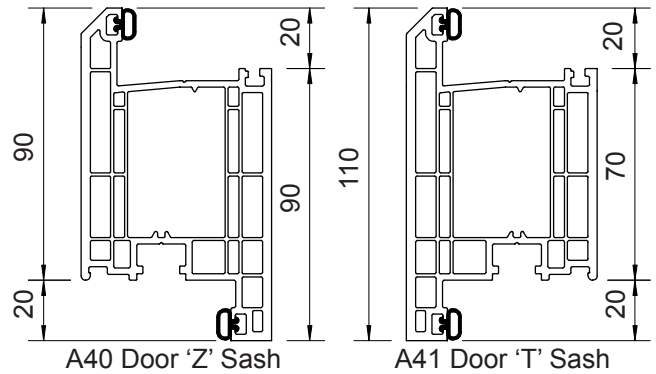

TILT & TURN

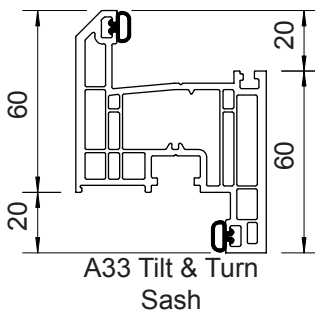

BEADS

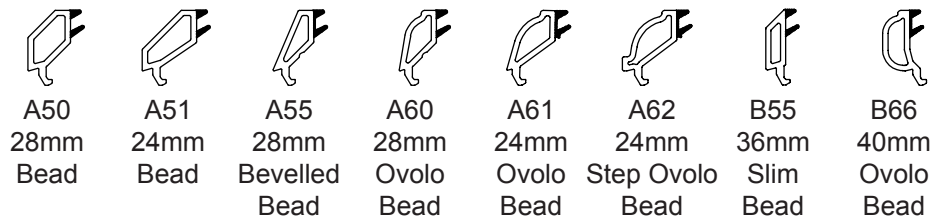

ANCILLARIES

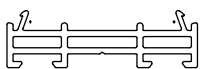

A77 15mm
Frame Packer

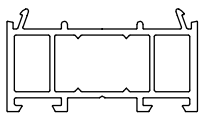

A78 30mm
Frame Packer

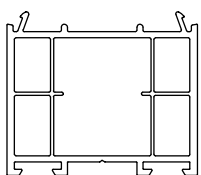

A79 50mm
Frame Packer



A75 Clip-On
Chamfered
Georgian Bar



A84 20mm
Stone Cill
Adaptor



B86
Weather Drip

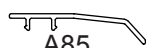

A85
Head Drip



A76 Clip-On
Ovolo
Georgian Bar



VS11 Stick-On
Ovolo
Georgian Bar



A82 50mm
Stone Cill
Adaptor



A80
Eurogroove
Cover



ELITE 63 - PROFILE GUIDE

BAY COUPLINGS

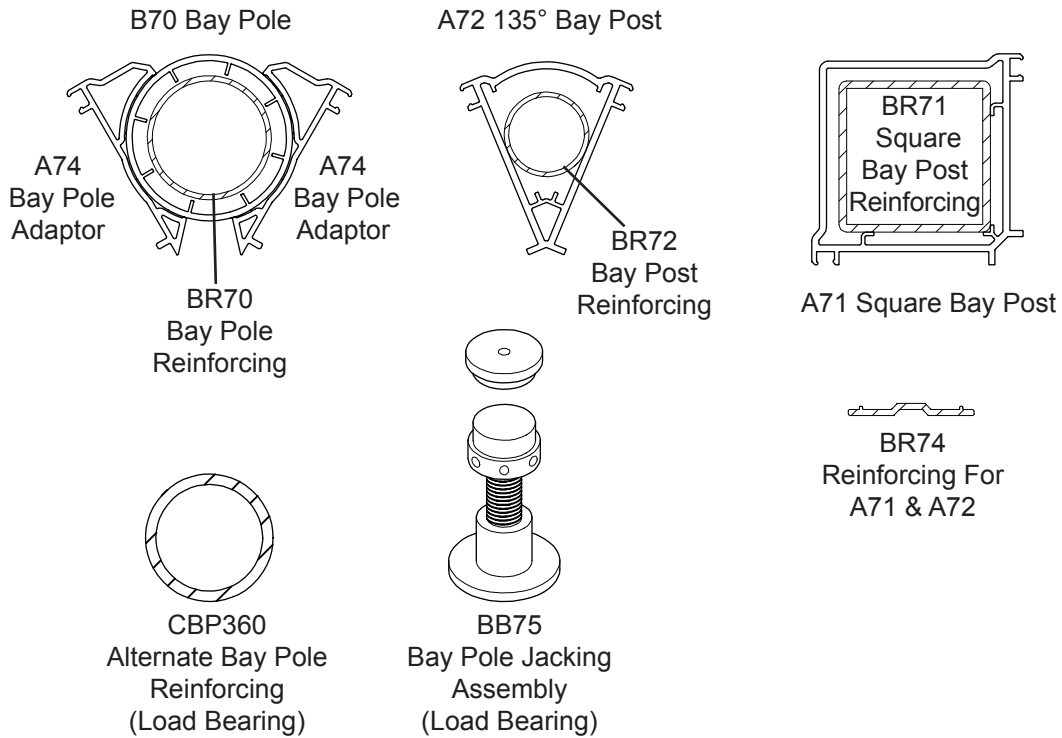

COUPLING MULLIONS

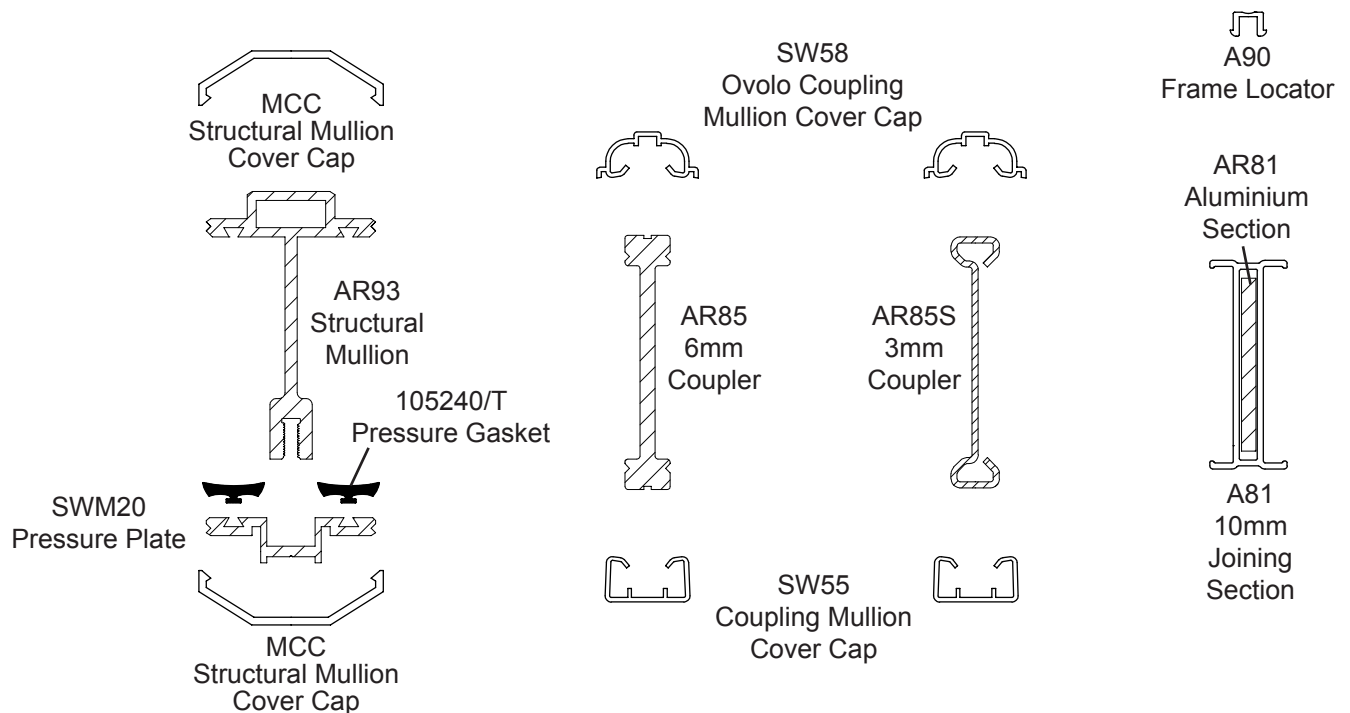



ELITE 63 - GENERAL ASSEMBLIES

INTERNALLY BEADED CASEMENT (CHAMFERED)

TYPICAL OPEN-OUT CASEMENT WINDOW

SPECIFICATION

Intermediate Outer Frame
Slim 'Z' Transom
'T' Section Sash
28mm Glazing Bead
150mm Cill
Steel Reinforcing

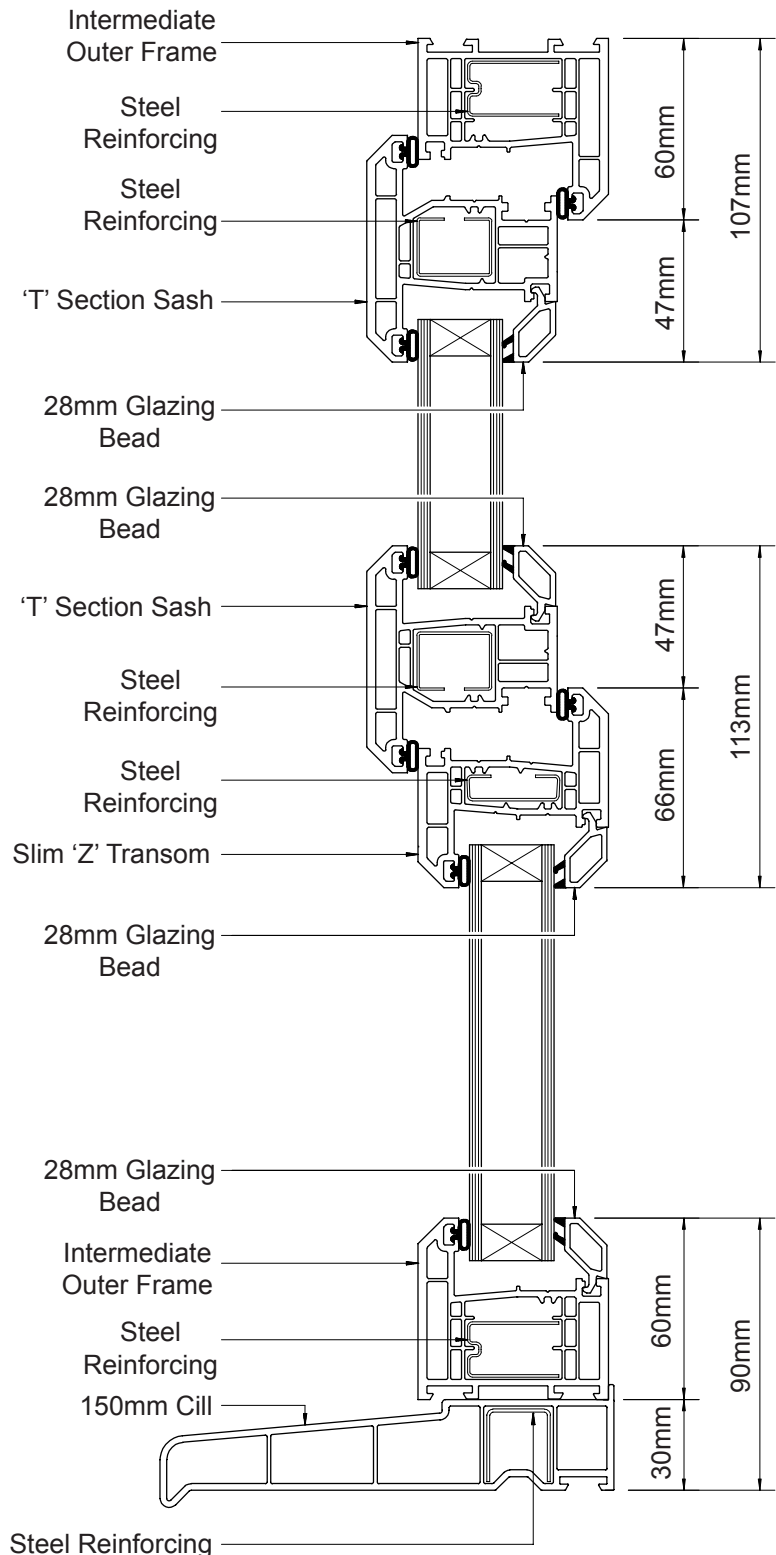
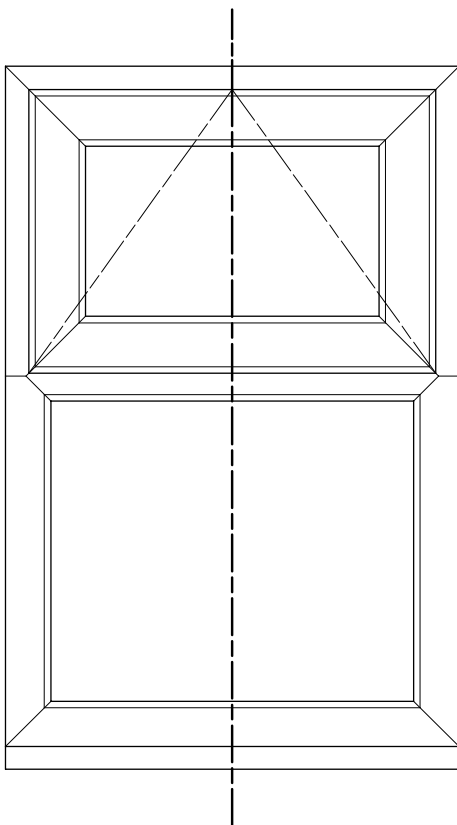

Note : All reinforcements shown are for diagrammatical purposes only. For application, see pages Int.7 - Gen.7



ELITE 63 - GENERAL ASSEMBLIES

INTERNALLY BEADED CASEMENT (OVOLO)

TYPICAL OPEN-OUT CASEMENT WINDOW

SPECIFICATION

Intermediate Outer Frame
Slim 'Z' Transom
'T' Section Sash
28mm Ovolo Glazing Bead
150mm Cill
Steel Reinforcing

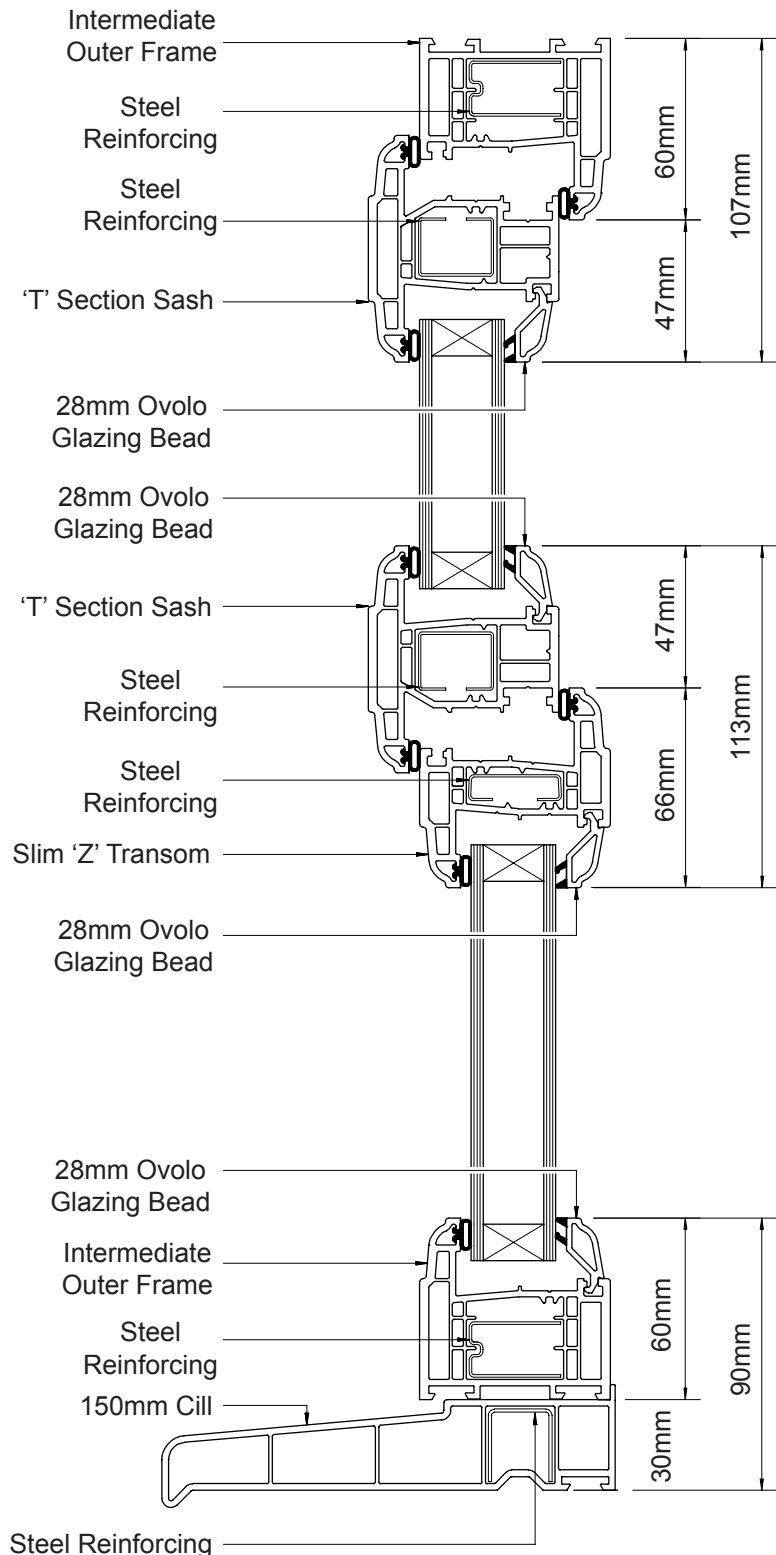
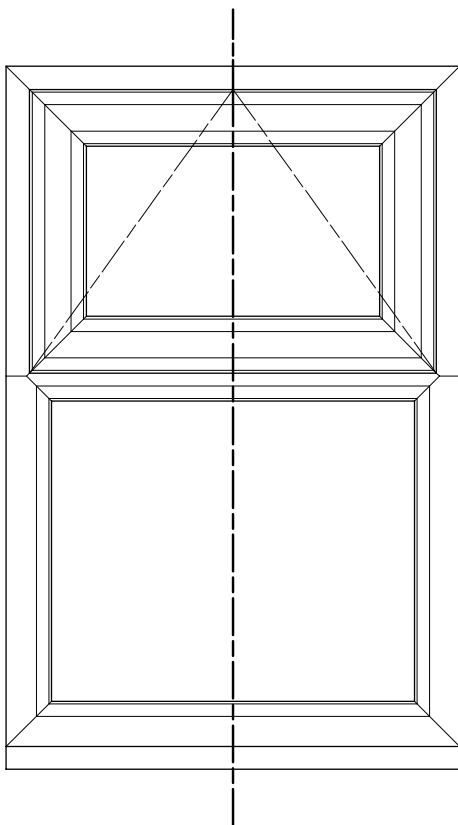

Note : All reinforcements shown are for diagrammatical purposes only. For application, see pages Int.7 - Gen.7



ELITE 63 - GENERAL ASSEMBLIES

EXTERNALLY BEADED CASEMENT (CHAMFERED)

TYPICAL OPEN-OUT CASEMENT WINDOW

SPECIFICATION

- Slim Outer Frame
- Slim 'T' Transom
- 'Z' Section Sash
- 24mm Glazing Bead
- 180mm Cill
- Steel Reinforcing

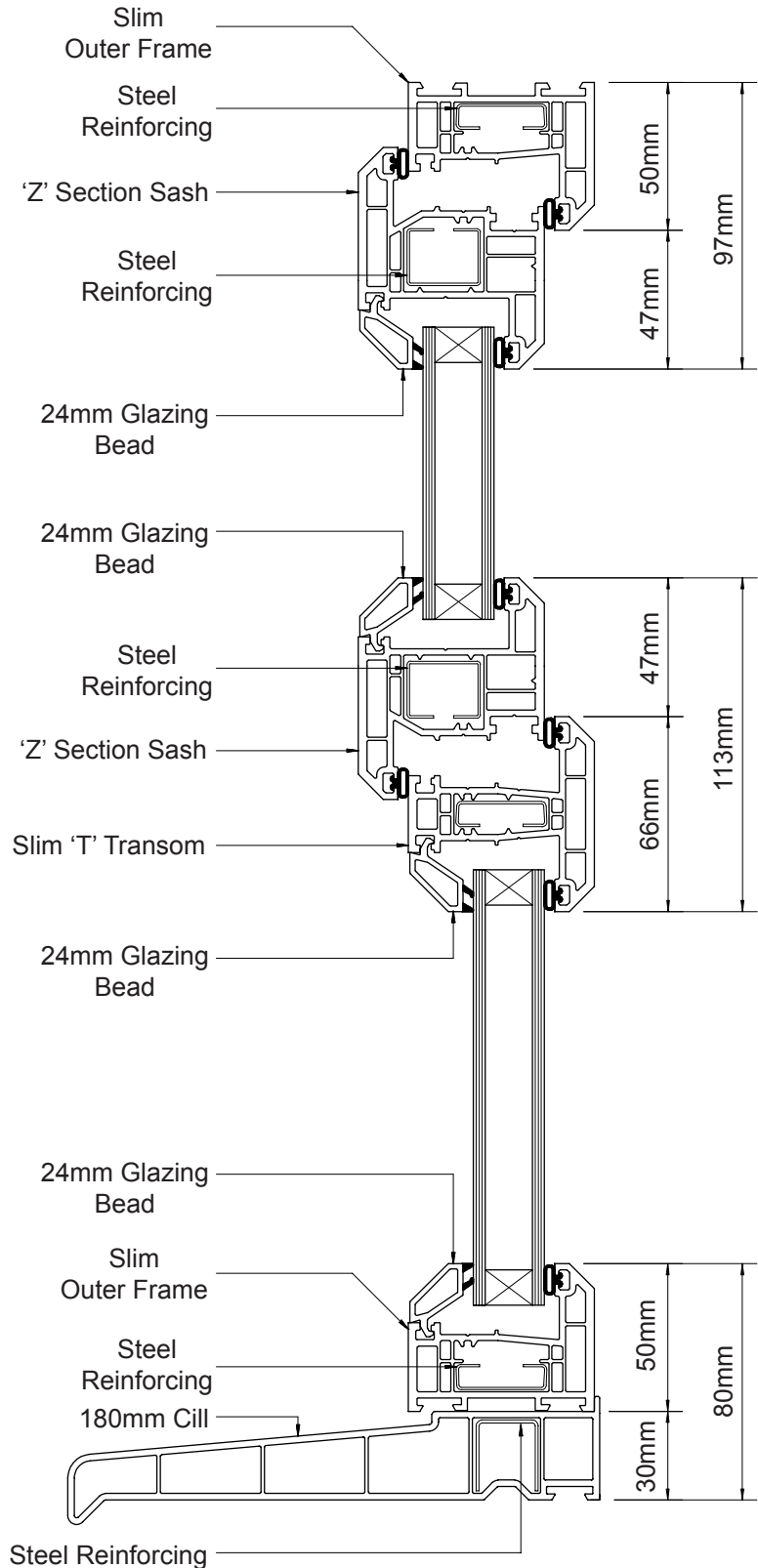
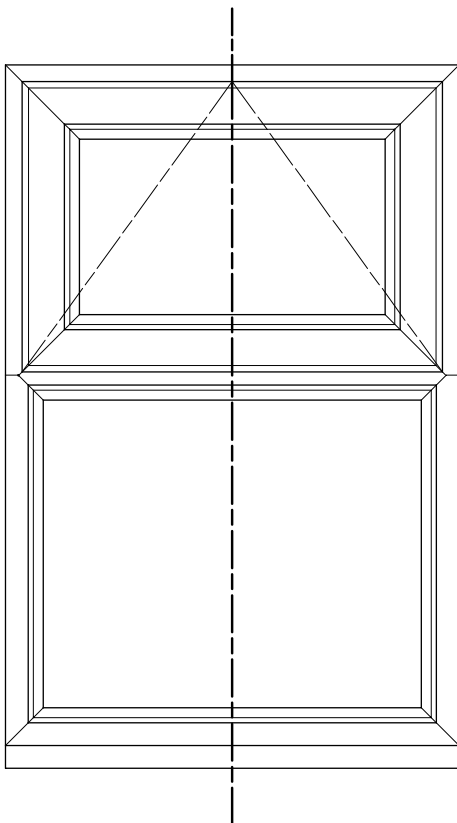

Note : All reinforcements shown are for diagramatical purposes only. For application, see pages Int.7 - Gen.7



ELITE 63 - GENERAL ASSEMBLIES

EXTERNALLY BEADED CASEMENT (OVOLO)

TYPICAL OPEN-OUT CASEMENT WINDOW

SPECIFICATION

Intermediate Outer Frame
Slim 'T' Transom
'Z' Section Sash
28mm Ovolo Glazing Bead
150mm Cill
Steel Reinforcing

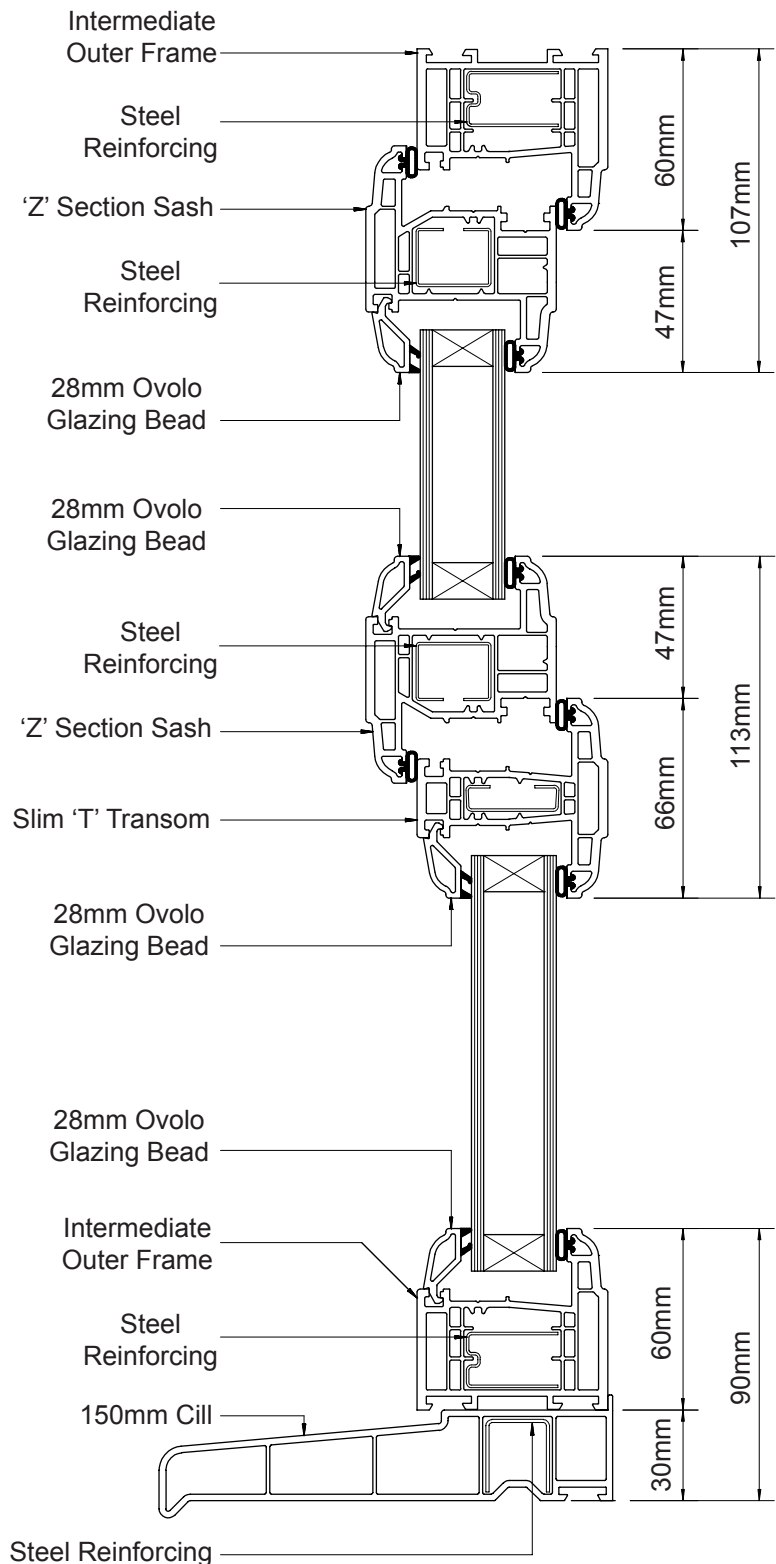
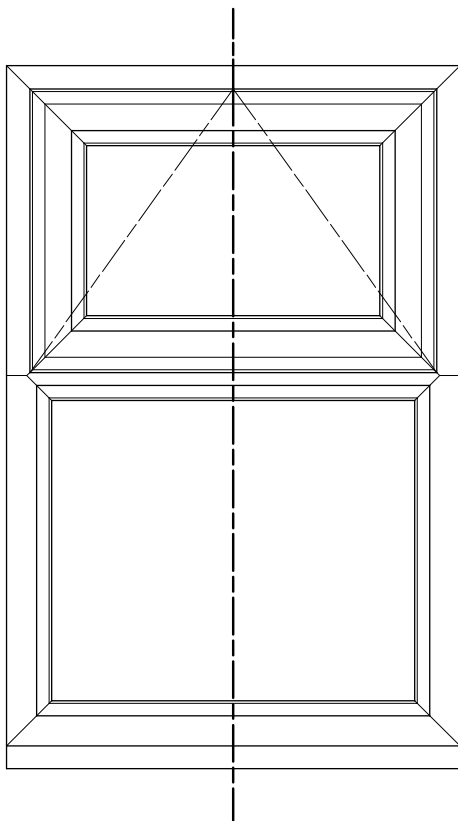

Note : All reinforcements shown are for diagrammatical purposes only. For application, see pages Int.7- Gen.7



ELITE 63 - GENERAL ASSEMBLIES

EXTERNALLY BEADED CASEMENT (SLIM SASH)

TYPICAL OPEN-OUT CASEMENT WINDOW

SPECIFICATION

- Slim Outer Frame
- Slim 'T' Transom
- Slim 'Z' Section Sash
- 24mm Glazing Bead
- 180mm Cill
- Steel Reinforcing

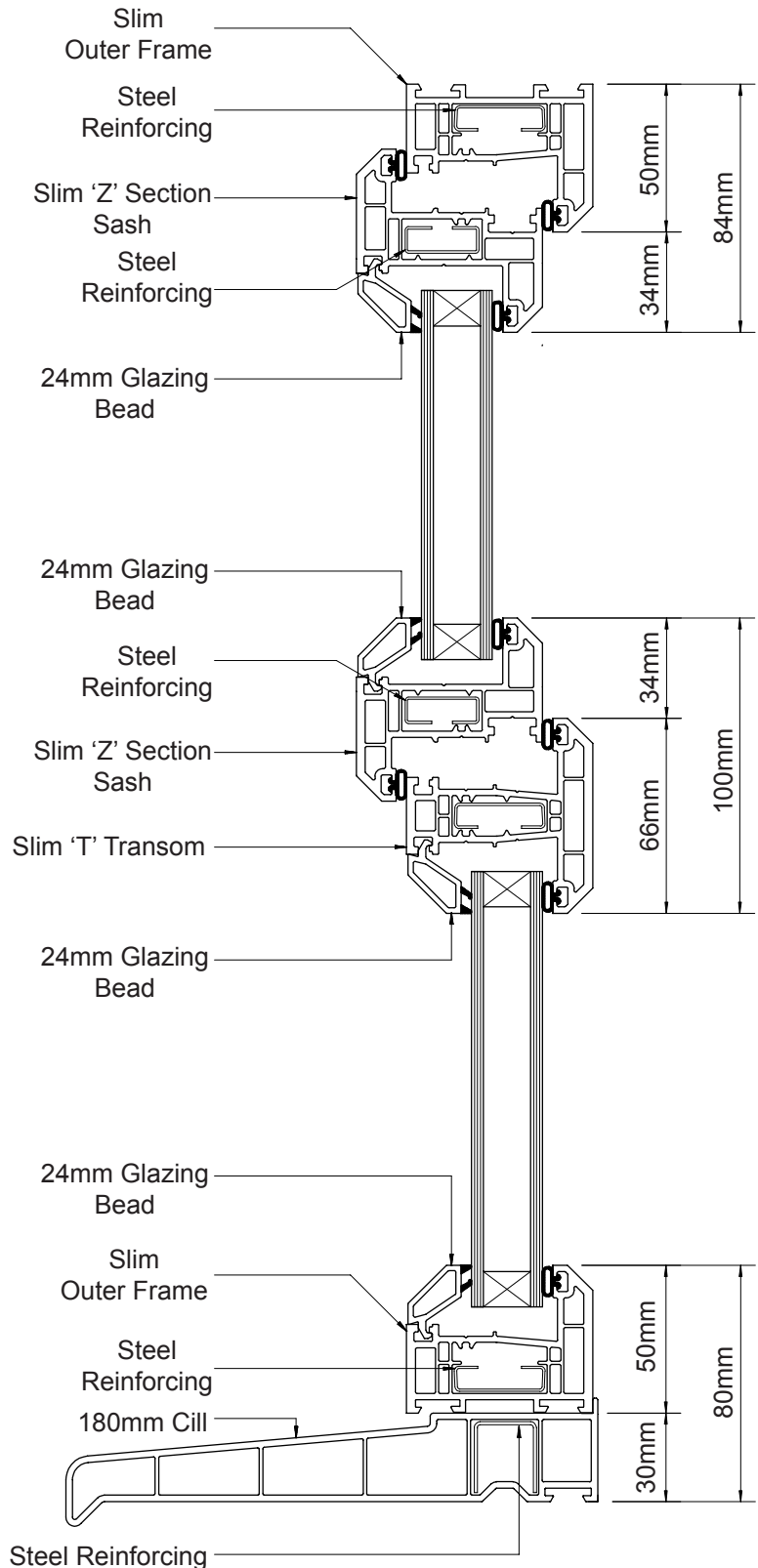
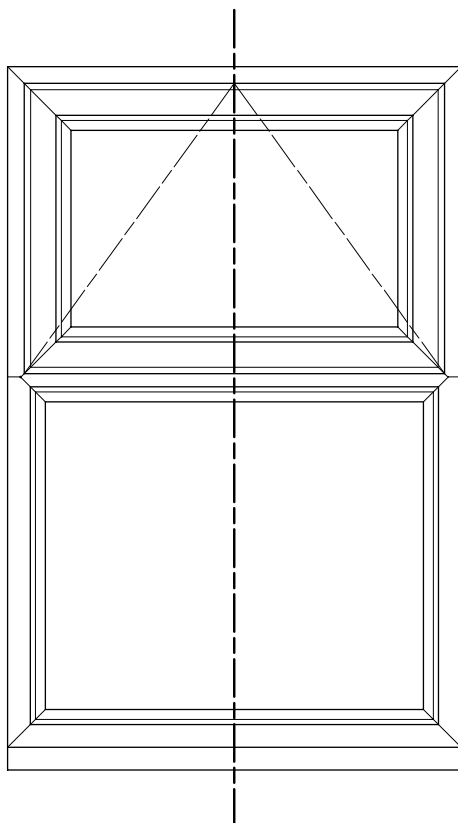

Note : All reinforcements shown are for diagramatical purposes only. For application, see pages Int.7 - Gen.7



ELITE 63 - GENERAL ASSEMBLIES

TILT & TURN WINDOW

TYPICAL OPEN-IN TILT & TURN WINDOW

SPECIFICATION

Large Outer Frame
Intermediate 'T' Transom
'Z' Section Tilt & Turn Sash
24mm Glazing Bead
85mm Cill
Steel Reinforcing

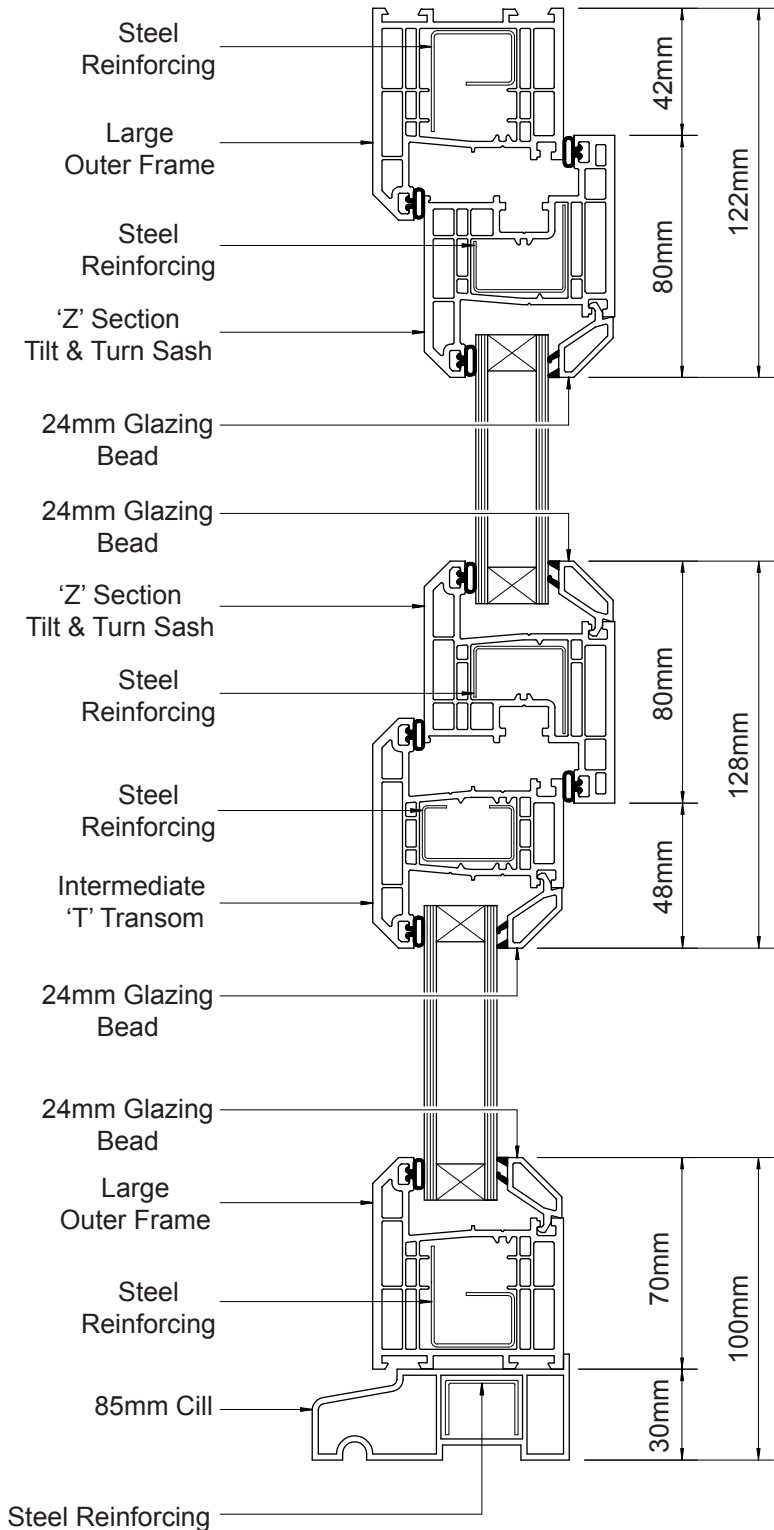
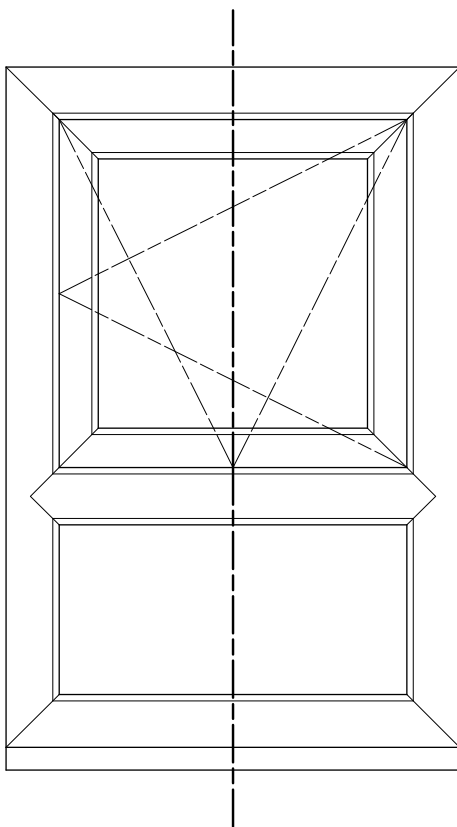

Note : All reinforcements shown are for diagrammatical purposes only. For application, see pages Int.7 - Gen.7



ELITE 63 - GENERAL ASSEMBLIES

RESIDENTIAL DOOR

TYPICAL OPEN-IN RESIDENTIAL DOOR

SPECIFICATION

Large Outer Frame
'Z' Section Door Sash
'T' Section Midrail
28mm Glazing Bead
Aluminium Low Threshold
Steel Reinforcing

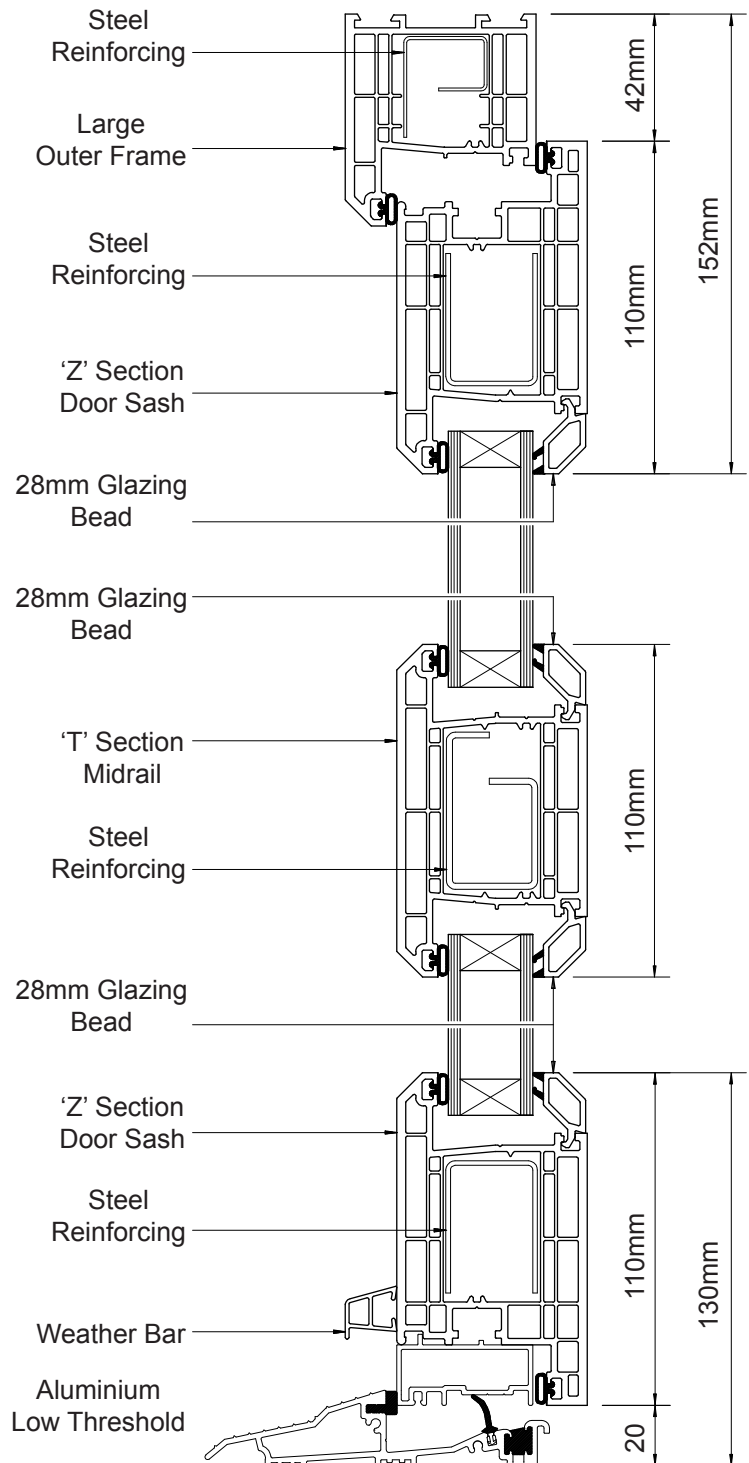
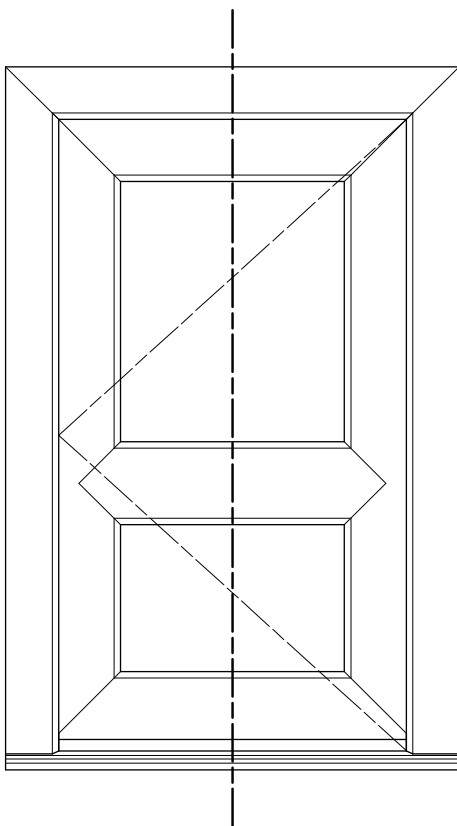

Note : All reinforcements shown are for diagramatical purposes only. For application, see pages Int.7 - Gen.7



ELITE 63 - GENERAL ASSEMBLIES

RESIDENTIAL DOOR

TYPICAL OPEN-OUT RESIDENTIAL DOOR

SPECIFICATION

Large Outer Frame
'T' Section Door Sash
24mm Glazing Bead
180mm Cill
Steel Reinforcing

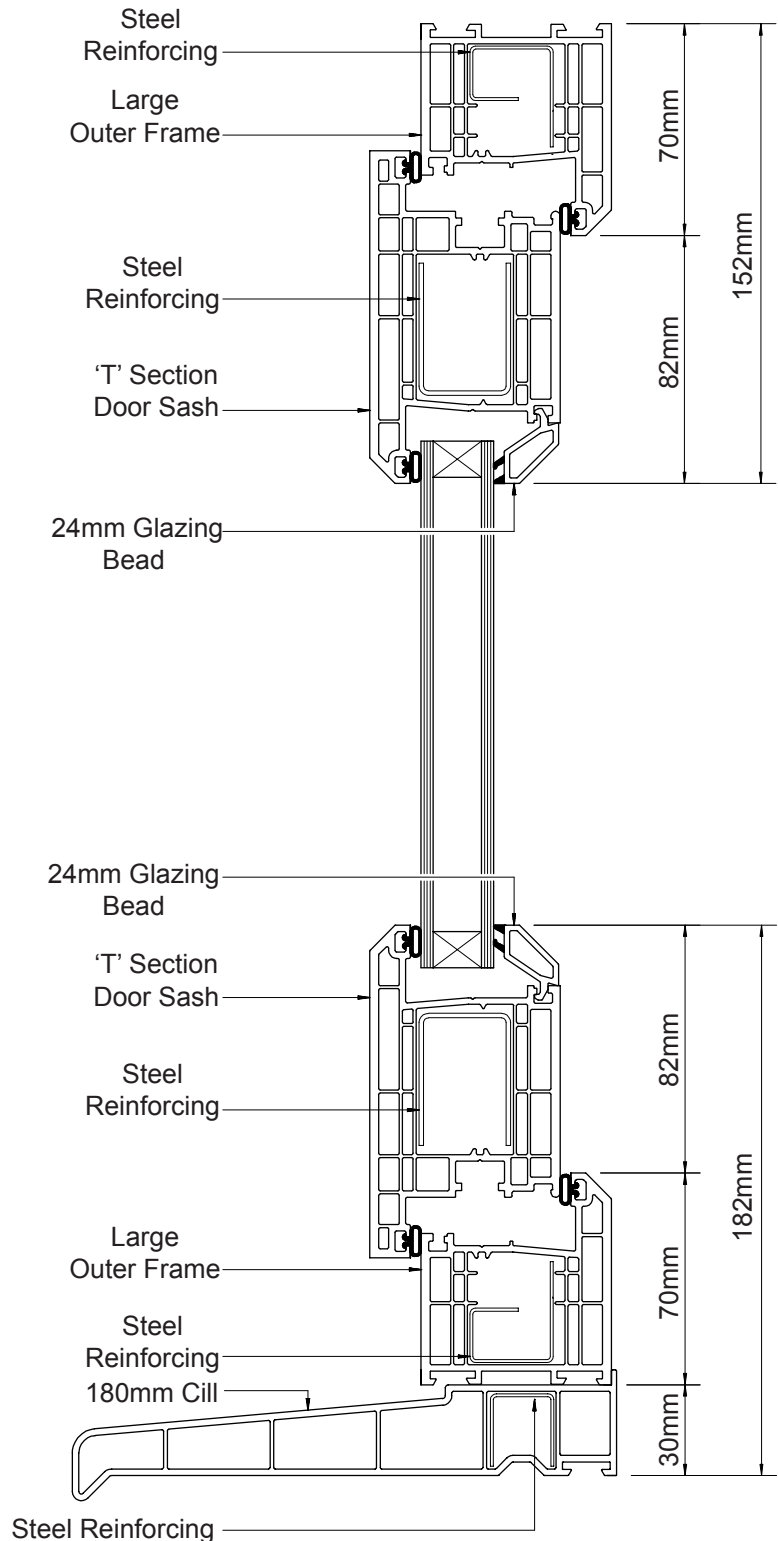
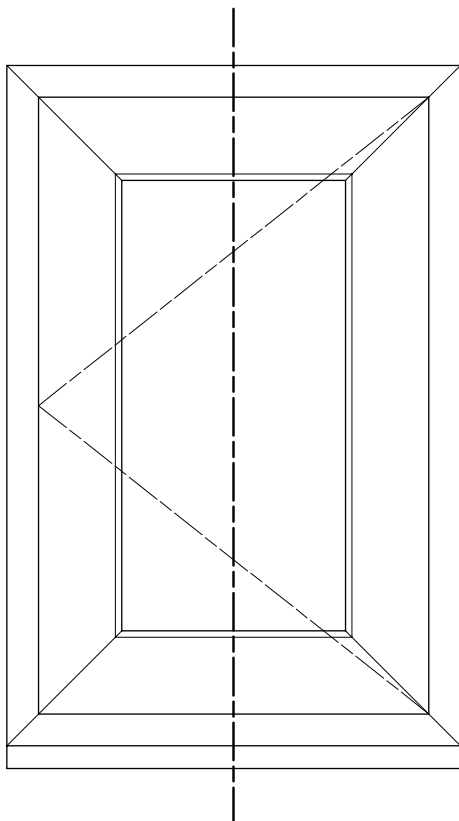

Note : All reinforcements shown are for diagramatical purposes only. For application, see pages Int.7 - Gen.7



ELITE 63 - GENERAL ASSEMBLIES

FRENCH DOORS TYPICAL OPEN-OUT FRENCH DOORS

SPECIFICATION

Large Outer Frame
'T' Section Door Sash
Slim 'T' Meeting Rail
28mm Glazing Bead
Steel/Aluminium Reinforcing

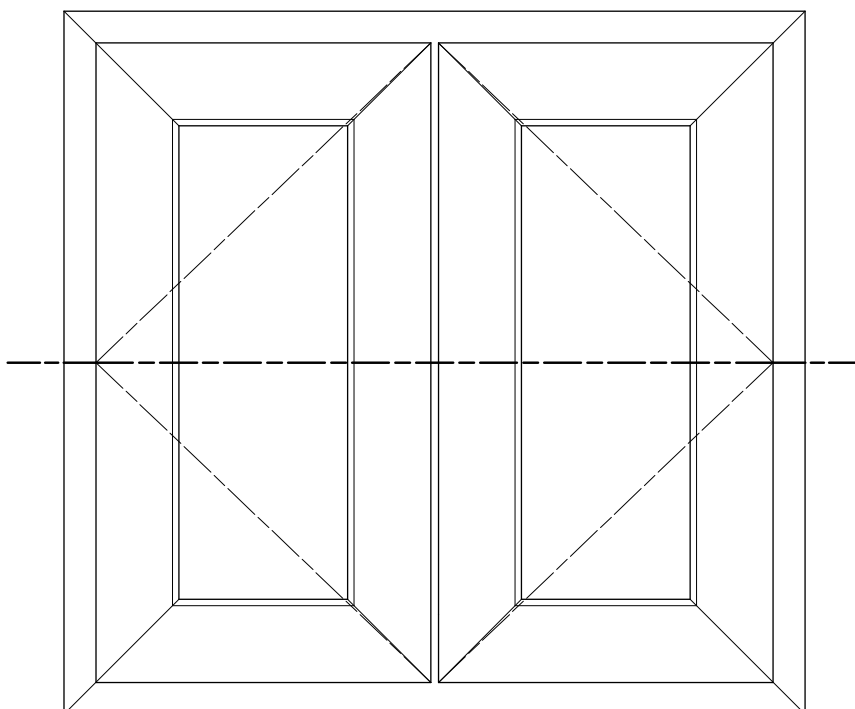
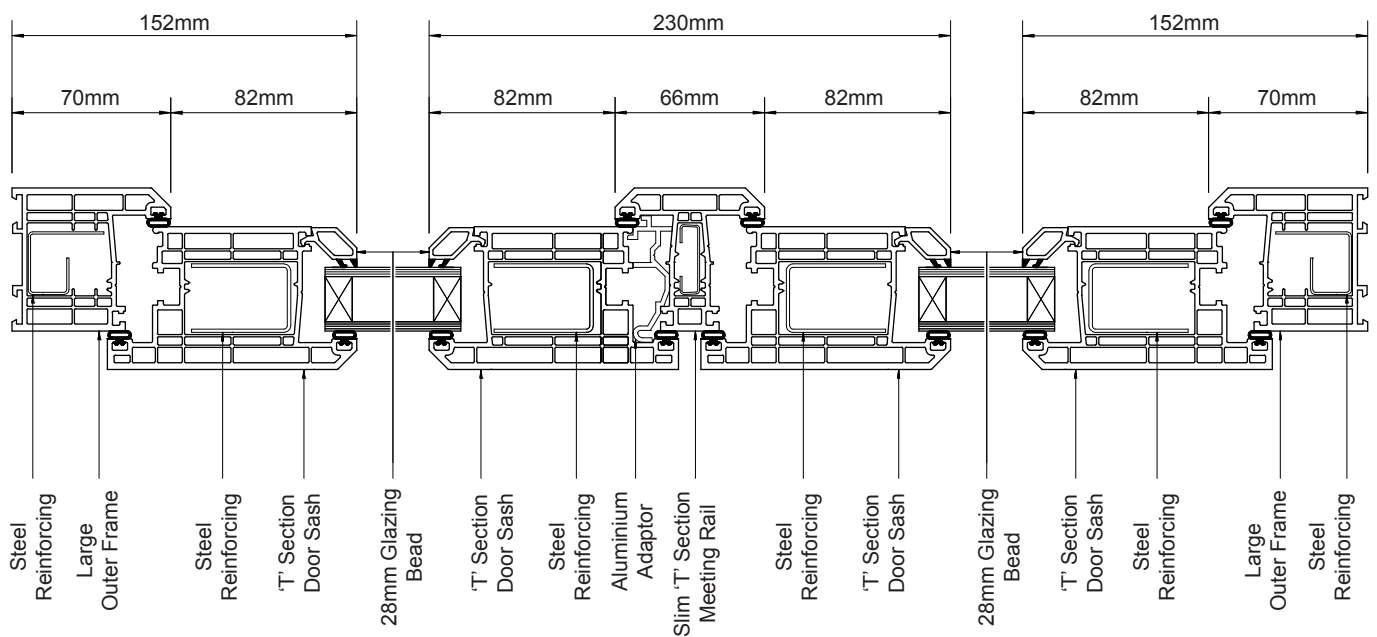

Note : All reinforcements shown are for diagramatical purposes only. For application, see pages Int.7 - Gen.7



ELITE 63 - GENERAL ASSEMBLIES

BI-FOLDING DOORS

TYPICAL OPEN-IN BI-FOLDING DOORS

SPECIFICATION

3 Bi-Folding Doors
 Large Outer Frame
 'Z' Section Door Sash
 'T' Section Door Sash
 Slim 'T' Meeting Rail
 28mm Glazing Bead
 Steel/Aluminium Reinforcing

NOTE :- Bi-Folding Doors are available in 3, 4, 5, 6 & 7 door options in various configurations

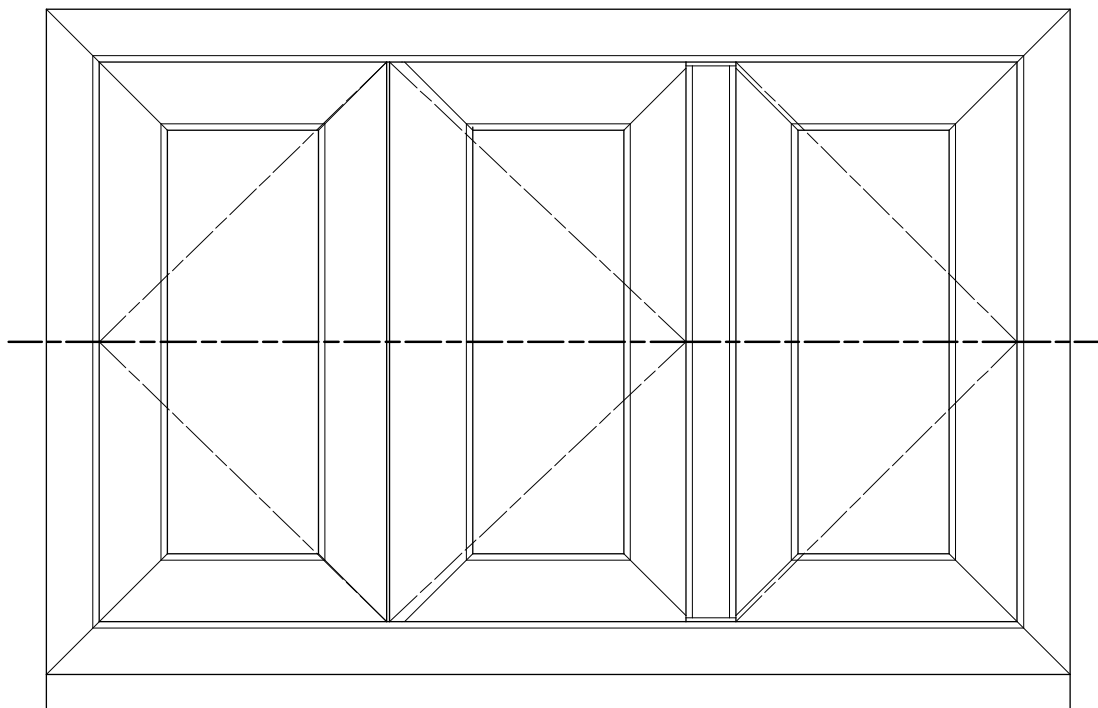
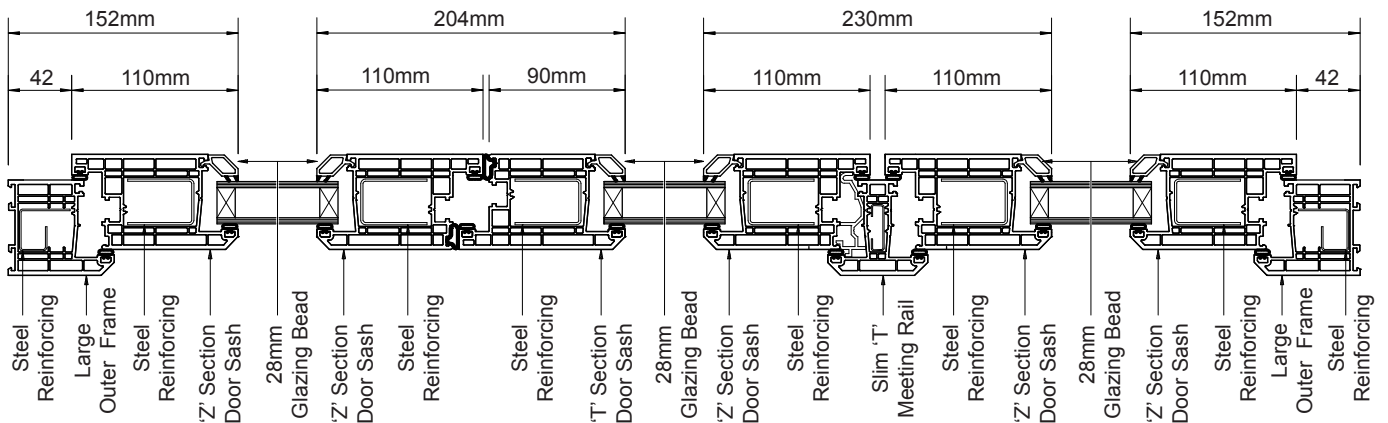
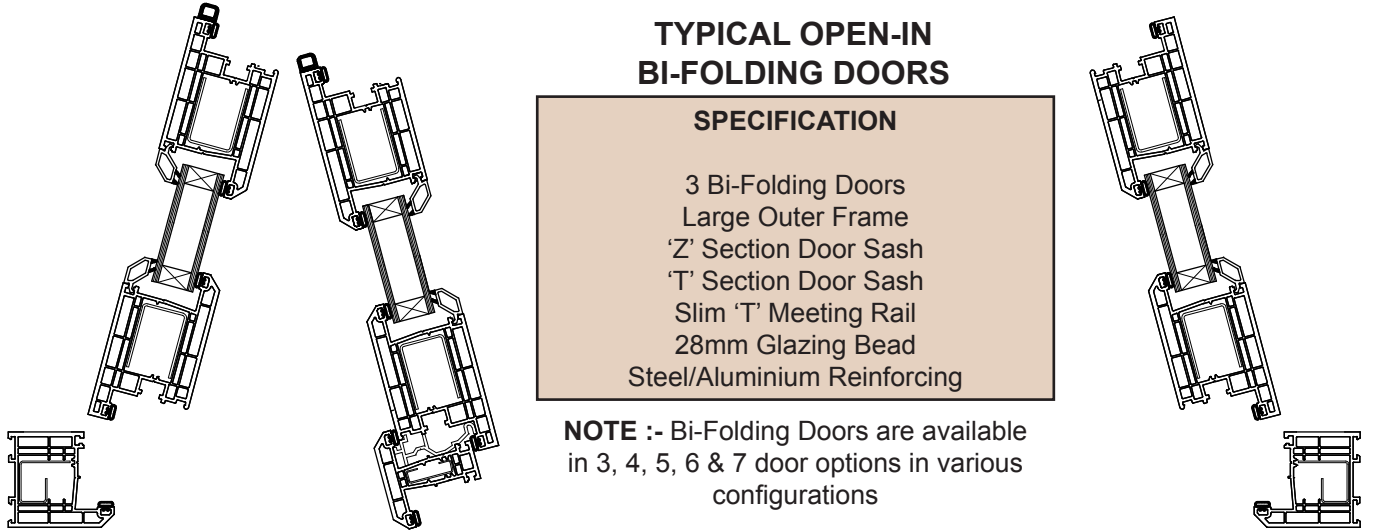

Note : All reinforcements shown are for diagrammatical purposes only. For application, see pages Int.7 - Gen.7



CILLS - PROFILE GUIDE

85mm CILLS

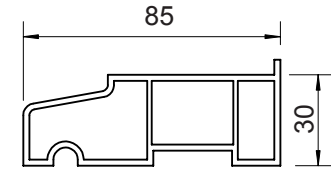

C085 85mm Bull Nose Cill

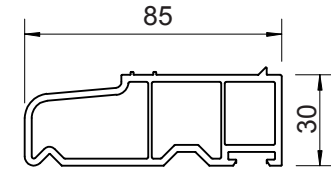

C086 85mm Bull Nose Cill

110mm CILL

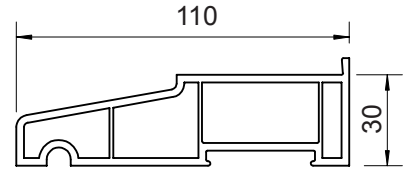

C110 110mm Bull Nose Cill

150mm CILLS

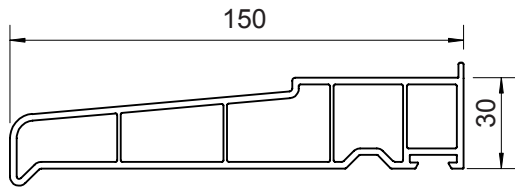

C150 150mm Classic Nose Cill

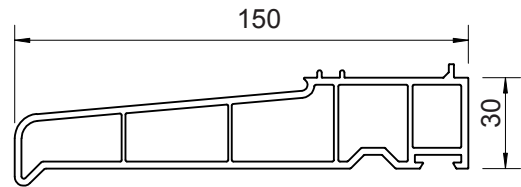

C151 150mm Classic Nose Cill

180mm CILLS

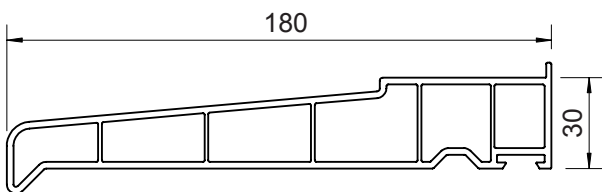

C180 180mm Classic Nose Cill

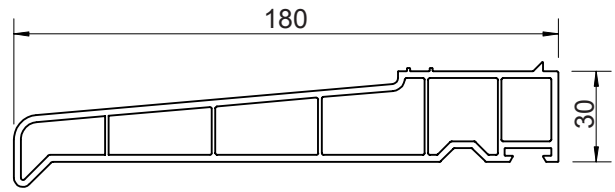

C181 180mm Classic Nose Cill

225mm CILL

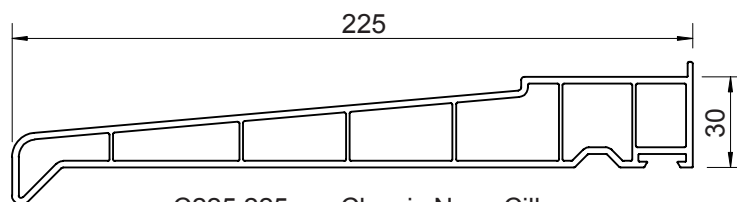

C225 225mm Classic Nose Cill

Note : All cills suit Elite 70, Reversible 70, Elite 63 and the Ride Over Patio.



VERTICAL SLIDER - PROFILE GUIDE

OUTER FRAME

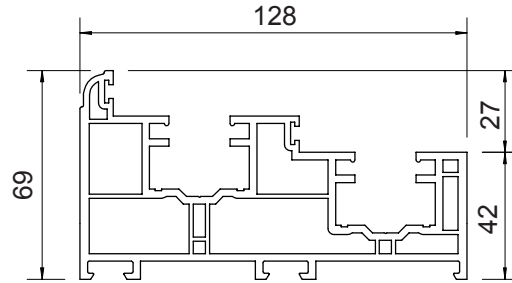

VS01 Outer Frame

CILLS

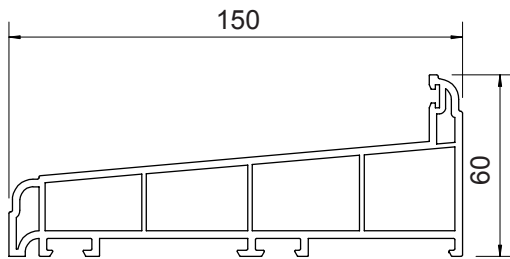

VS02 Cill

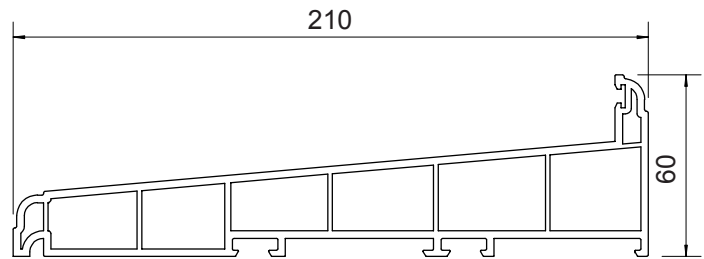

VS14 Extended Cill

SASHES

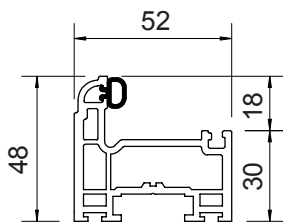

VS03 Small Sash

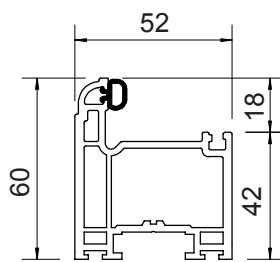

VS04 Standard Sash

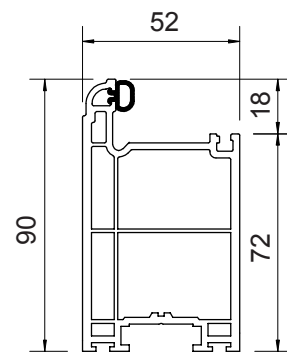

VS05 Deep Bottom Rail

INTERLOCKS & STOP

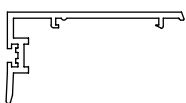

VS09 Interlock

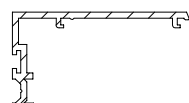

VSR9
Aluminium Interlock



VS10 Sash Stop

BEADS & ANCILLARIES

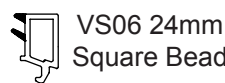

VS06 24mm
Square Bead



VS11 Small
Georgian Bar

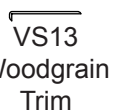

VS13
Woodgrain
Trim

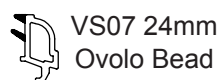

VS07 24mm
Ovolo Bead

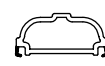

VS12 Large
Georgian Bar

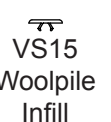

VS15
Woolpile
Infill



VERTICAL SLIDER - GENERAL ASSEMBLIES

STANDARD CONFIGURATION (VERTICAL SECTION)

TYPICAL VERTICAL SLIDING WINDOW

SPECIFICATION

Small Top Sash
Standard Bottom Sash
Deep Bottom Rail Sash
Co-extruded 24mm Glazing Bead
Standard Cill
Steel/Aluminium Reinforcing

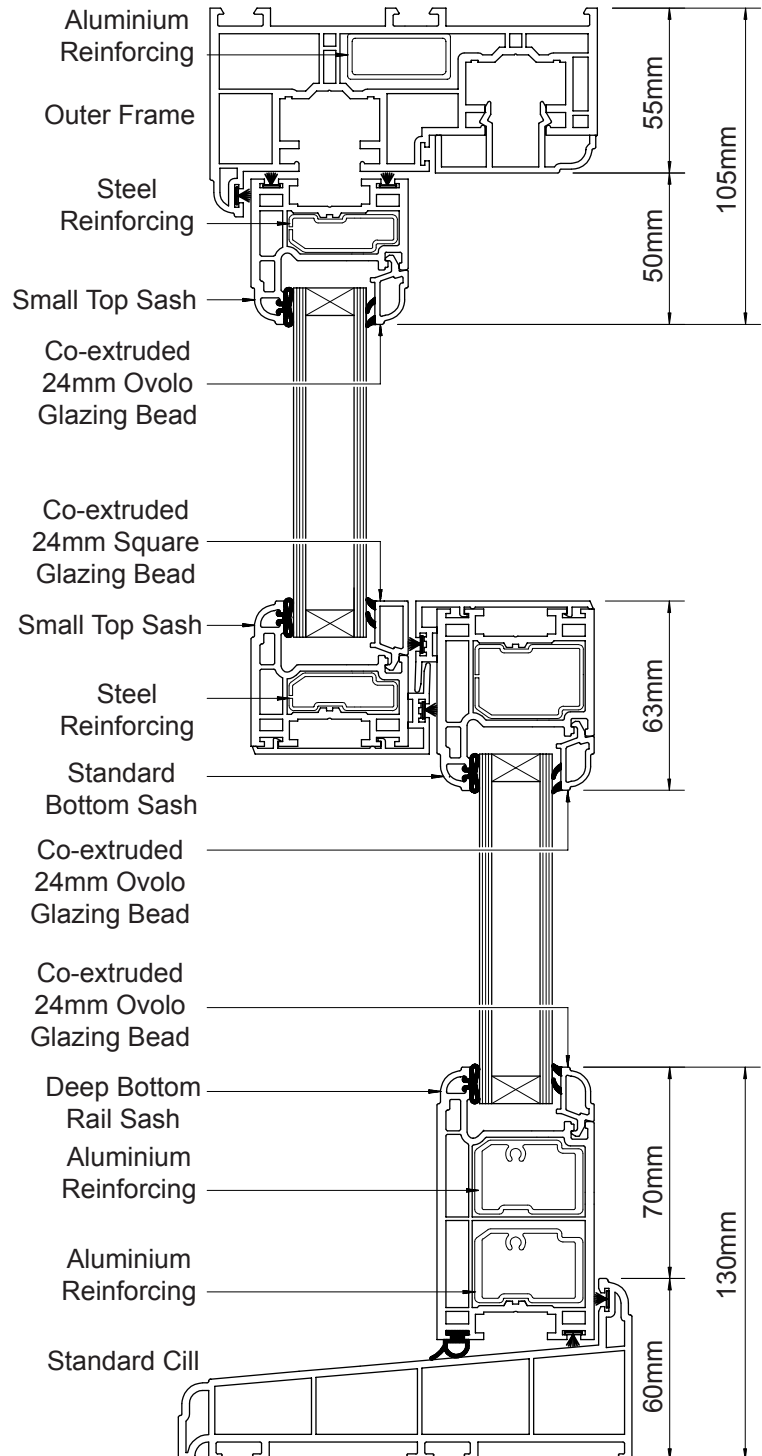
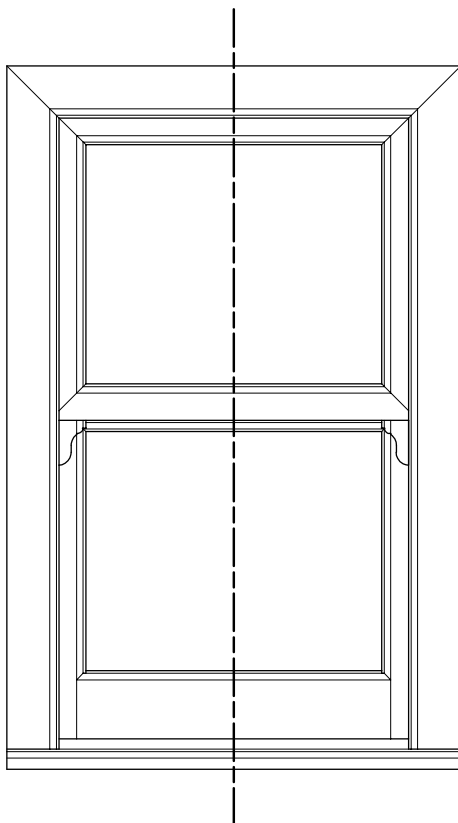

Note : All reinforcements shown are for diagrammatical purposes only. For application, see page Int.7



VERTICAL SLIDER - GENERAL ASSEMBLIES

STANDARD CONFIGURATION (HORIZONTAL SECTION)

TYPICAL VERTICAL SLIDING WINDOW

SPECIFICATION

Small Top Sash
Standard Bottom Sash
Co-extruded 24mm Glazing Bead
Steel/Aluminium Reinforcing

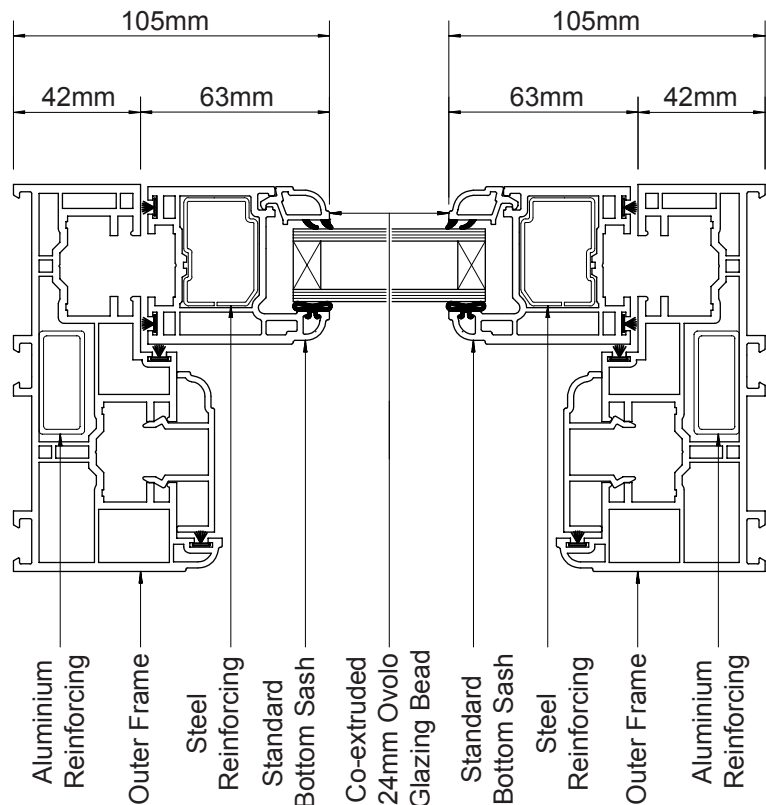
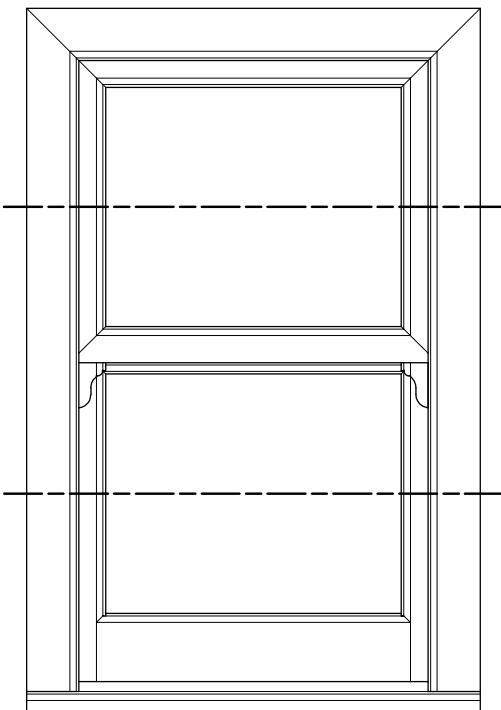
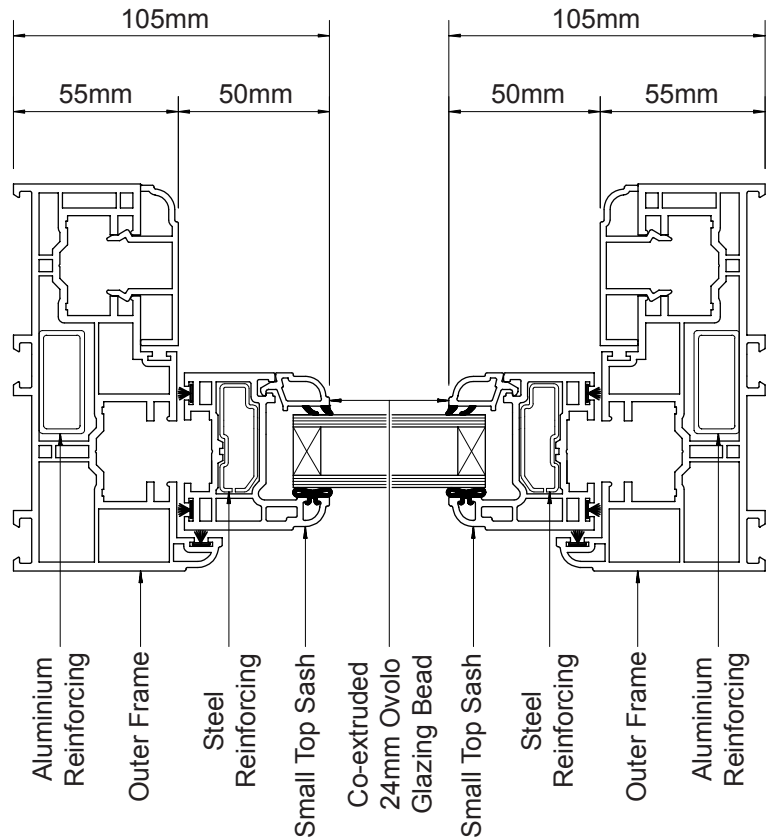

Note : All reinforcements shown are for diagramatical purposes only. For application, see page Int.7



VERTICAL SLIDER - GENERAL ASSEMBLIES

HEAVY DUTY CONFIGURATION (VERTICAL SECTION)

TYPICAL VERTICAL SLIDING WINDOW

SPECIFICATION

Standard Top Sash
 Standard Bottom Sash
 Deep Bottom Rail Sash
 Co-extruded 24mm Glazing Bead
 Standard Cill
 Steel/Aluminium Reinforcing

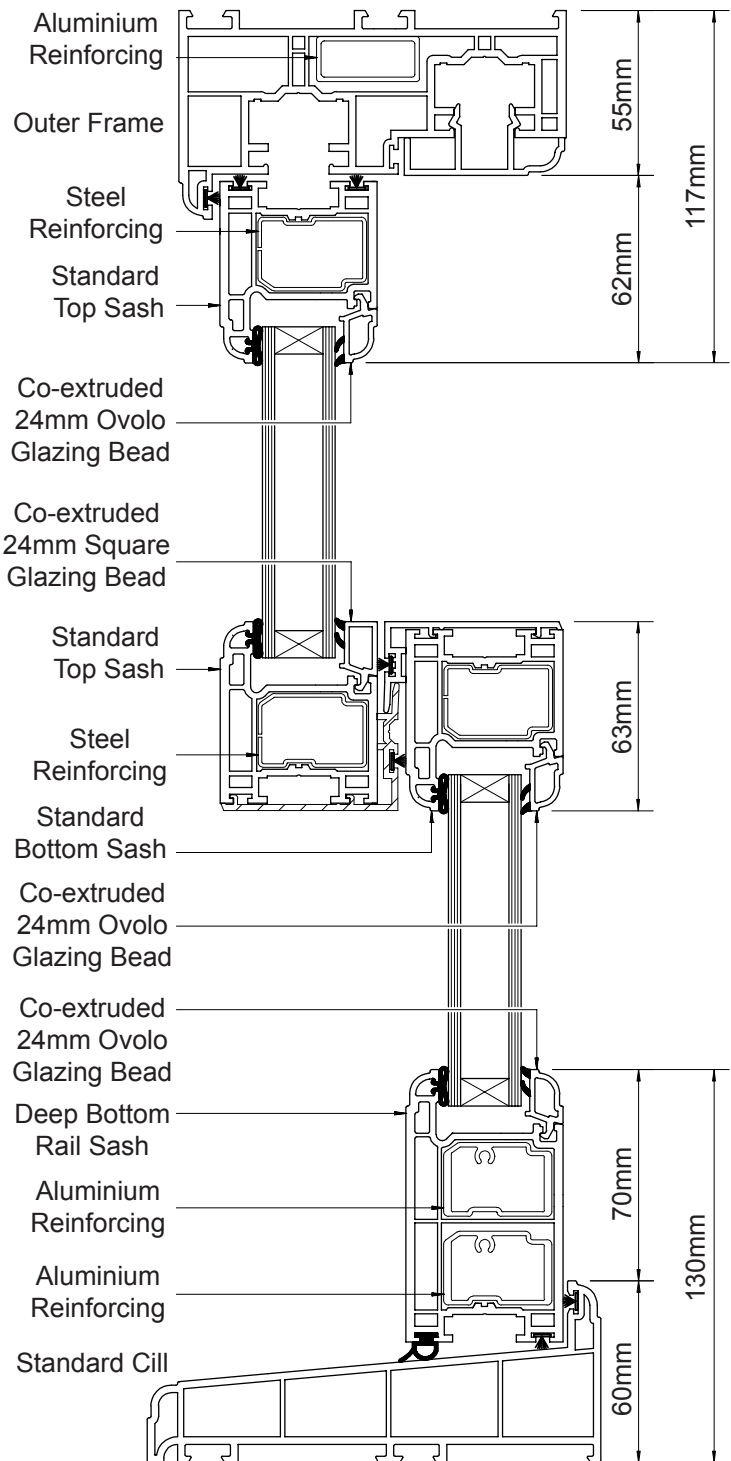
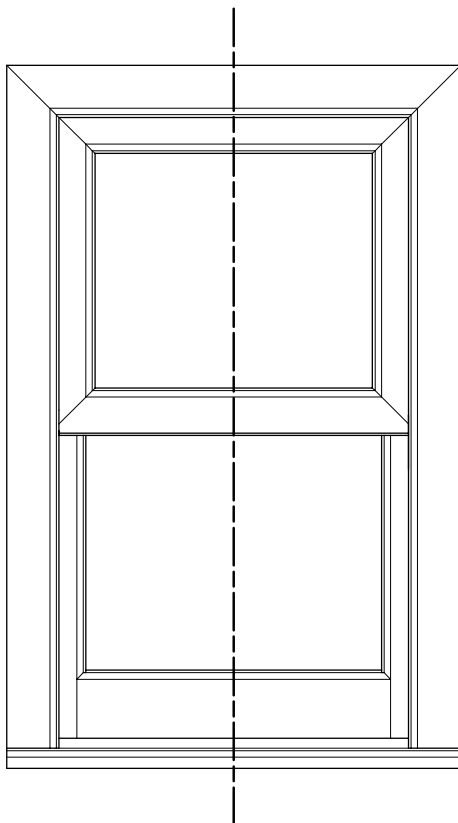

Note : All reinforcements shown are for diagramatical purposes only. For application, see page Int.7



VERTICAL SLIDER - GENERAL ASSEMBLIES

HEAVY DUTY CONFIGURATION (HORIZONTAL SECTION)

TYPICAL VERTICAL SLIDING WINDOW

SPECIFICATION

Standard Top Sash
Standard Bottom Sash
Co-extruded 24mm Glazing Bead
Steel/Aluminium Reinforcing

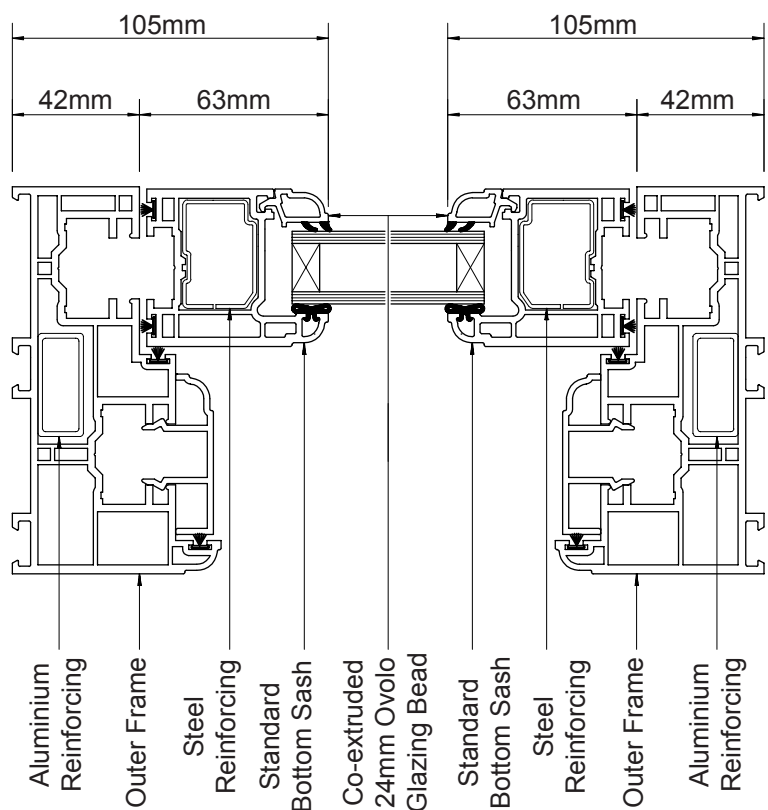
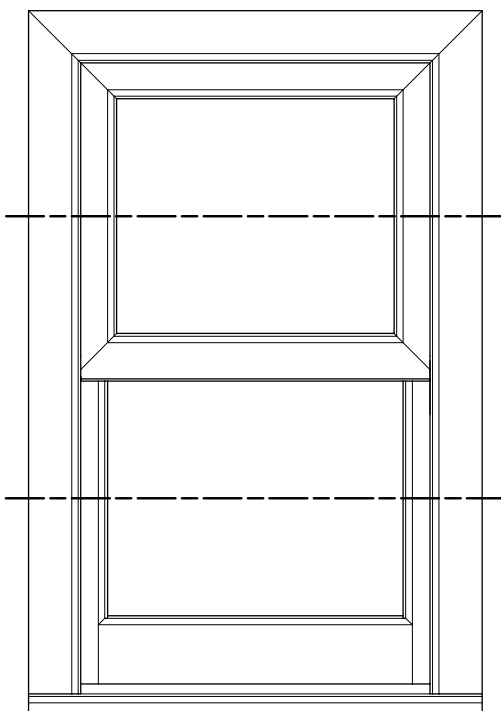
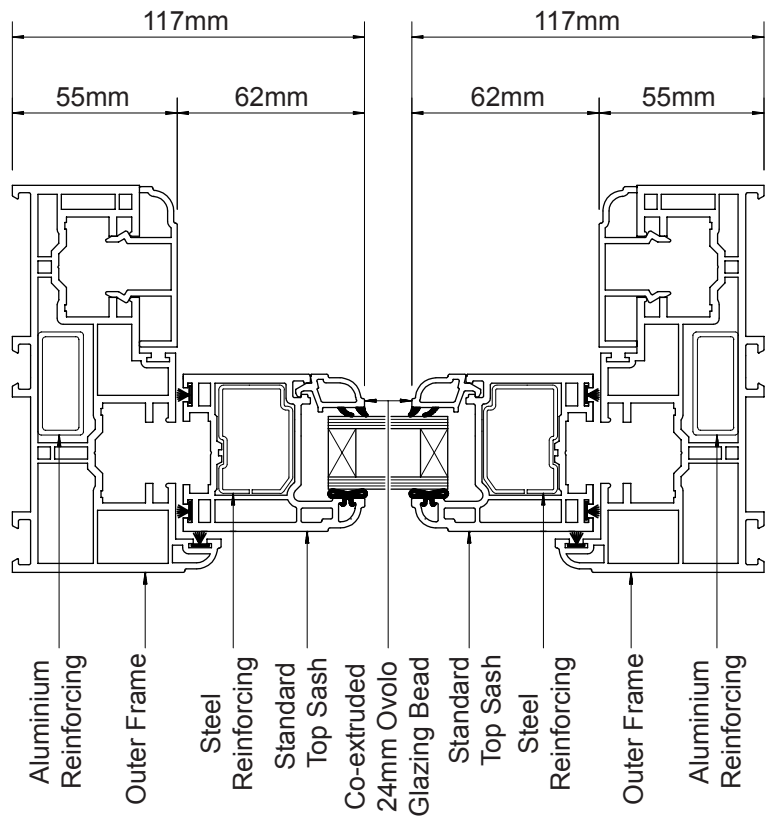

Note : All reinforcements shown are for diagramatical purposes only. For application, see page Int.7



RIDE OVER PATIO - PROFILE GUIDE

MAIN PROFILES

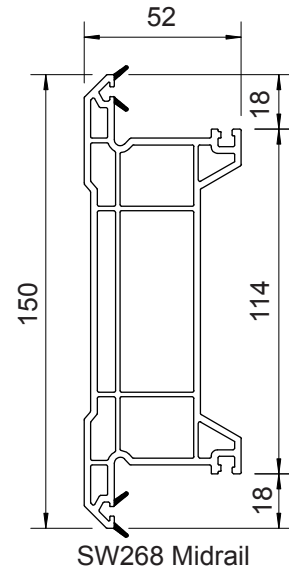
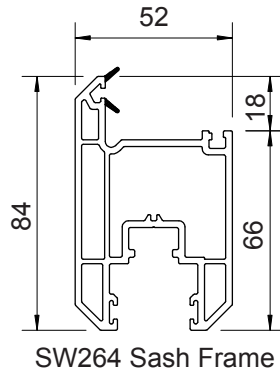
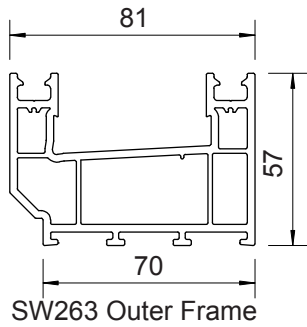

COVERS

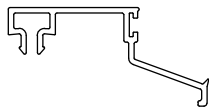

SW267 Frame Cover



SW262 Drainage Cover



SW269 Interlock Cover



SW261 Track Cover



SW265 Woolpile Carrier

ALUMINIUM

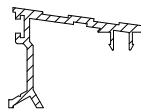

SWR267 Threshold

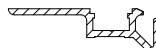

SWR269A Interlock

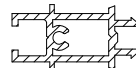

SWR271
3 & 4 Pane Adaptor

TRACK



SWR261S
Stainless
Steel Track

BEADS/PACKERS



SW266
28mm Bead



X60
24mm Bead

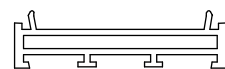

SW741 15mm
Frame Packer

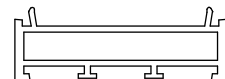

SW742 20mm
Frame Packer

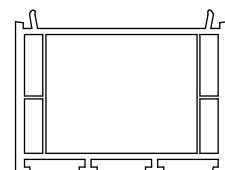

SW743 50mm
Frame Packer



RIDE OVER PATIO - GENERAL ASSEMBLIES

EXTERNAL SLIDING SASH

TYPICAL RIDE OVER SLIDING PATIO

SPECIFICATION

Outer Frame
Sliding Sash
Midrail
Co-extruded 28mm Glazing Bead
150mm Cill
Steel/Aluminium Reinforcing

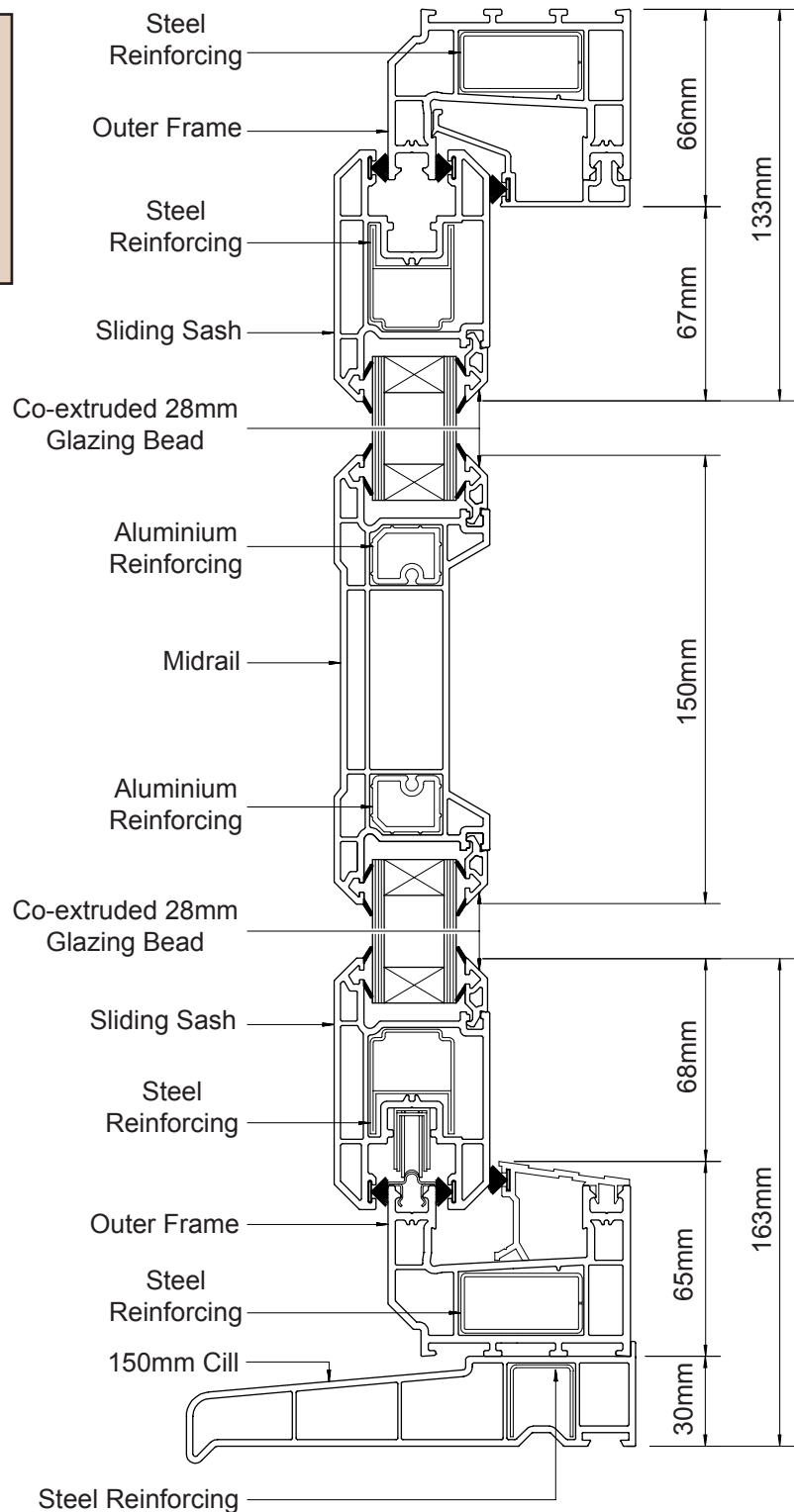
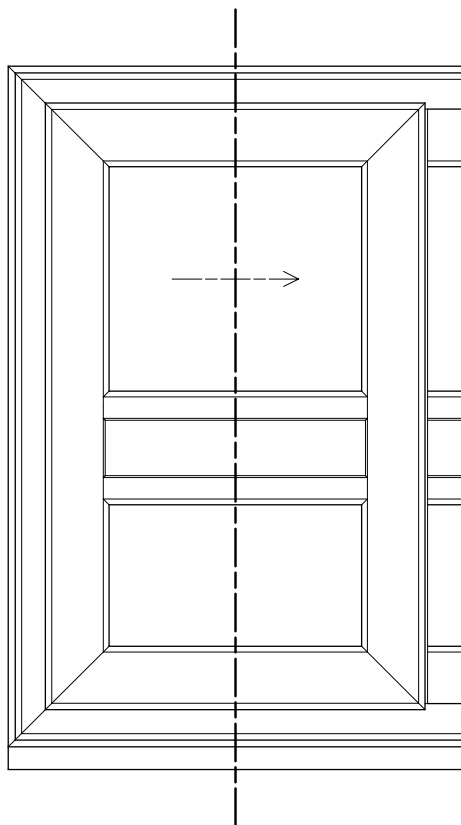

Note : All reinforcements shown are for diagramatical purposes only.



RIDE OVER PATIO - GENERAL ASSEMBLIES

INTERNAL FIXED SASH

TYPICAL RIDE OVER SLIDING PATIO

SPECIFICATION

Outer Frame
Fixed Sash
Co-extruded 28mm Glazing Bead
150mm Cill
Steel/Aluminium Reinforcing

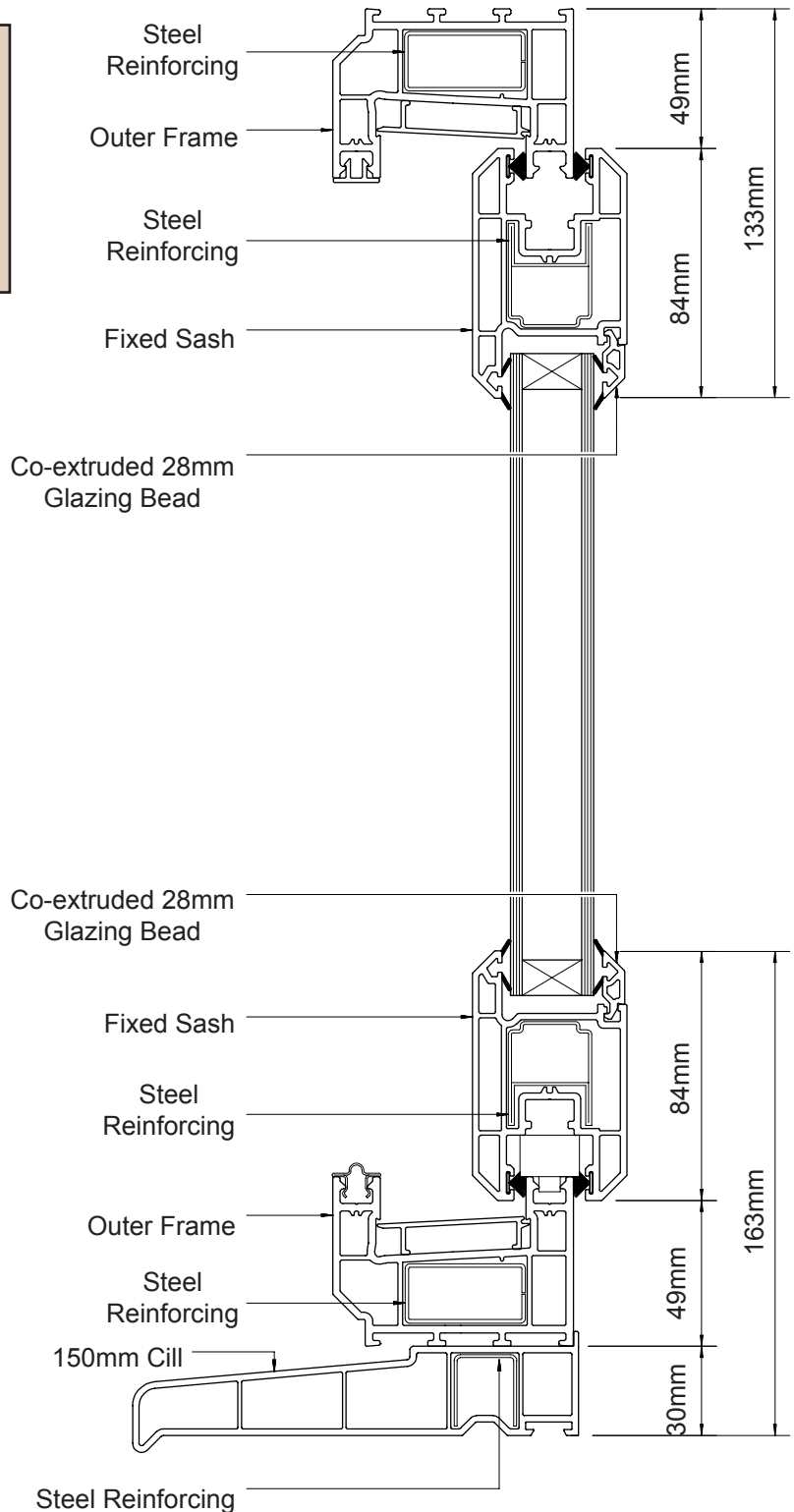
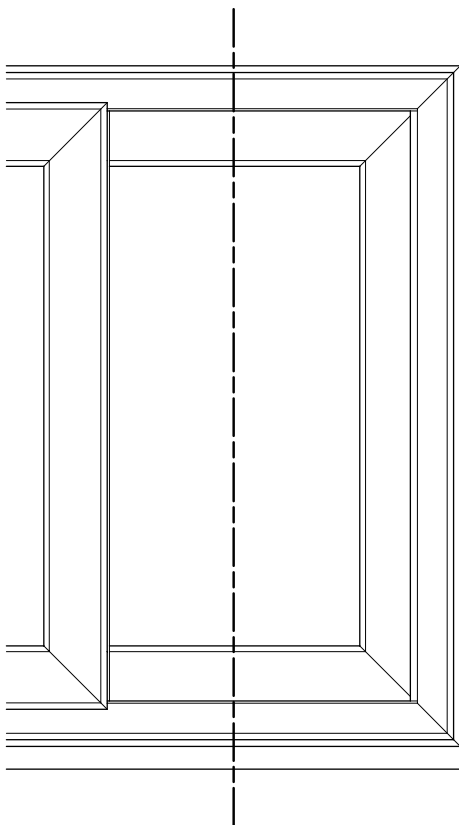

Note : All reinforcements shown are for diagrammatical purposes only.



RIDE OVER PATIO - GENERAL ASSEMBLIES

2 PANE CONFIGURATION

TYPICAL RIDE OVER SLIDING PATIO

SPECIFICATION

Outer Frame
Sliding/Fixed Sash
Co-extruded 28mm Glazing Bead
Steel/Aluminium Reinforcing

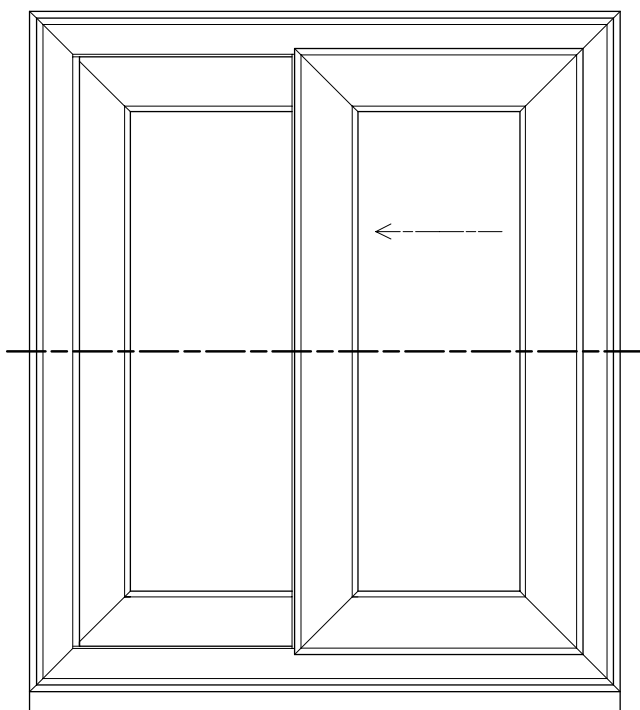
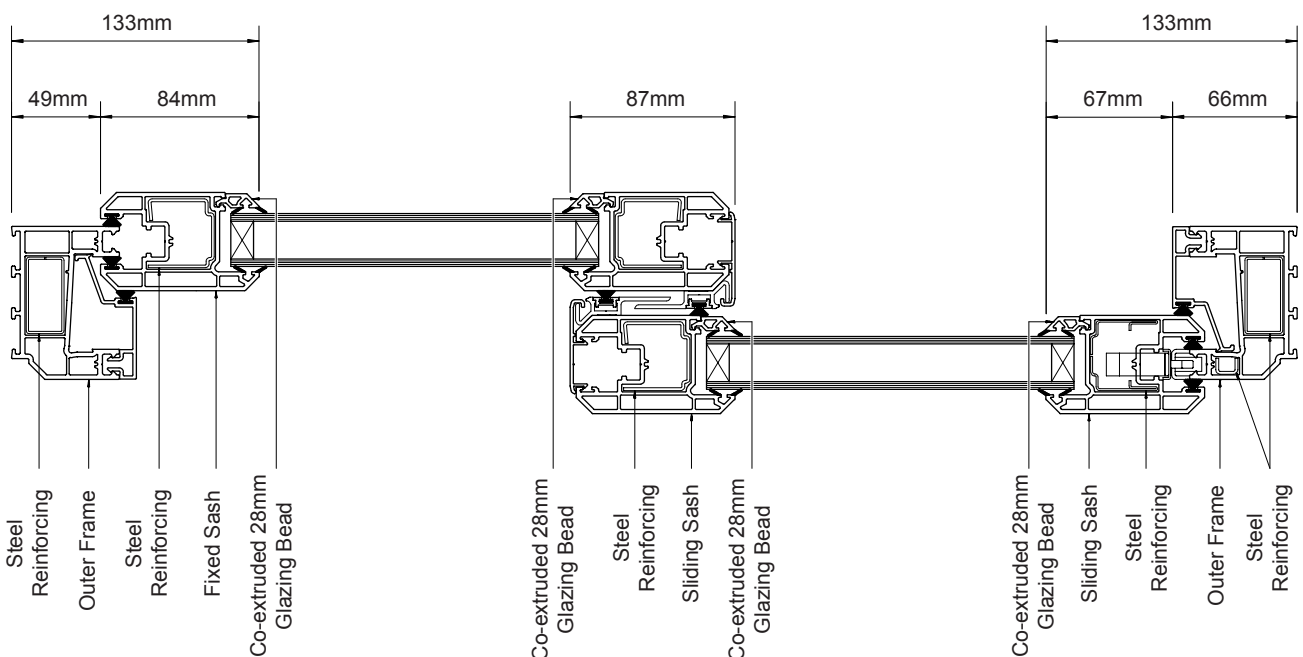

Note : All reinforcements shown are for diagrammatical purposes only.



RIDE OVER PATIO - GENERAL ASSEMBLIES

PANE CONFIGURATION

TYPICAL RIDE OVER SLIDING PATIO

SPECIFICATION

Outer Frame
Sliding/Fixed Sash
Co-extruded 28mm Glazing Bead
Steel/Aluminium Reinforcing

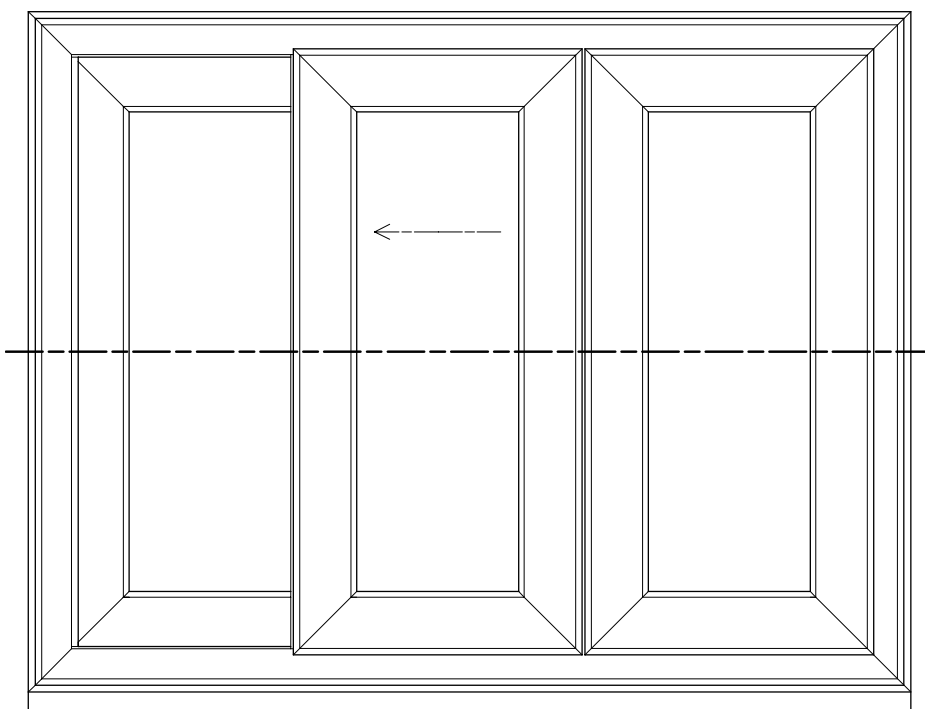
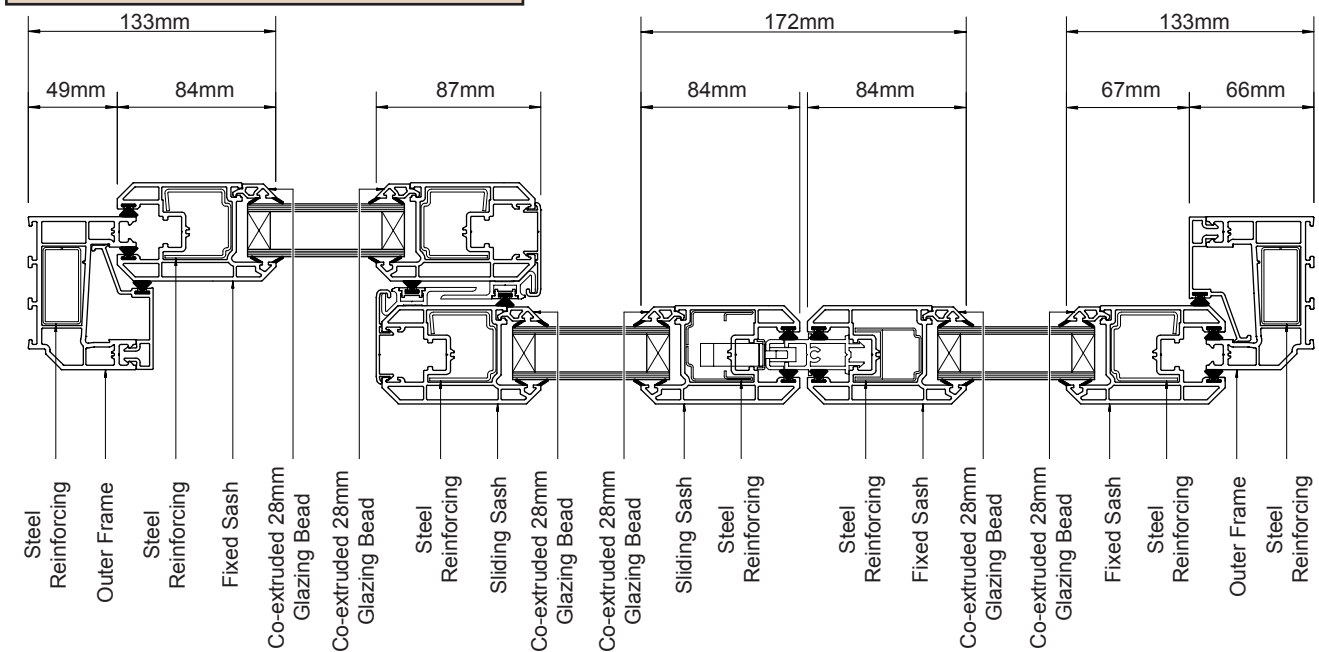

Note : All reinforcements shown are for diagramatical purposes only.



RIDE OVER PATIO - GENERAL ASSEMBLIES

4 PANE CONFIGURATION

TYPICAL RIDE OVER SLIDING PATIO

SPECIFICATION

Outer Frame
Sliding/Fixed Sash
Co-extruded 28mm Glazing Bead
Steel/Aluminium Reinforcing

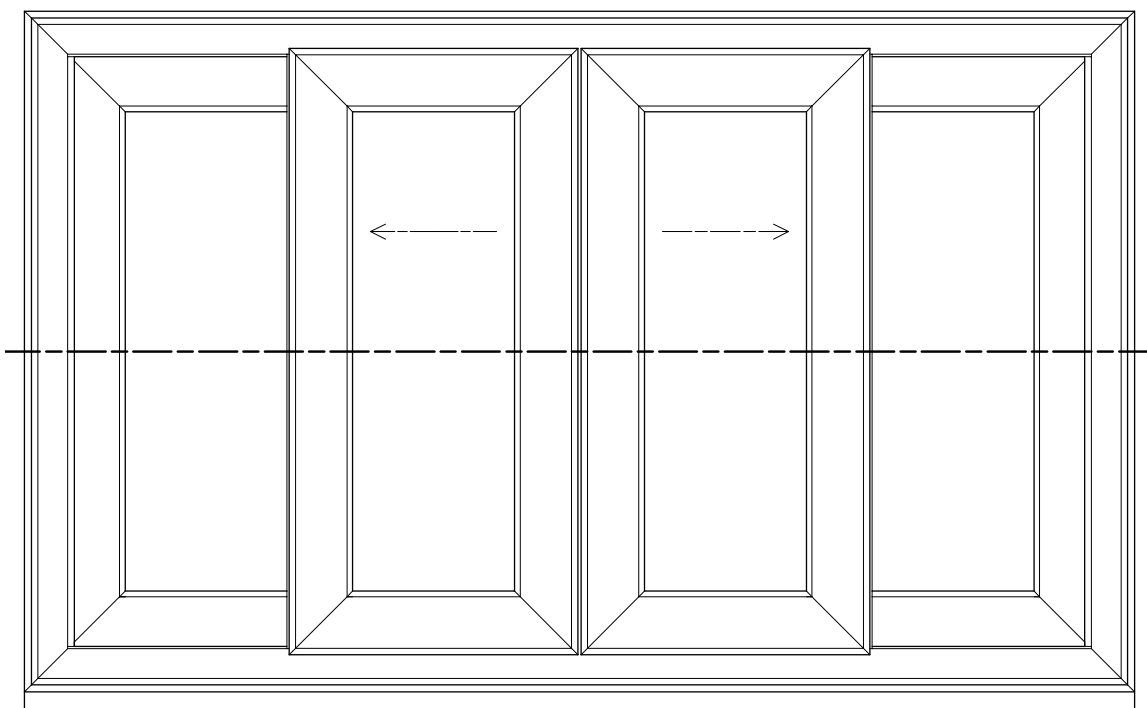
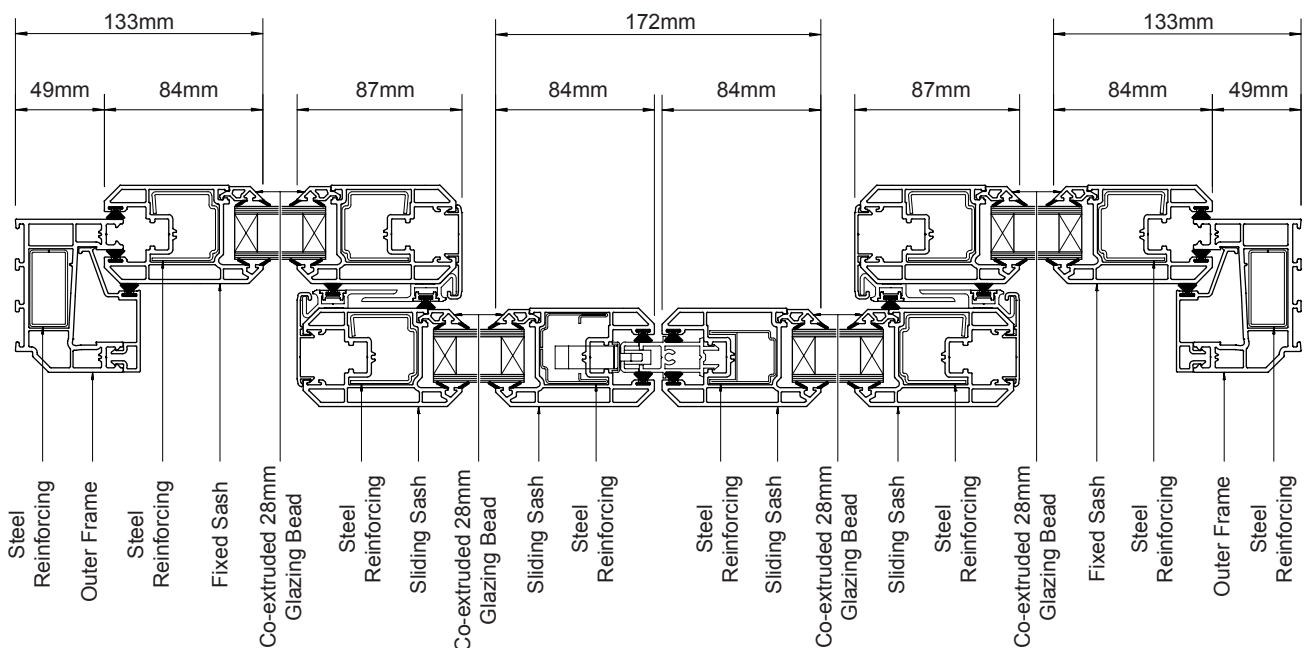

Note : All reinforcements shown are for diagramatical purposes only.



FORMER - PROFILE GUIDE

CAVITY CLOSER BOXES

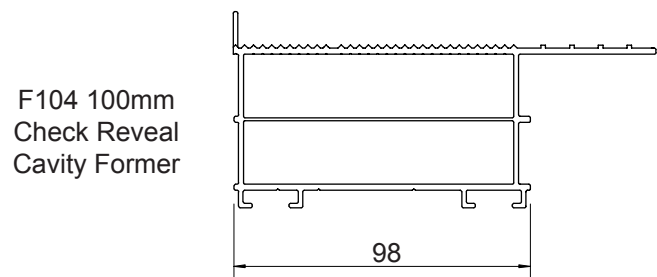
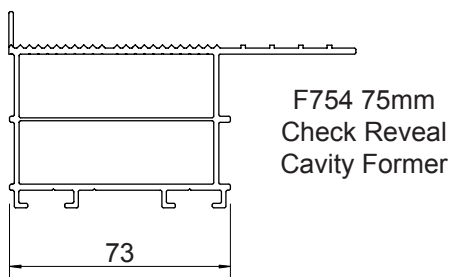
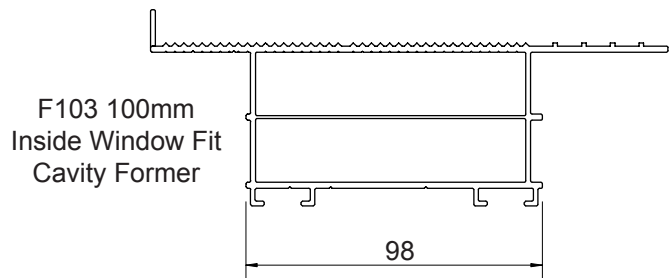
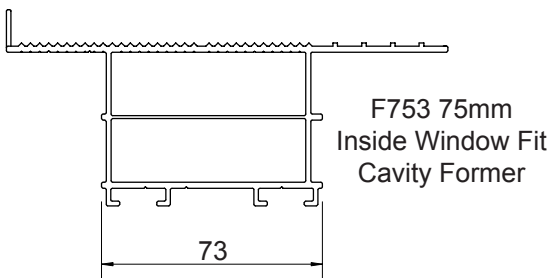
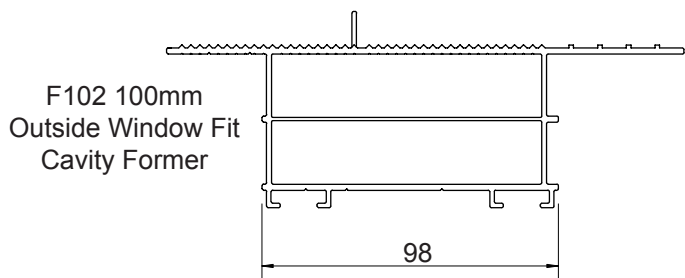
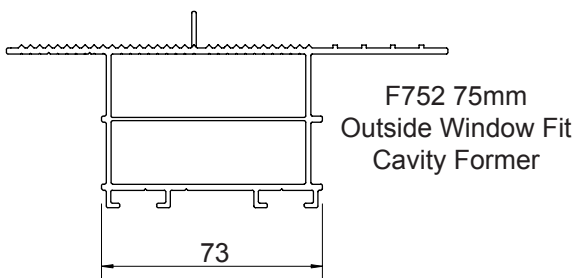
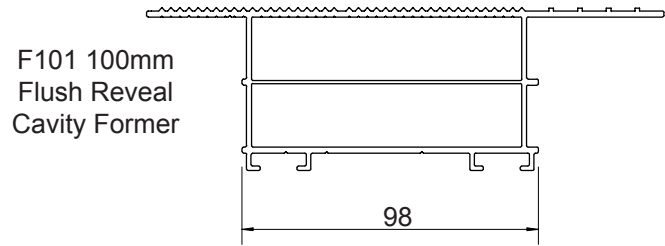
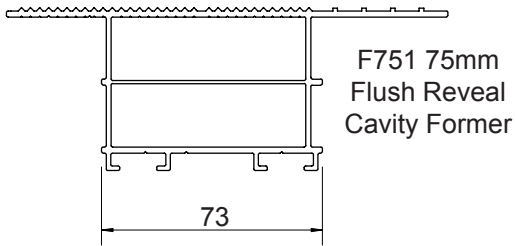

HEAD VENTS

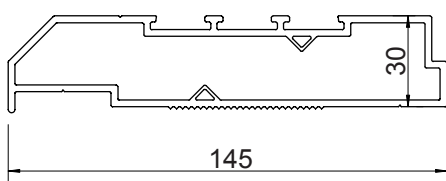

F031
Flush Reveal
Overhead Vent

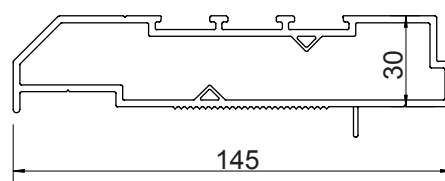

F032
Outside Window Fit
Overhead Vent

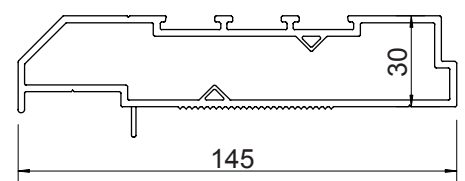

F033
Inside Window Fit
Overhead Vent



FORMER - APPLICATION

CAVITY SIZES

The boxes are to suit 75mm and 100mm cavities as standard. Additional cavity widths can be accommodated, if required, with the addition of expanded polystyrene (EPS) sections bonded to the extrusions.

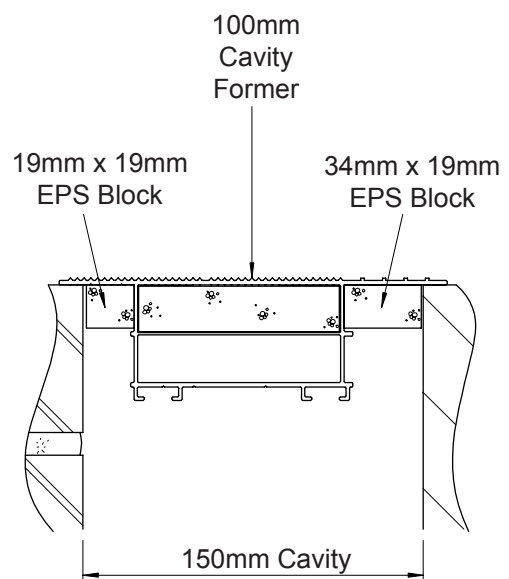
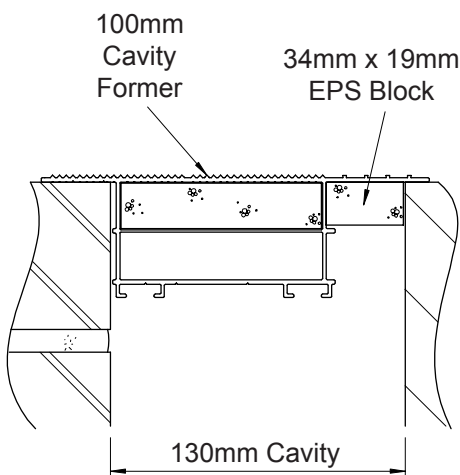
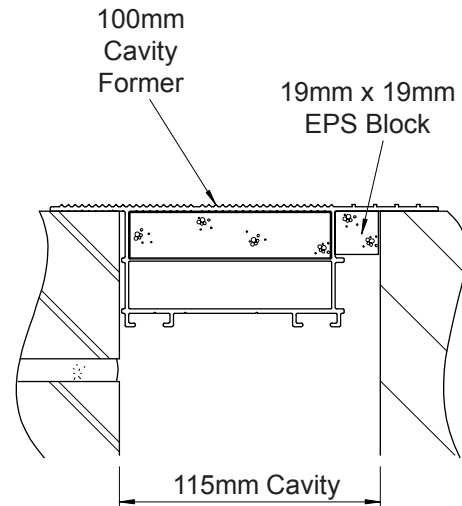
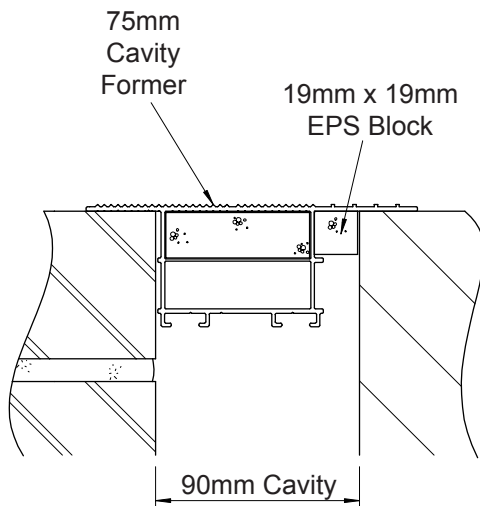

** Typical cavity sizes shown, alternative sizes can be accommodated by increasing or decreasing the EPS size.*



FORMER - GENERAL ASSEMBLIES

FLUSH REVEAL - 100mm CAVITY

100mm Cavity Shown.

Other cavity sizes can be accommodated. See Page F.2.

SPECIFICATION

100mm Flush Reveal Cavity Former
30mm Overhead Ventilator

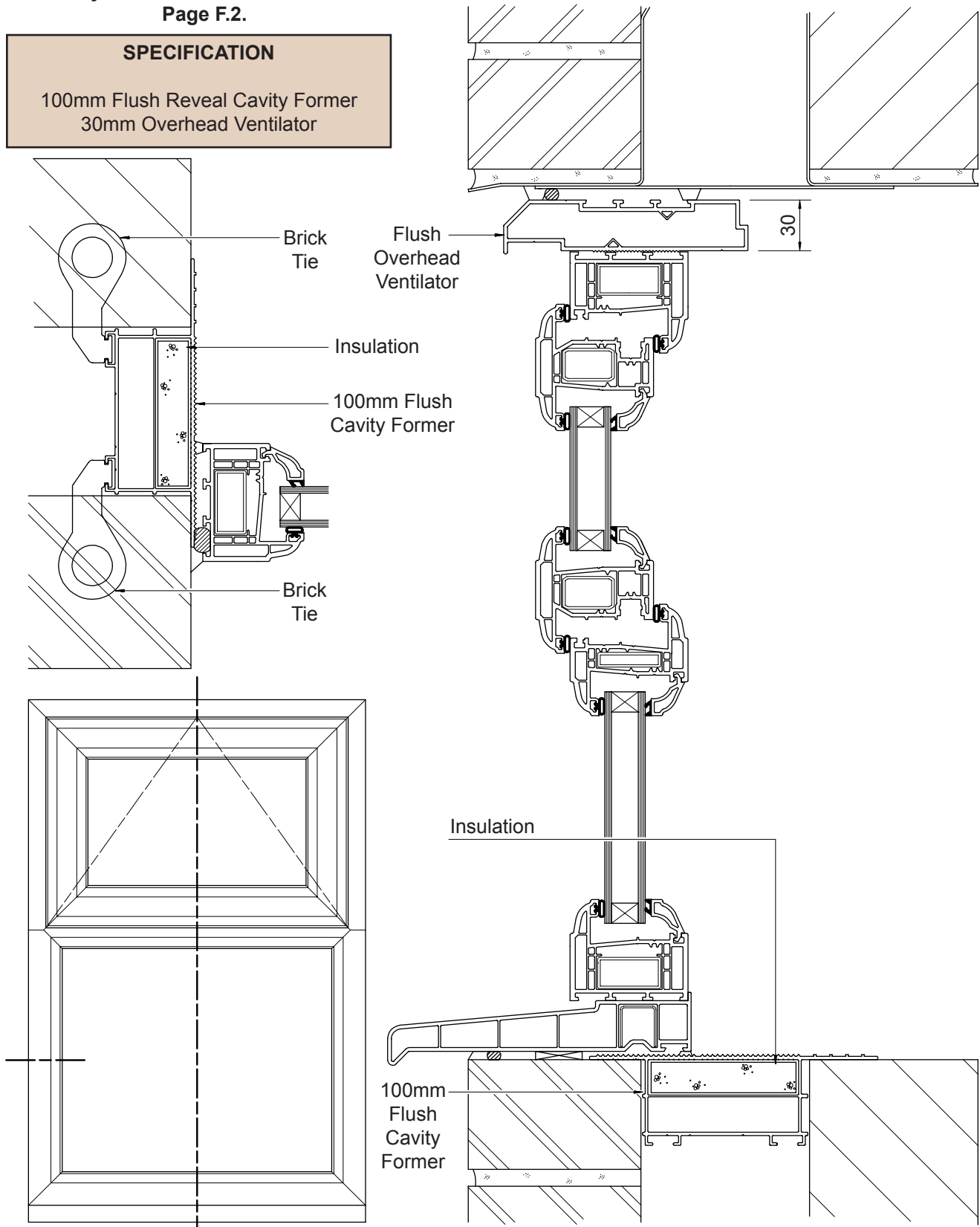



FORMER - GENERAL ASSEMBLIES

OUTSIDE WINDOW FIT - 100mm CAVITY

100mm Cavity Shown.

Other cavity sizes can be accommodated. See Page F.2.

SPECIFICATION

100mm Outside Fit Cavity Former
30mm Cavity Former Adaptor

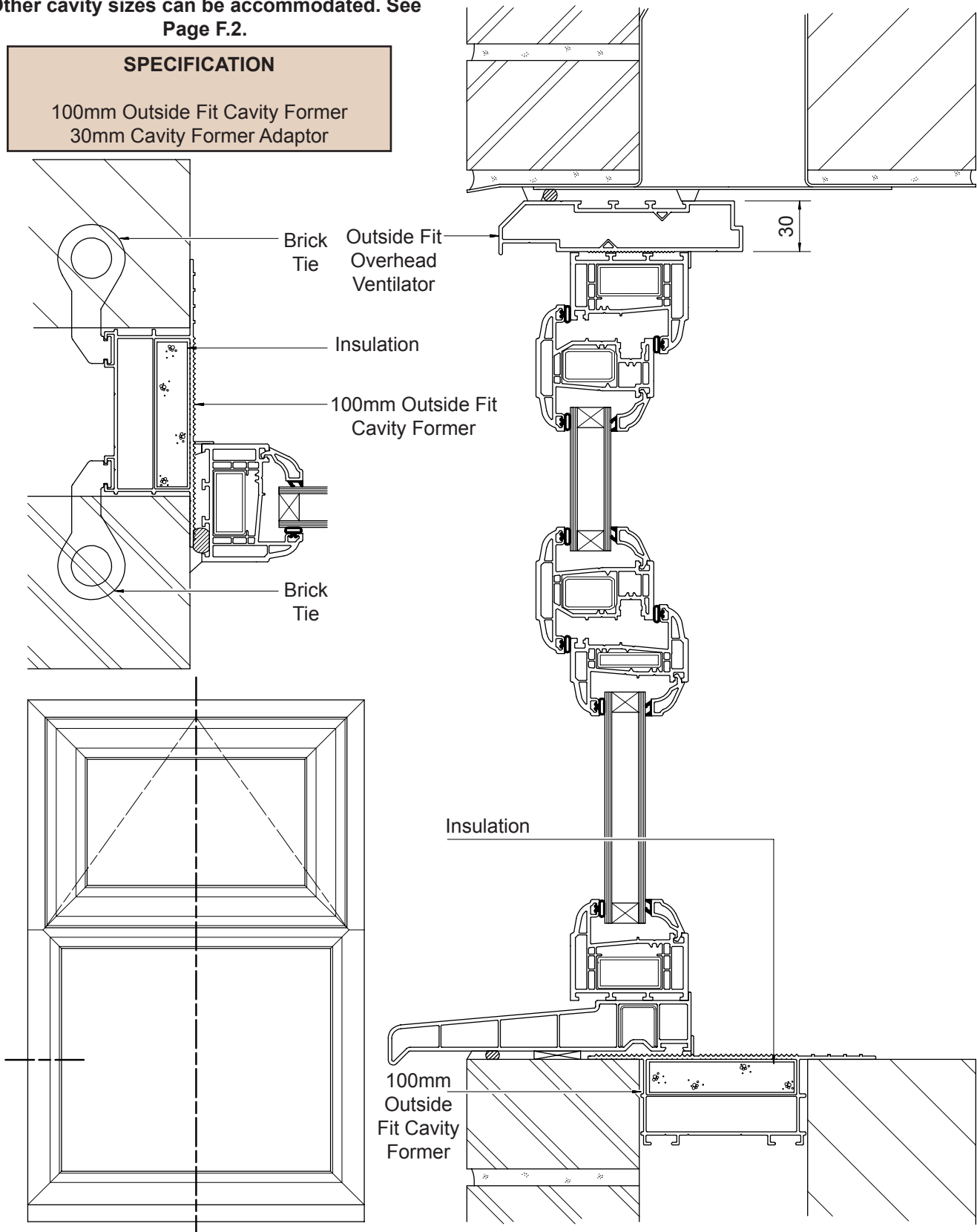

Note: When using the outside fit cavity former, the window can ONLY be installed from outside



FORMER - GENERAL ASSEMBLIES

INSIDE WINDOW FIT - 100mm CAVITY

100mm Cavity Shown.

Other cavity sizes can be accommodated. See Page F.2.

SPECIFICATION

100mm Inside Fit Cavity Former
30mm Overhead Ventilator

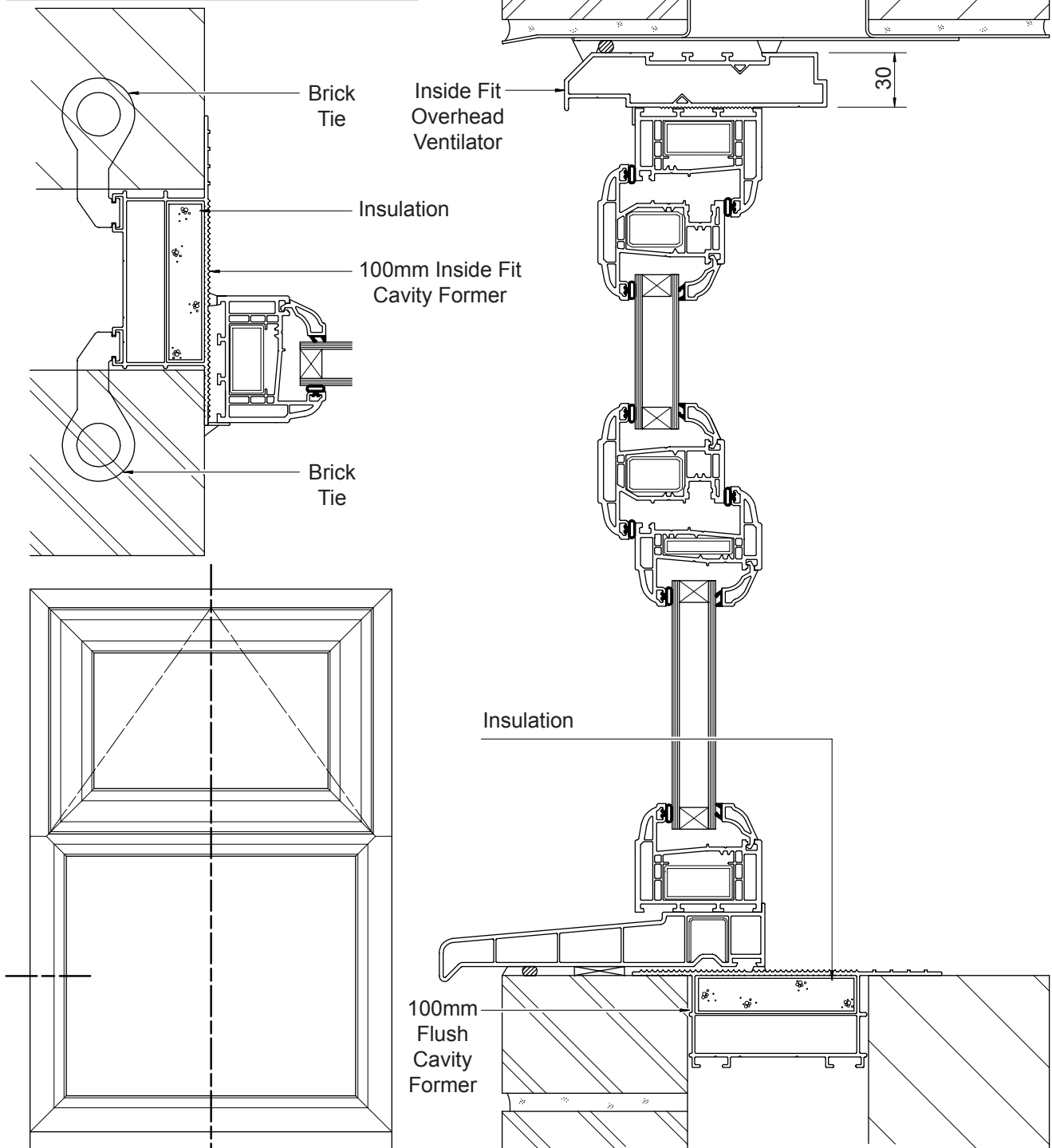

Note: When using the inside fit cavity former, the window can ONLY be installed from inside



FORMER - GENERAL ASSEMBLIES

CHECK REVEAL - 100mm CAVITY

100mm Cavity Shown.

Other cavity sizes can be accommodated. See Page F.2.

SPECIFICATION

100mm Check Reveal Cavity Former
30mm Overhead Ventilator

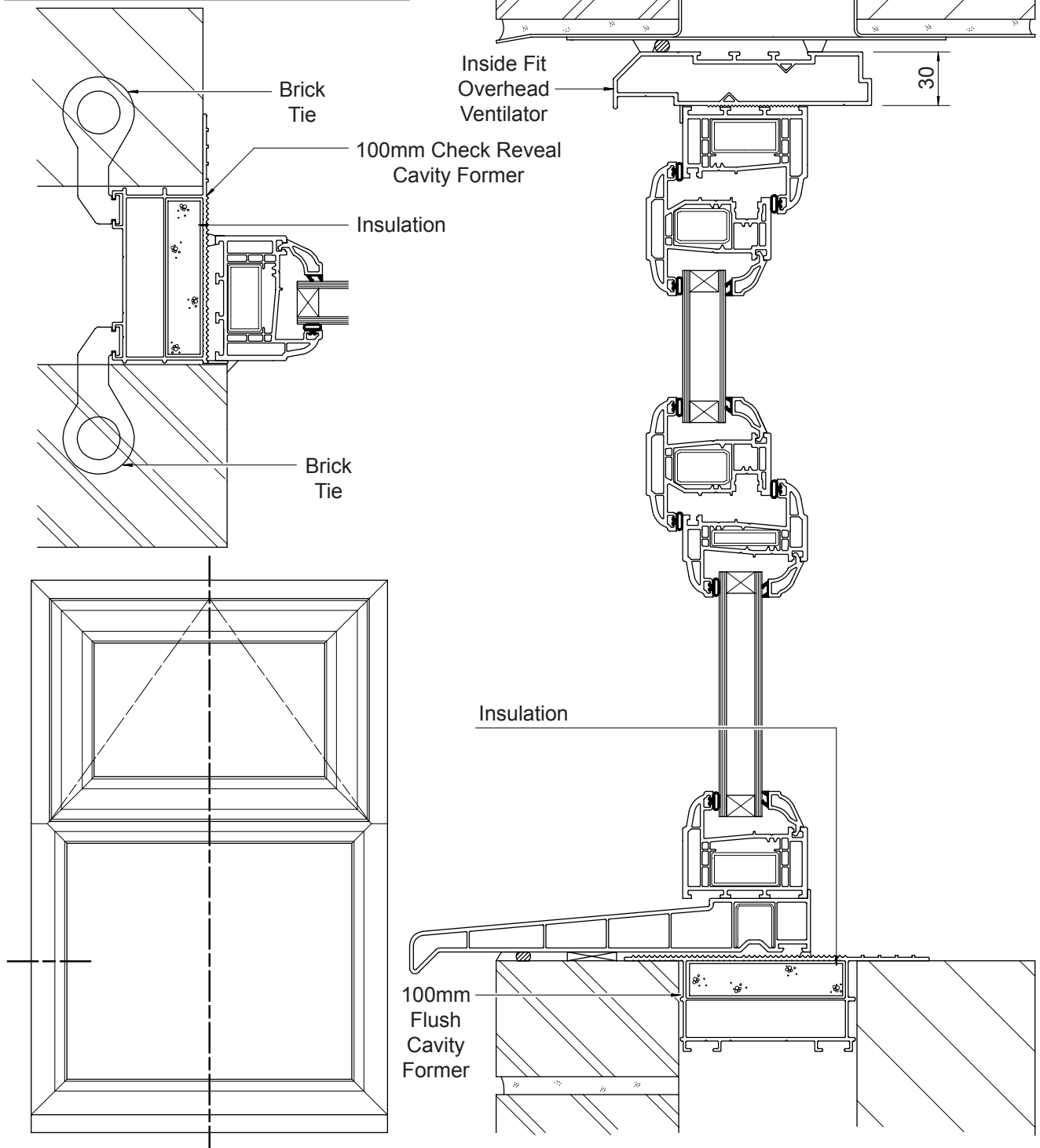

Note: When using the check reveal cavity former, the window can ONLY be installed from inside

Specifiers Guide Page F.6

spectus *n.* look, appearance, aspect

www.spectus.co.uk



CURTAIN WALLING - PROFILE GUIDE

TRANSOMS/MULLIONS

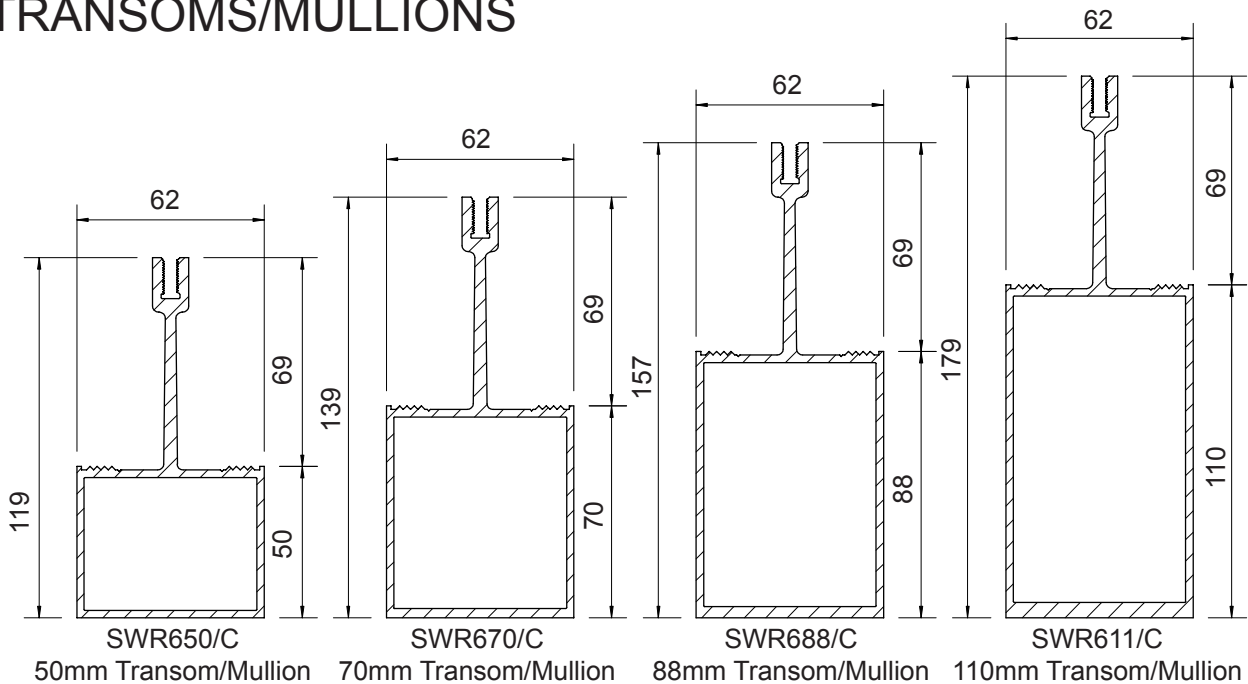

FACE CAPS & PRESSURE PLATES

POCKET FILLERS

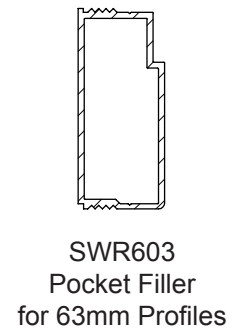
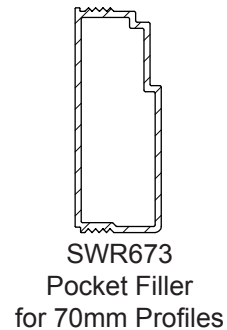
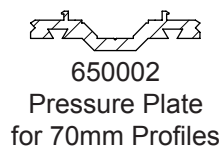
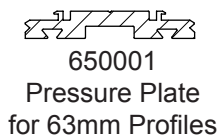
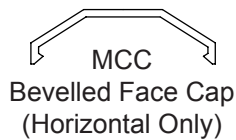

EXPANSION CAPS & EXPANSION FIXINGS

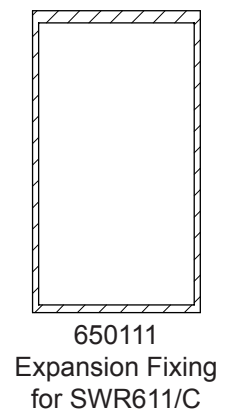
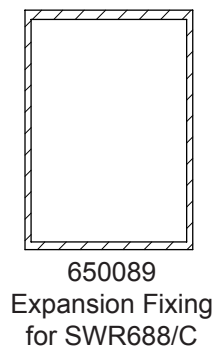
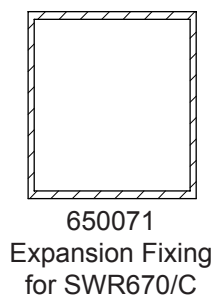
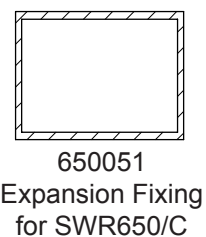
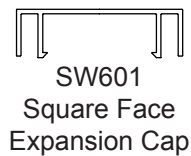



CURTAIN WALLING - GENERAL ASSEMBLIES

HEAD FIXING - 70mm PROFILES

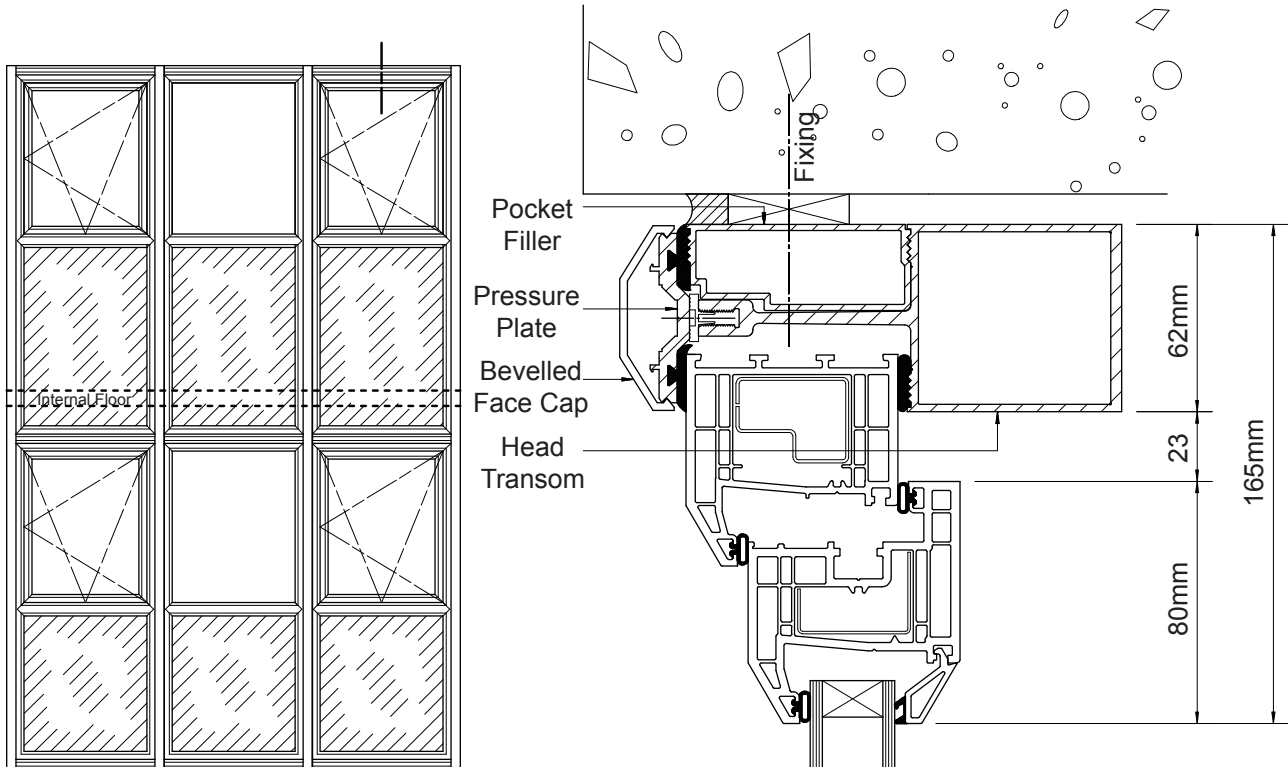

CILL FIXING - 70mm PROFILES

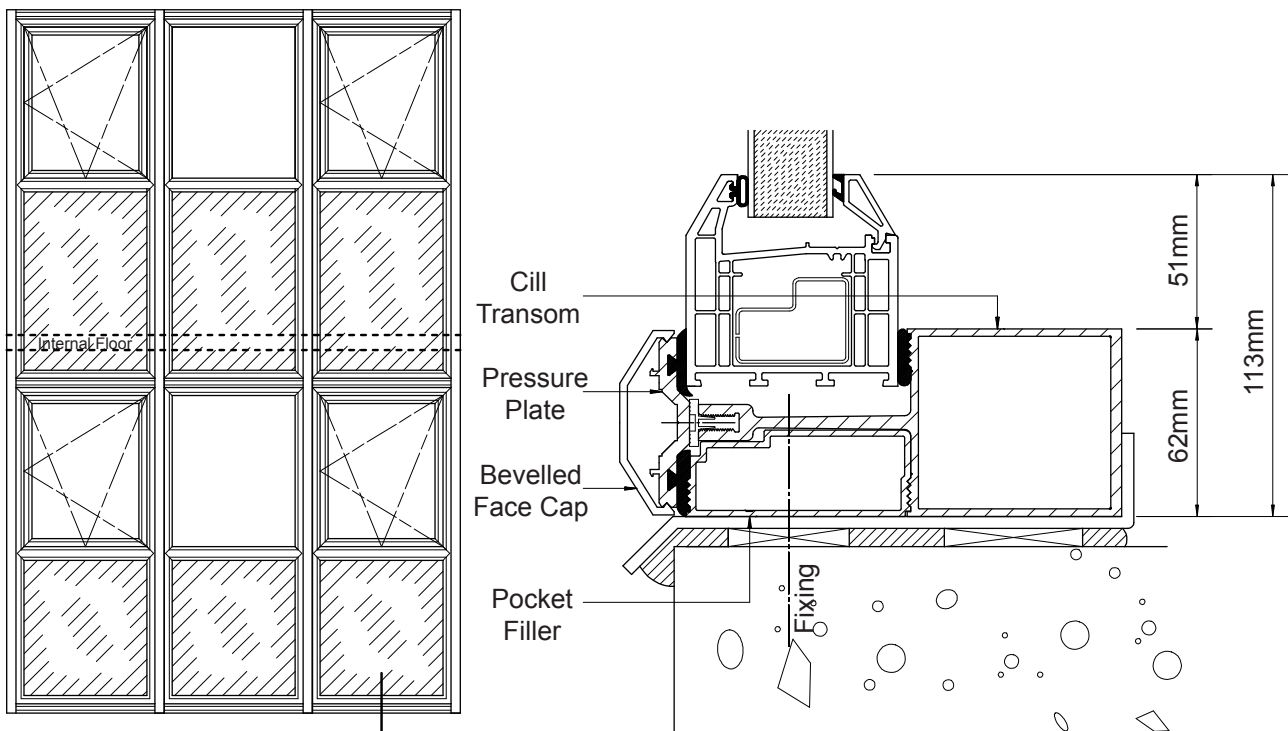

Note : SWR670/C used for illustration only. Frame packers may be required to ensure windows operate correctly.



CURTAIN WALLING - GENERAL ASSEMBLIES

JAMB FIXING - 70mm PROFILES

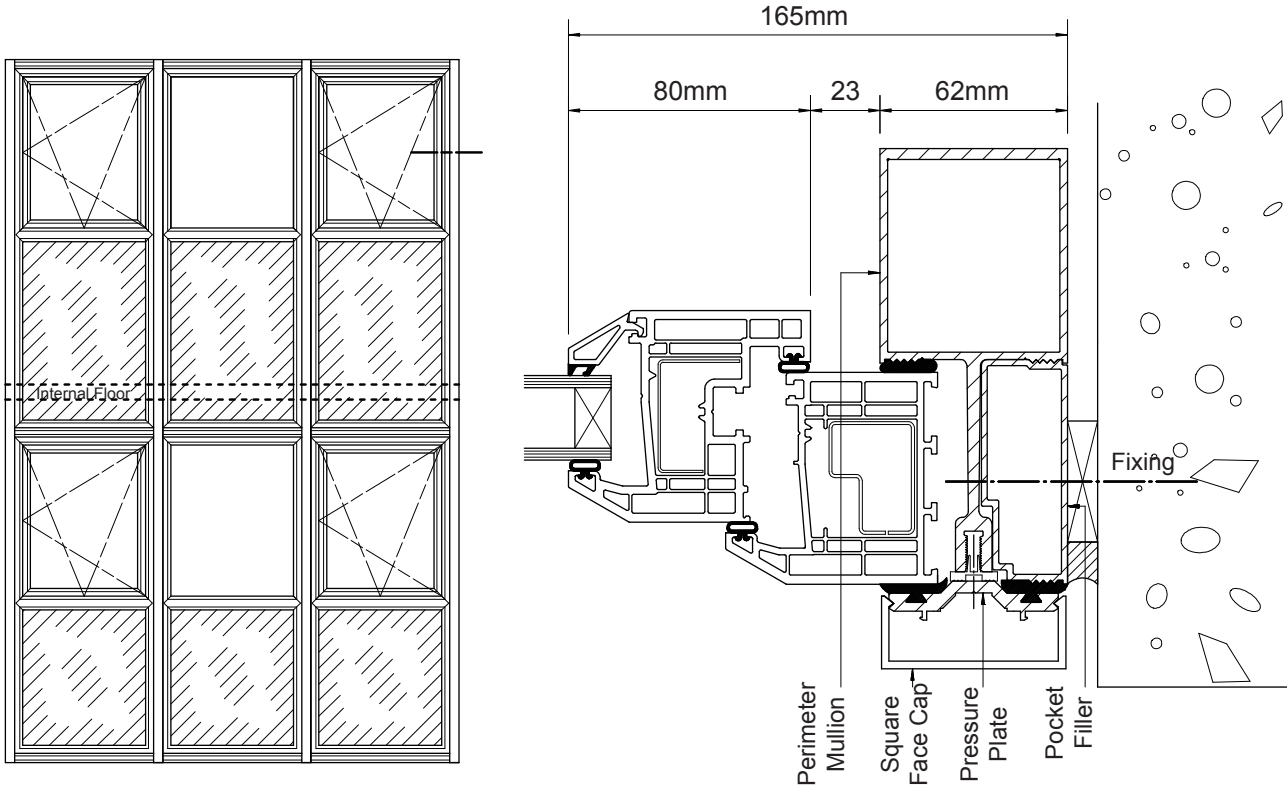

INTERMEDIATE MULLION - 70mm PROFILES

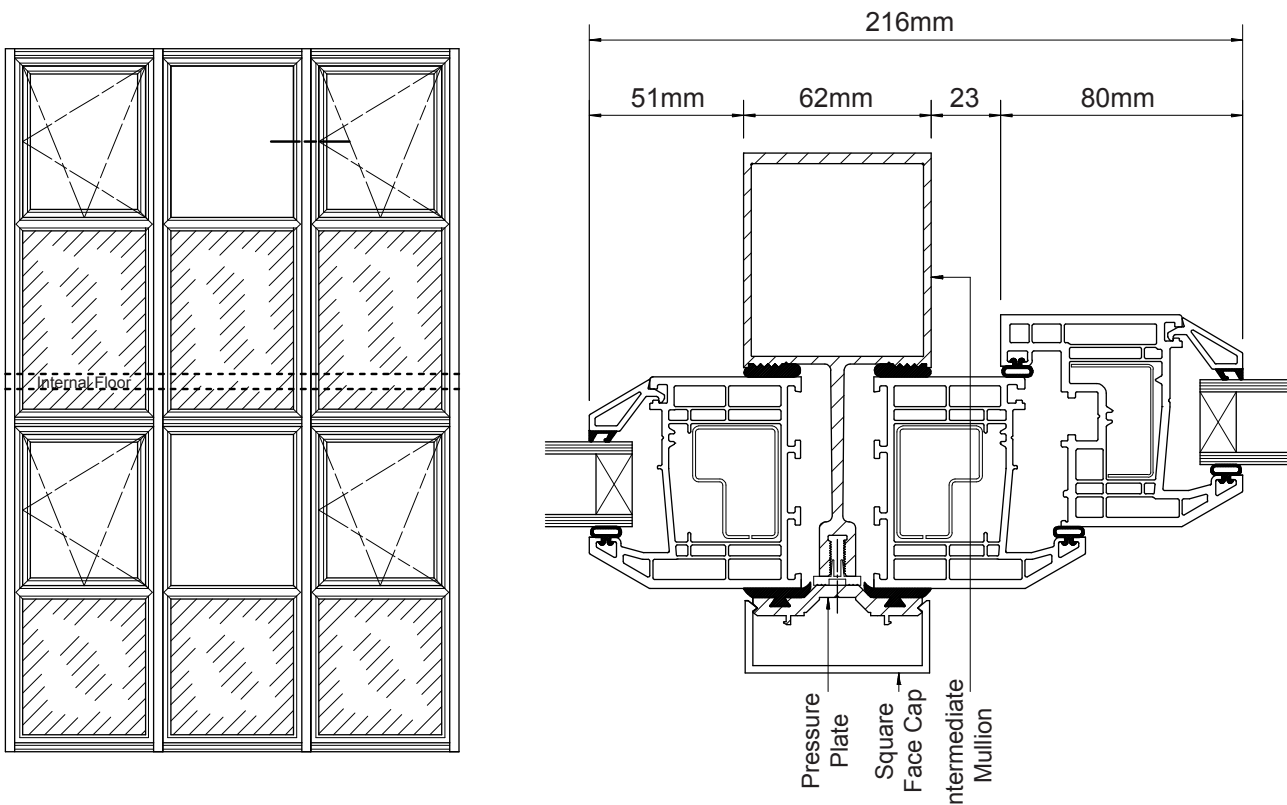

Note : SWR670/C used for illustration only. Frame packers may be required to ensure windows operate correctly.



CURTAIN WALLING - GENERAL ASSEMBLIES

TIE-BACK DETAIL - 70mm PROFILES

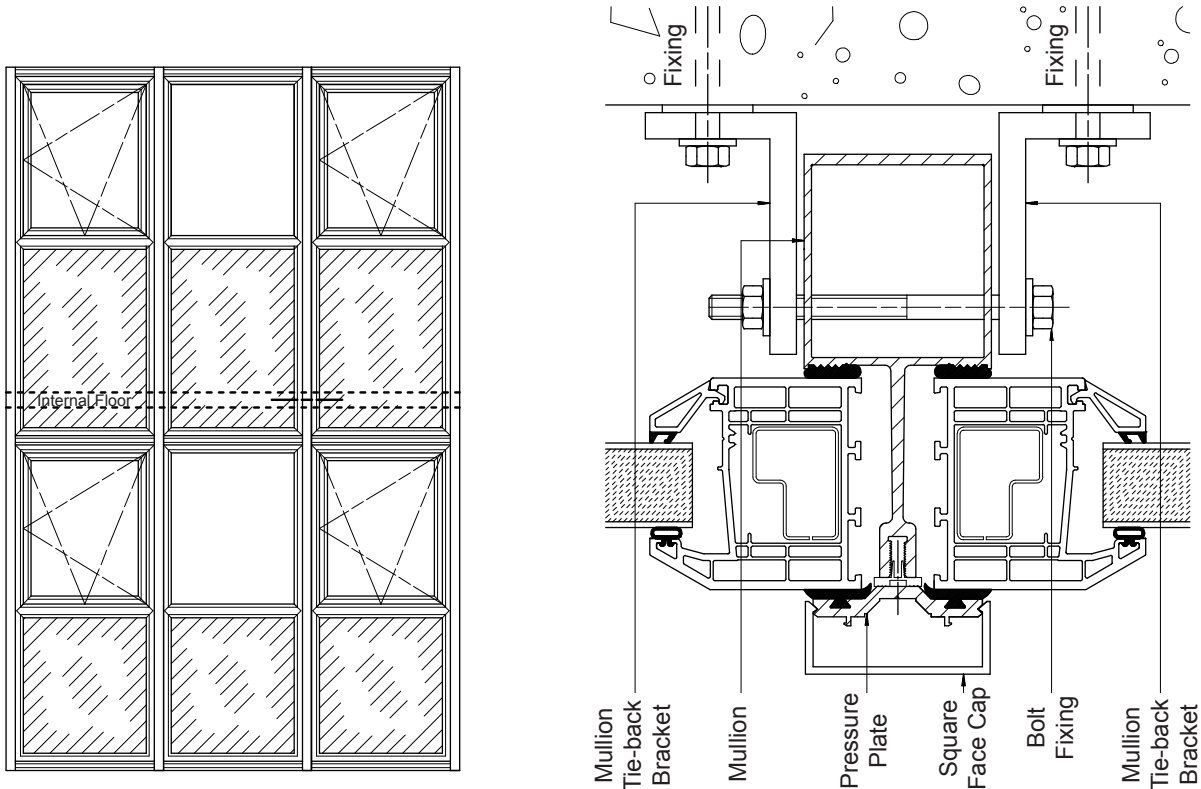

CORNER DETAILS - 70mm PROFILES

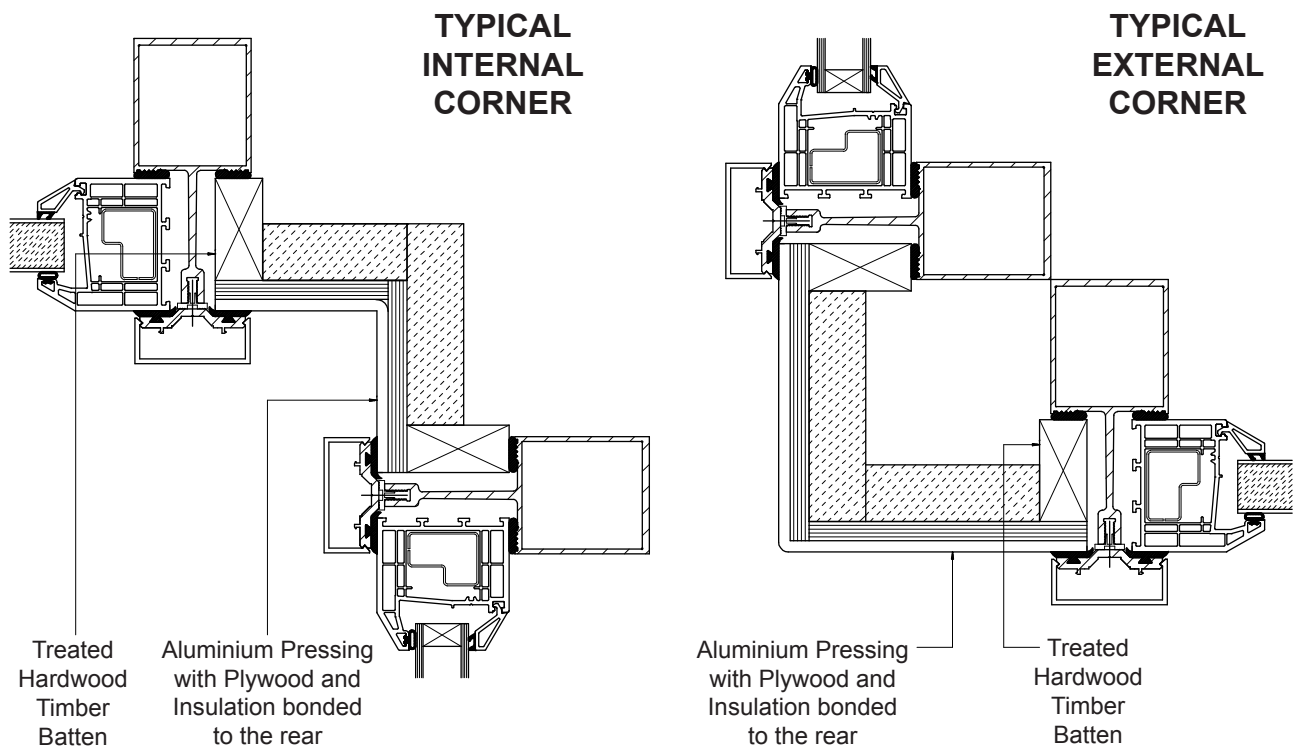

Note : SWR670/C used for illustration only. Frame packers may be required to ensure windows operate correctly.



CURTAIN WALLING - GENERAL ASSEMBLIES

HEAD FIXING - 63mm PROFILES

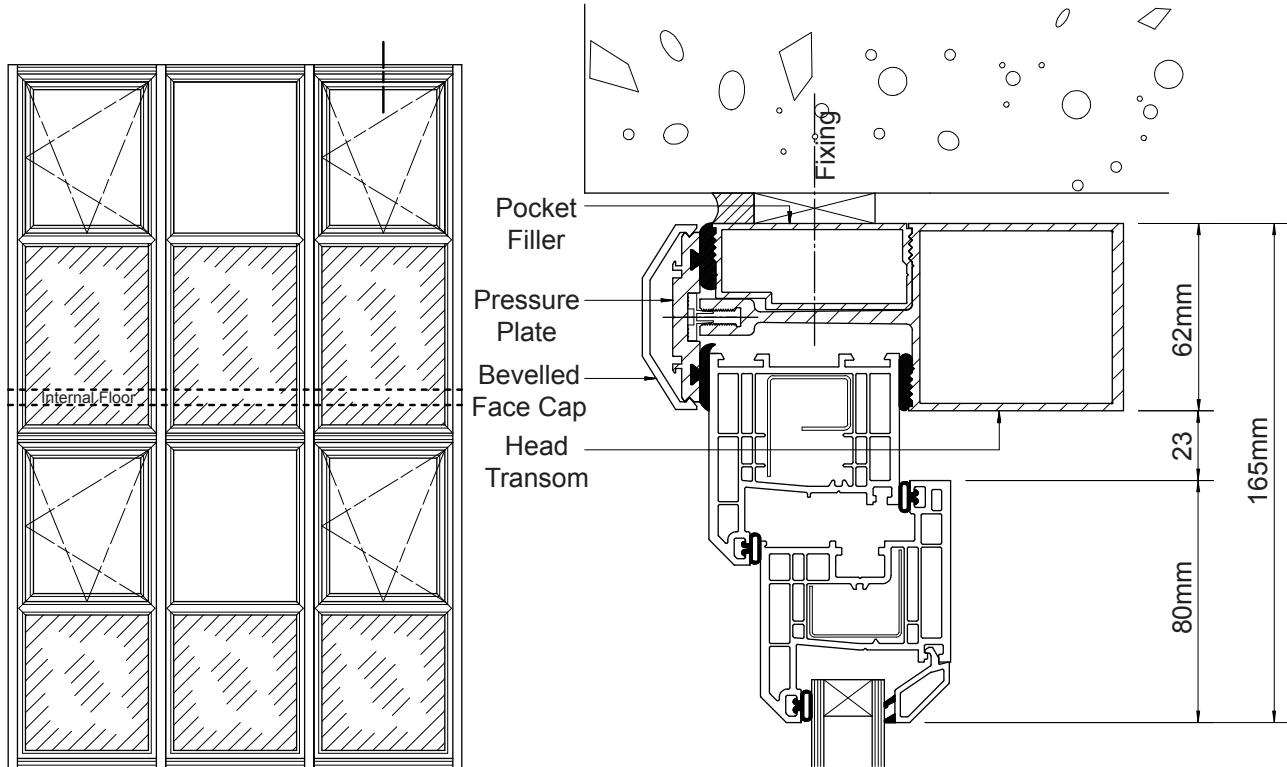

CILL FIXING - 63mm PROFILES

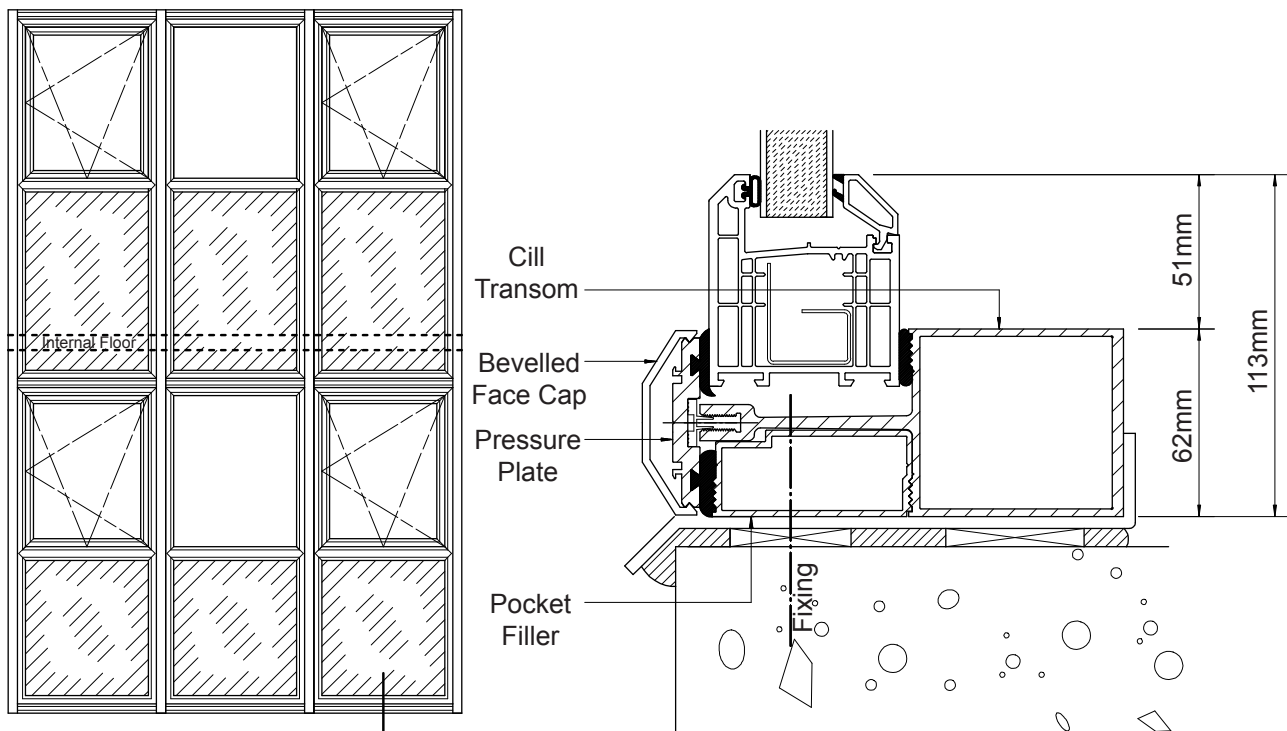

Note : SWR670/C used for illustration only. Frame packers may be required to ensure windows operate correctly.



CURTAIN WALLING - GENERAL ASSEMBLIES

JAMB FIXING - 63mm PROFILES

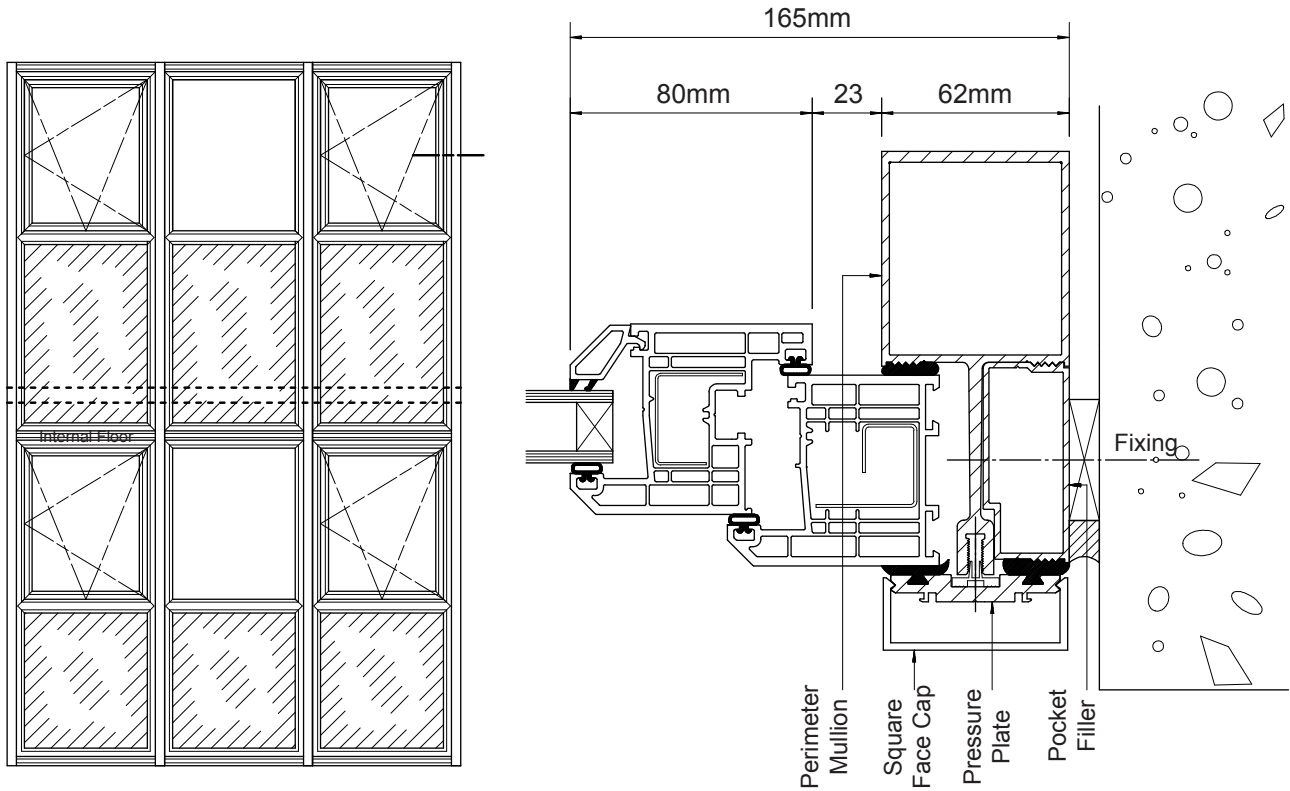

INTERMEDIATE MULLION - 63mm PROFILES

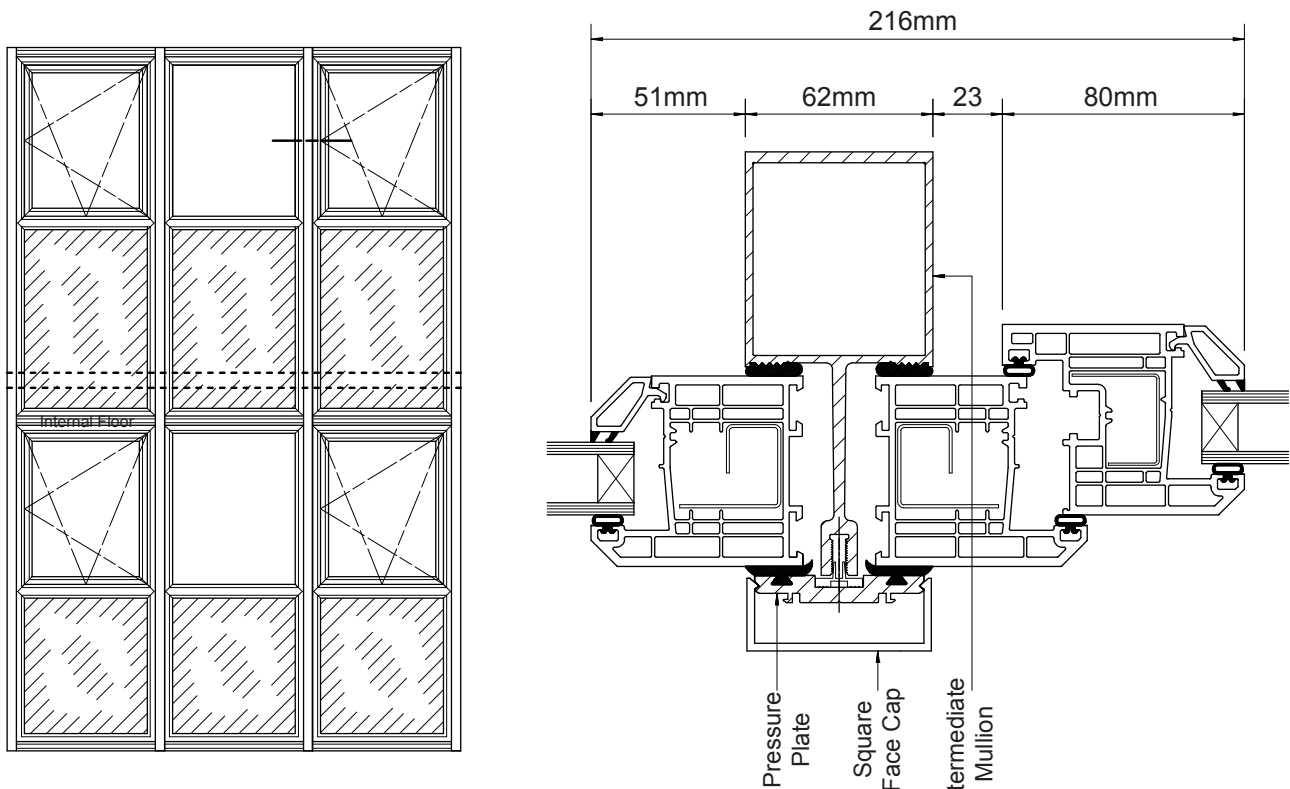

Note : SWR670/C used for illustration only. Frame packers may be required to ensure windows operate correctly.



CURTAIN WALLING - GENERAL ASSEMBLIES

TIE-BACK DETAIL - 63mm PROFILES

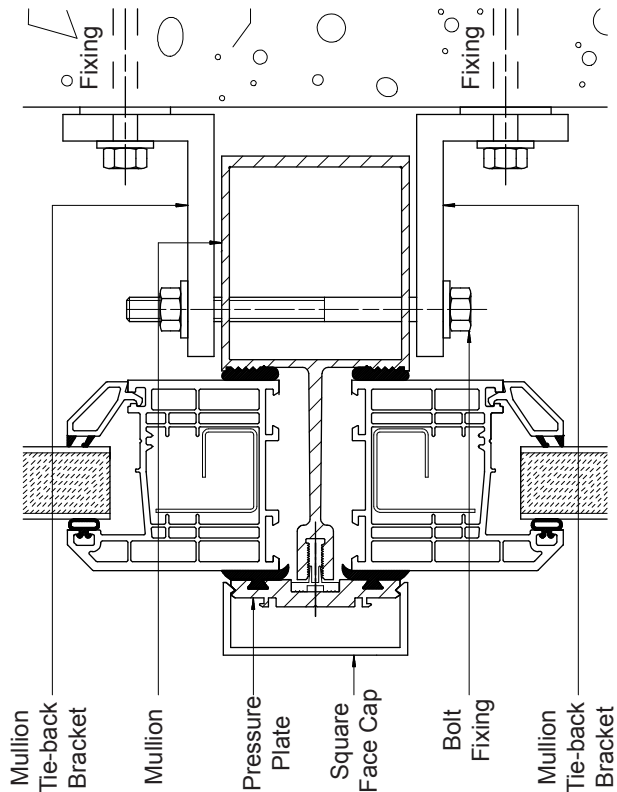
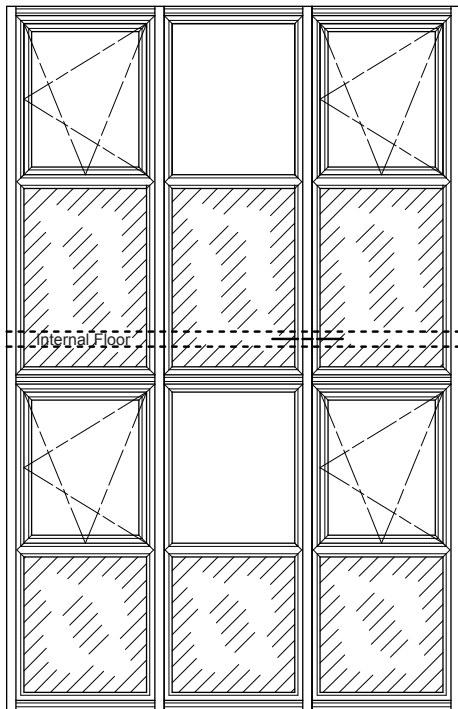

CORNER DETAILS - 63mm PROFILES

**TYPICAL
INTERNAL
CORNER**

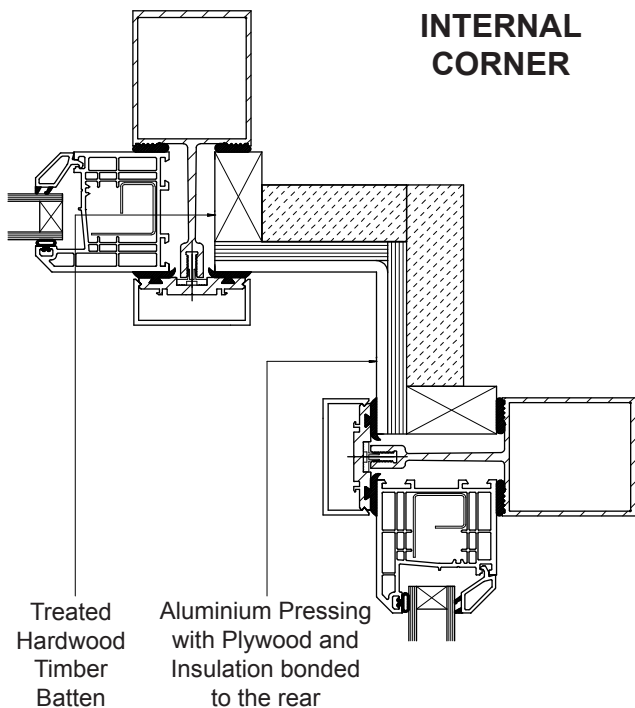

**TYPICAL
EXTERNAL
CORNER**

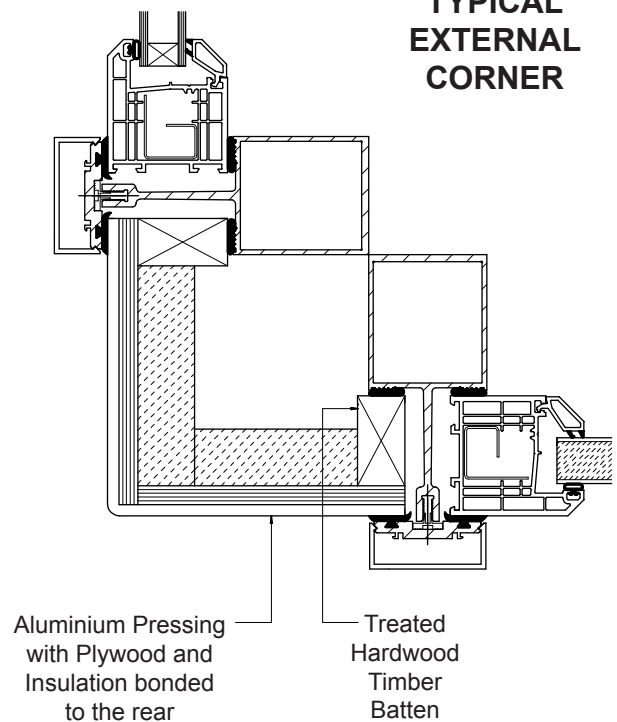

Note : SWR670/C used for illustration only. Frame packers may be required to ensure windows operate correctly.



GENERAL - PERFORMANCE

DESIGN DATA

Security

When built, fabricated and installed to the specifications laid down by Spectus Window Systems, Spectus windows can achieve the requirement of BS 7950, the standard for improved security and performance of domestic windows.

General testing

Internal and external testing of the finished product is carried out to the following standards:

- BS 6375 - performance of windows and doors:
Part 1: 2009 - Classification for weather tightness and guidance on selection and specification.
Part 2: 2009 - classification for operation and strength characteristics and guidance on selection and specification.

Structural/Mechanical strength and stability

As with all windows, products fabricated from Spectus profiles are generally not intended to be load bearing components of the building structure, except in the case of certain bay windows, where the provision of suitable reinforcement can make them so.

Reinforcement

Reinforcement in the form of galvanised steel or aluminium sections is incorporated within the profiles to enable strength requirements to be met.

Weather tightness

Spectus profiles are provided with weatherseals to give optimum performance with regard to weather tightness.

Weather testing / Air permeability

Spectus Window systems have been successfully weather-tested to BS 6375.

Thermal expansion

PVC-U window profiles have a co-efficient of thermal expansion of 1.0mm/m/20°C change in temperature.

Thermal transmittance (U Value)

The overall insulation performance of the window will depend on the effectiveness of the double glazed units. Specific guidance on thermal transmittance can be found in the appropriate section of current building regulations.

Biological

PVC-U is not affected by any of the common biological agents. It is totally inert with respect to biological action; it does not support the growth of mould or algae nor is it subject to attack by rot, wood worm or fungi. Regular cleaning of the PVC-U surface with a mild, non-abrasive detergent will prevent the build-up of any other substances which may support these biological agents.

Compatibility

PVC-U is compatible with all common building materials and no adverse reactions have been recorded.

Durability

PVC-U is exceptionally durable and product life is estimated to be in excess of 35 years. Installations in mainland Europe have been monitored over a 40-year period and show no degradation of the PVC-U. Durability is unaffected by coastal or saline environments, but can be affected by heavy industrial pollution.

Metal reinforcement

Where steel sections are used, they are isolated from the environment in specially sealed chambers to protect against corrosion in certain applications. Where it is not possible to isolate the reinforcement, then aluminium is used.

Hardware and fittings

Because of their exposure to the environment, these can suffer corrosion, particularly in coastal, saline or heavily polluted areas. Regular maintenance, cleaning and the application of light oil will maximise the life of exposed metal parts.



GENERAL - PERFORMANCE

WIND LOADING - CALCULATION METHOD

Scope

This calculation method deals with the maximum lengths of transoms & mullions in windows, according to the variables of :-

- Design Wind Pressure
- Load Span
- Load Width
- Transom/Mullion Selection

If the design wind pressure is not known it should be determined from current relevant standards.

Establishing Required Elyy Values

To establish the Elyy values required for window transoms and mullions, where E is the modulus of elasticity and Iyy is the moment of inertia about an axis perpendicular to the deflecting force. These are inherent properties of a profile and reinforcement combination.

Calculation Method

1. Get the Design Wind Pressure
2. Determine the load widths (A) and (B) as shown in the diagram below.
3. From the table on page Gen.5 the total Elyy value is derived and is read in the following method :-

Add together { set the load span against the load width (A) and read off the Elyy value
set the load span against the load width (B) and read off the Elyy value

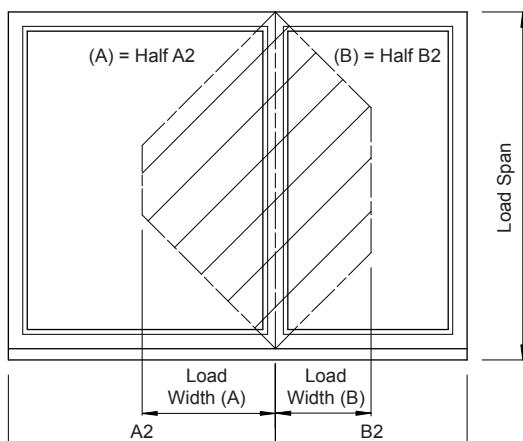

Example

Design Wind Pressure = 1200 Pa
Load width (A) = 500mm
Load width (B) = 400mm
Load Span = 1600mm

Required Elyy = Elyy(A) + Elyy(B)
Elyy = 4.08 + 3.47 = 7.55

The table on page Gen.3 is shown for 1200pa. If different pressure is required then this figure will need to be adjusted e.g. If pressure = 1600pa then :-

Elyy = Elyy x (1600/1200) = 10.07



GENERAL - PERFORMANCE

WIND LOADING - REQUIRED RIGIDITY

REQUIRED RIGIDITY EI_{yy} AT A DESIGN WIND PRESSURE OF 1200 Pa

Factors :-
($EI_{yy} \times 10^9 \text{ N.mm}^2$)
(Deflection = $L/150$)

	Load width (A) or (B) (mm)															1300	1350								
	150	200	250	300	350	400	450	500	550	600	650	700	750	800	850			900	950	1000	1050	1100	1150	1200	1250
600	0.07	0.08	0.09																						
700	0.11	0.14	0.16	0.18	0.18																				
800	0.17	0.22	0.25	0.28	0.30	0.31																			
900	0.25	0.32	0.38	0.43	0.46	0.48	0.49																		
1000	0.34	0.44	0.53	0.61	0.67	0.71	0.74	0.75																	
1100	0.45	0.59	0.72	0.83	1.92	1.00	1.05	1.09	1.10																
1200	0.59	0.77	0.94	1.10	1.23	1.34	1.44	1.50	1.54	1.56															
1300	0.76	0.99	1.21	1.42	1.60	1.76	1.89	2.00	2.08	2.13	2.14														
1400	0.95	1.24	1.53	1.79	2.03	2.25	2.44	2.59	2.75	2.81	2.86	2.88													
1500	1.17	1.54	1.89	2.22	2.53	2.81	3.07	3.28	3.47	3.61	3.71	3.78	3.80												
1600	1.42	1.87	2.31	2.72	3.11	3.47	3.79	4.08	4.33	4.54	4.70	4.82	4.89	4.92											
1700	1.71	2.25	2.78	3.28	3.76	4.21	4.62	4.99	5.32	5.60	5.84	6.02	6.16	6.24	6.26										
1800	2.03	2.68	3.31	3.92	4.50	5.04	5.55	6.02	6.44	6.81	7.13	7.39	7.60	7.75	7.84	7.87									
1900	2.39	3.16	3.91	4.63	5.33	5.98	6.60	7.17	7.70	8.17	8.58	8.94	9.24	9.47	9.64	9.74	9.77								
2000	2.79	3.69	4.57	5.42	6.24	7.03	7.77	8.46	9.10	9.69	10.21	10.68	11.08	11.41	11.66	11.85	11.96	12.00							
2100	3.23	4.28	5.30	6.30	7.26	8.19	9.06	9.89	10.66	11.38	12.03	12.61	13.13	13.57	13.93	14.22	14.42	14.54	14.59						
2200	3.72	4.93	6.11	7.27	8.38	9.46	10.49	11.47	12.39	13.24	14.04	14.75	15.40	15.96	16.45	16.85	17.16	17.39	17.52	17.57					
2300	4.25	5.63	6.99	8.32	9.61	10.86	12.06	13.20	14.28	15.30	16.24	17.11	17.90	18.61	19.23	19.76	20.20	20.54	20.79	20.94	20.99				
2400	4.83	6.41	7.96	9.48	10.96	12.39	13.77	15.09	16.35	17.54	18.66	19.70	20.65	21.52	22.29	22.97	23.55	24.03	24.40	24.67	24.83	24.88			
2500	5.46	7.25	9.01	10.73	12.42	14.05	15.64	17.16	18.61	19.99	21.30	22.52	23.65	24.69	25.64	26.48	27.22	27.85	28.37	28.77	29.06	29.24	29.30		
2600	6.15	8.16	10.15	12.10	14.00	15.86	17.66	19.40	21.06	22.66	24.17	25.59	26.92	28.15	29.28	30.31	31.22	32.02	32.70	33.27	33.70	34.02	34.21	34.27	
2700	6.89	9.15	11.38	13.57	15.72	17.81	19.85	21.82	23.72	25.54	27.27	28.91	30.46	31.90	33.24	34.47	35.57	36.56	37.43	38.16	38.77	39.24	39.59	39.79	39.86
2800	7.68	10.21	12.70	15.15	17.56	19.91	22.21	24.43	26.58	28.64	30.62	32.50	34.28	35.96	37.52	38.97	40.29	41.49	42.55	43.48	44.28	44.93	45.44	45.81	46.03
2900	8.54	11.35	14.12	16.68	19.54	22.17	24.74	27.24	29.66	31.99	34.23	36.37	38.41	40.33	42.14	43.82	45.38	46.80	48.09	49.24	50.24	51.09	51.79	52.34	52.73
3000	9.45	12.57	15.65	18.68	21.67	24.60	27.46	30.25	32.96	35.58	38.10	40.52	42.83	45.03	47.10	49.05	50.86	52.53	54.06	55.44	56.67	57.74	58.65	59.41	59.99

(mm) Load span



GENERAL - PERFORMANCE

WIND LOADING - SECTION PROPERTIES

Elyy Values

Transoms & Mullions

The Elyy values for each combined transom/mullion section are listed on pages Gen.5 to Gen.7 in this specifiers guide.

In the calculated example on page Gen.2, at 1200 Pa an Elyy value of 7.55 is required. Therefore, an intermediate 'T' transom with BR22S steel reinforcing (Elyy = 7.86) will be suitable.

In the same example, at 1600 Pa an Elyy value of 10.07 is required and the sections listed above would not be strong enough. Only a 'T' section midrail with BR24S (Elyy = 18.11) will be suitable.

Coupling Sections

The Elyy values for combined outer frame sections are listed on pages Gen.5 to Gen.7

The Elyy values for coupling mullion sections are listed on page Gen.10

The values for the outer frames can be added to the values of the coupling mullion to give a greater combined Elyy value.

Example (Elite 70)

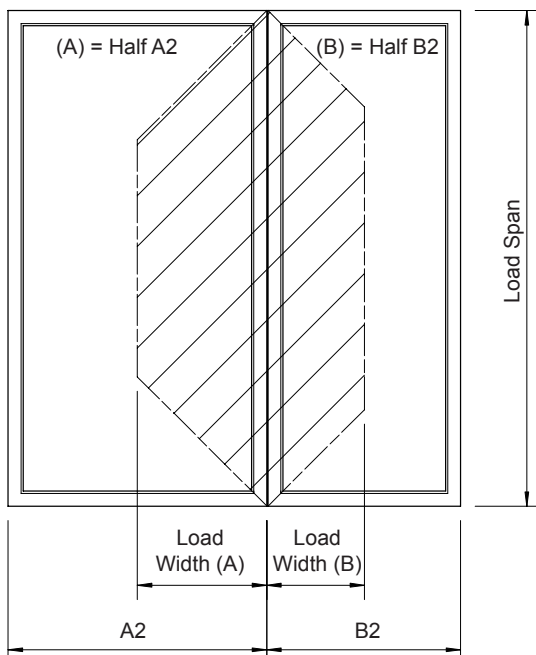

Design Wind Pressure = 1200 Pa
Load Width (A) = 500mm
Load Width (B) = 450mm
Load Span = 1700mm

$$\text{Required Elyy} = \text{Elyy (A)} + \text{Elyy (B)}$$

$$\text{Elyy} = 4.99 + 4.62 = 9.61$$

This value is too high for a standard mullion, therefore, the outer frame sections must be coupled. Using 2 Large Outer frames with BR07S steel reinforcing gives the value - Elyy = 11.94

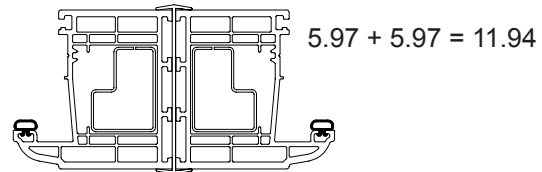

In this example, if the load span = 2400mm & the design wind pressure = 2000 Pa, then :-
Elyy = 15.09 + 13.77 = 28.86 x (2000/1200) = 48.10

This value is too high for 2 Large Outer frames with reinforcing so a coupling mullion, SWR748 (Elyy = 41.17) can be used to give the value - Elyy = 53.11

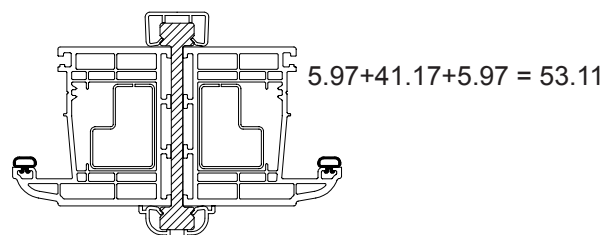

Note : Coupled sections must be screwed together at maximum 300mm centres.



GENERAL - PERFORMANCE

WIND LOADING - ELITE 70 PROFILES

The table below lists all the permutations for the combined Elyy values ($\times 10^9$ N.mm²) for Elite 70 profiles and reinforcements that can be considered for wind load calculations.

Profile Illustration	Profile Description	Reinforcing Elyy Value	Reinforcing Elyy Value	Reinforcing Elyy Value	Reinforcing Elyy Value
	BO1/BO5 Slim Outer	BR21 Aluminium Elyy = 2.27	BR20S Steel Elyy = 3.52	BR21S Steel Elyy = 5.26	
	B02/BO6 Intermediate Outer	BR06 Aluminium Elyy = 3.12	BR06S Steel Elyy = 4.47		
	B03/B07 Large Outer	BR07 Aluminium Elyy = 3.67	BR07S Steel Elyy = 5.97		
	B10/B20 Slim 'T' Transom	BR20 Aluminium Elyy = 2.04	BR21 Aluminium Elyy = 2.31	BR20S Steel Elyy = 3.56	BR21S Steel Elyy = 5.30
	B11/B21 Slim 'Z' Transom	BR21 Aluminium Elyy = 2.40	BR20S Steel Elyy = 3.65	BR21S Steel Elyy = 5.39	
	B14/B24 'T' Midrail	BR24 Aluminium Elyy = 6.22	BR24S Steel Elyy = 18.11		
	B15/B25 'Z' Midrail	BR24 Aluminium Elyy = 6.27	BR24S Steel Elyy = 18.16		
	B16 Bevelled Large 'T' Transom	BR16 Aluminium Elyy = 4.49	BR16S Steel Elyy = 6.31	BR17S Steel Elyy = 10.07	
	B17 Bevelled Large 'Z' Transom	BR16 Aluminium Elyy = 4.55	BR16S Steel Elyy = 6.37	BR17S Steel Elyy = 10.13	
	B22 Ovolo Intermediate 'T' Transom	BR06 Aluminium Elyy = 3.17	BR06S Steel Elyy = 4.52	BR22 Aluminium Elyy = 3.41	BR22S Steel Elyy = 7.86
	B23 Ovolo Intermediate 'Z' Transom	BR06 Aluminium Elyy = 3.25	BR06S Steel Elyy = 4.60	BR22S Steel Elyy = 7.94	

Note : Wind load properties are for combined sections, Elyy ($\times 10^9$ N.mm²)



GENERAL - PERFORMANCE

WIND LOADING - REVERSIBLE 70 PROFILES

The table below lists all the permutations for the combined Elyy values ($\times 10^9$ N.mm²) for Reversible 70 profiles and reinforcing that can be considered for wind load calculations.

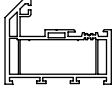
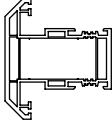
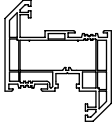
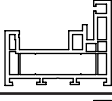
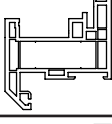
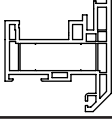
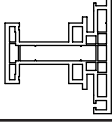
Profile Illustration	Profile Description	Reinforcing Elyy Value	Reinforcing Elyy Value	Reinforcing Elyy Value
	SW702 Glazed Outer	SWR702 Aluminium Elyy = 4.92	SWR702LS Steel Elyy = 7.72	SWR702S Steel Elyy = 10.61
	SW706 Glazed 'T' Transom	SWR706 Aluminium Elyy = 5.51	SWR716 Aluminium Elyy = 6.19	SWR706S Steel Elyy = 17.36
	SW707 Glazed 'Z' Transom	SWR707 Aluminium Elyy = 4.92	SWR707S Steel Elyy = 12.86	
	SW781 Reversible Outer Frame	SWR703 Aluminium Elyy = 3.98	SWR703LS Steel Elyy = 5.45	SWR703S Steel Elyy = 7.83
	SW782 Reversible/Glazed 'Z' Transom	SWR701 Aluminium Elyy = 4.83	SWR701LS Steel Elyy = 6.87	SWR704S Steel Elyy = 13.63
	SW783 Reversible/Glazed 'T' Transom	SWR701 Aluminium Elyy = 4.67	SWR701LS Steel Elyy = 6.71	SWR704S Steel Elyy = 13.47
	SW784 Reversible 'T' Double Mullion		SWR784S Steel Elyy = 9.16	

Note : Wind load properties are for combined sections, Elyy ($\times 10^9$ N.mm²)



GENERAL - PERFORMANCE

WIND LOADING - ELITE 63 PROFILES

The table below lists all the permutations for the combined Elyy values ($\times 10^9$ N.mm²) for Elite 63 profiles and reinforcements that can be considered for wind load calculations.

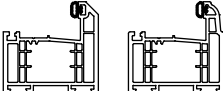
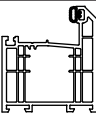
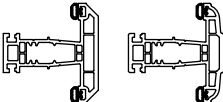
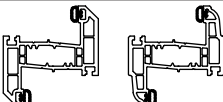
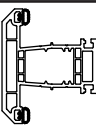
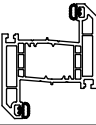
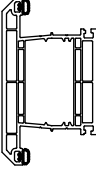
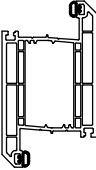
Profile Illustration	Profile Description	Reinforcing Elyy Value	Reinforcing Elyy Value	Reinforcing Elyy Value
	A01 Slim Outer	AR10S Steel Elyy = 2.00		
	A02/AO6 Intermediate Outer	AR02S Steel Elyy = 2.29		
	A03 Large Outer	AR03S Steel Elyy = 3.44		
	A10/A20 Slim 'T' Transom	AR10 Aluminium Elyy = 1.41	AR10S Steel Elyy = 2.05	AR11S Steel Elyy = 3.18
	A11/A21 Slim 'Z' Transom	AR10S Steel Elyy = 2.14	AR11S Steel Elyy = 3.27	
	A12 Intermediate 'T' Transom	AR12 Aluminium Elyy = 2.35	AR12S Steel Elyy = 2.95	AR13S Steel Elyy = 5.00
	A13 Intermediate 'Z' Transom	AR12 Aluminium Elyy = 2.43	AR12S Steel Elyy = 3.03	AR13S Steel Elyy = 5.00
	A14 'T' Midrail	AR14 Aluminium Elyy = 4.29	AR14S Steel Elyy = 9.98	
	A15 'Z' Midrail	AR14 Aluminium Elyy = 4.35	AR14S Steel Elyy = 10.04	

Note : Wind load properties are for combined sections, Elyy ($\times 10^9$ N.mm²)



GENERAL - PERFORMANCE

WIND LOADING - COUPLING PROFILES

The table below lists all the permutations for the combined Elyy values ($\times 10^9$ N.mm²) for 70mm coupling mullion and bay coupling profiles and reinforcing that can be considered for wind load calculations.

COUPLING MULLION PROFILES

Profile Illustration	Profile Description	Elyy Value
	SWM70 Aluminium Structural Mullion	57.87
	SWR748 Aluminium Coupling Mullion	41.17
	SWR748S Steel Coupling Mullion	62.81

BAY COUPLING PROFILES

Profile Illustration	Profile Description	Elyy Value
	CBP360 Aluminium Bay Pole	5.50
	BR70 Aluminium Bay Pole	2.97
	BR72 Aluminium Bay Pole	1.35
	BR73 Aluminium Bay Pole	0.85
	BR71 90° Aluminium Bay Post	12.90

The table below lists all the permutations for the combined Elyy values ($\times 10^9$ N.mm²) for 63mm coupling mullion and bay coupling profiles and reinforcing that can be considered for wind load calculations.

COUPLING MULLION PROFILES

Profile Illustration	Profile Description	Elyy Value
	AR93 Aluminium Structural Mullion	45.80
	AR85 Aluminium Coupling Mullion	32.36
	AR85S Steel Coupling Mullion	49.81

BAY COUPLING PROFILES

Profile Illustration	Profile Description	Elyy Value
	CBP360 Aluminium Bay Pole	5.50
	BR70 Aluminium Bay Pole	2.97
	BR72 Aluminium Bay Pole	1.18
	BR71 90° Aluminium Bay Post	12.53

Note : Wind load properties are for combined sections, Elyy ($\times 10^9$ N.mm²)



GENERAL - PERFORMANCE

LOAD BEARING BAYPOLES

Load Bearing Bays

For **all** load bearing bay window installations, the advice of a structural engineer **must** be sought.

Bay Jacking Assemblies (BB75), comprising of jacking bases and jacking plates, are required for **all** load bearing poles (see below)

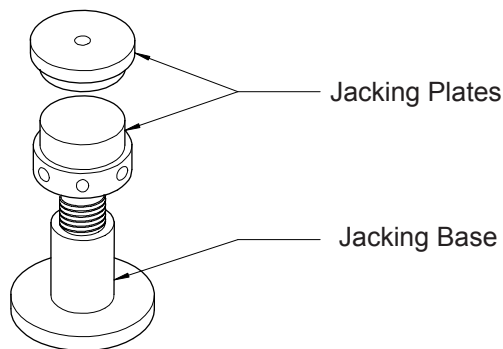

The jacking base fits at the bottom of the assembly underneath the cill to anchor the bay pole and spread any load acting on it. The top and bottom jacking plates fit to either end of the bay pole. The jacking cam is then turned to push the bay pole upwards until it is in a secure load bearing position. The detail below shows the jacking base and jacking plates in situ with the CBP360 bay pole on the Elite 70 window system.

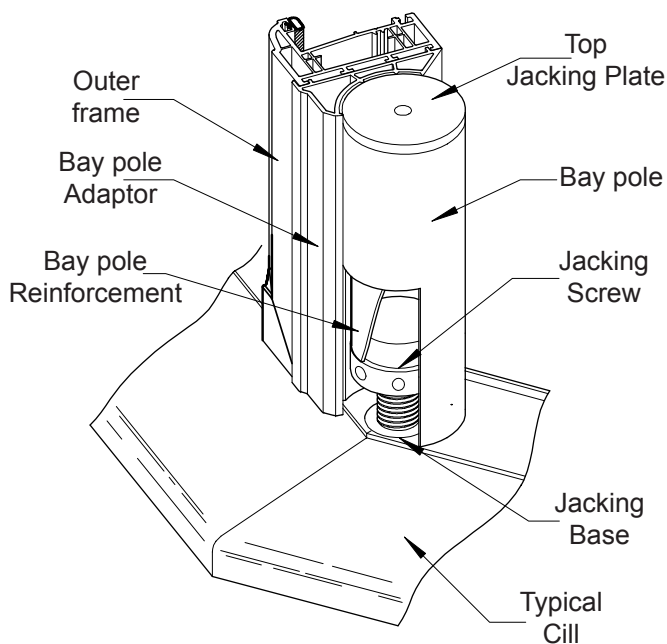

Load Bearing Data

The table below gives a guide to the **maximum** load each bay pole reinforcement **CBP360** will withstand

Effective bay pole length	Maximum Load
700mm	2.82 tonnes
800mm	2.70 tonnes
900mm	2.54 tonnes
1000mm	2.38 tonnes
1100mm	2.22 tonnes
1200mm	2.00 tonnes
1300mm	1.70 tonnes
1400mm	1.40 tonnes
1500mm	1.30 tonnes
1600mm	1.13 tonnes

Note :- If the bay pole reinforcement is restrained at the centre, for example by means of the adjacent windows, then the effective length is only 70% of the actual length of the bay pole reinforcement.

Example:-

If CBP360 actual length is 1286mm and **not restrained** the maximum load is 1.70 tonnes.

If CBP360 actual length is 1286mm and **is restrained** then $1286\text{mm} \times 70\% = 900\text{mm}$ effective length. Therefore the maximum load is 2.54 tonnes.

Note : For all load bearing bay window installations the advice of a structural engineer must be sought.



GENERAL - PERFORMANCE

THERMAL - WHOLE WINDOW U VALUES & CO₂ EMISSIONS

In Oct. 2010, Approved Document L of the building regulations for England and Wales changed. The new regulations allow for different methods of proving compliance. This depends upon whether the building is a dwelling or not, and whether the building is new or existing.

The four methods of compliance are :-

- Whole Window U Value
- CO₂ emissions
- Window Energy Rating (WER)
- Glass centre pane U value

• Whole Window U Values

The thermal transmission of the whole window can be derived using the simplified calculation method in BS EN 10077.1 2006 as shown below:-

$$U_w = \frac{A_g \cdot U_g + A_f \cdot U_f + l_g \cdot \Psi_g}{A_g + A_f}$$

Example: Elite 70
(Intermediate Outer Frame, Soft Coat & Argon)

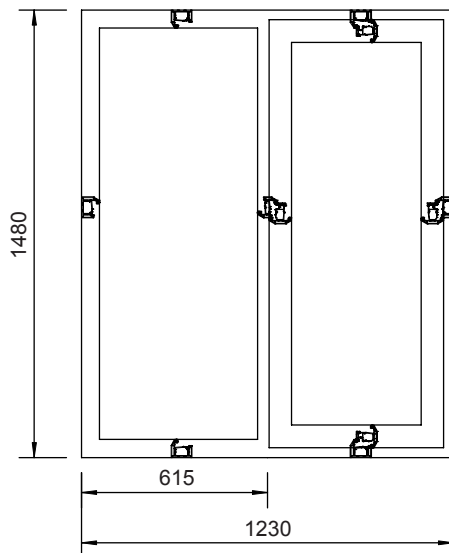

Where :-

$A_g = 1.252$ (area of glass)

$U_g = 1.2$ (thermal transmittance of glass)

$A_f = 0.568$ (area of frame)

$U_f = 1.440$ (thermal transmittance of frame)

$l_g = 7.151$ (Total perimeter of glazing)

$\Psi_g = 0.06$ (linear thermal transmittance of frame/
glazing junction)

$$U_w = 1.5 \text{ W}/(\text{m}^2\text{K})$$

The simplified method is generally used to provide U-value calculations for specific windows.

Whole window U-values are affected by:-

Size and configuration of window

The example shown uses the standard window size and configuration (1230mm x 1480mm sash next to fixed). This is from Annex E of BS EN 14351-1. Different windows will produce a different whole window U-value.

U_g - Thermal transmittance of glass

The example shown uses a thermal transmittance of glass (U_g) of 1.2. This figure varies according to the make-up of the double glazed unit (glass type, argon fill, etc) This information should be available from glass suppliers.

U_f - Thermal transmittance of frame

The example shown uses a thermal transmittance of frame (U_f) of 1.440. This figure is typical for the Elite 70 window system and has been extrapolated from testing carried out at the National Physics Laboratory.

Ψ_g - Thermal transmittance of frame/glazing

The example shown uses a linear thermal transmittance of frame/glazing junction (Ψ_g) of 0.06. This is a typical figure for an aluminium spacer bar. Using warm edge spacers will produce a different figure.

• CO₂ emissions

These will be calculated for the whole building by the architect/engineer. The CO₂ emissions calculation methods are :-

- Target CO₂ Emissions Rating (TER)
- Standard Assessment Procedure (SAP)
- Standard Buildings Emission Method (SBEM)

Target CO₂ Emissions Rating (TER)

This only applies to new dwellings and the maximum U-value allowed is 2.0 for windows & doors.

Standard Assessment Procedure (SAP)

This is the governments standard assessment procedure for energy rating of dwellings.

Standard Buildings Emission Method (SBEM)

This only applies to non-dwellings and for most projects a U-value of 2.0 will be assumed for windows.



GENERAL - PERFORMANCE

THERMAL - WINDOW ENERGY RATING (WER)

• **Window Energy Rating (WER)**

Windows lose heat through the various parts of the window and through a range of heat transfer methods. Window energy rating is a method of assessing the complete window and producing a single number to rate the energy efficiency of a specific type of window.

Windows are rated by three types of energy flow:

- Solar gain (g-value) - Positive
- Thermal Transmittance (U-value) - Negative
- Air Leakage (L-value) - Negative

Each type of energy flow has an affect on the overall energy efficiency of the product.

Solar gain (g-value)

Solar energy is reflected, absorbed and transmitted through the glass. The solar gain (g-value) measures the amount of solar energy gained by the inside as a percentage of the solar energy from outside. E.g. If the solar radiation outside is taken as 100%, and the solar radiation inside measures 40%, then $g = 0.40$

Thermal transmittance (U-value)

The U-value measures the amount of thermal transmittance lost through the window through convection, conduction and radiation. Lower U-values are better than higher U-values. E.g. Typical single glazing gives a U-value of $6.0 \text{ W}/(\text{m}^2\text{K})$, whereas typical double glazing with a low-E coating gives a U-value of $1.2 \text{ W}/(\text{m}^2\text{K})$.

Air Leakage (L-value)

The L-value measures the warm air loss from inside to outside. This occurs at the joint between the opening sashes and frame members and the joint between the frame/bead and the glass.

WER Modelling Process

Specific window cross-section drawings are imported into modelling software along with the known thermal conductivity of each element within the drawing. The software then calculates the WER and can also generate graphical representations of temperature gradients of the cross-section drawing.

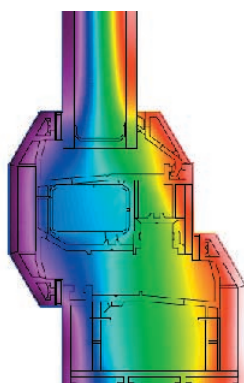

British Fenestration Rating Council (BFRC)

The British Fenestration Rating Council (BFRC) is an independent body that controls energy rating of windows in the UK.

BFRC Labelling

Windows can now carry energy ratings or labels, similar to those already seen on household appliances such as refridgerators and washing machines. Windows are rated using a familiar A to G scale on the basis of their total energy efficiency, where an A-rated window is more energy efficient than a G-rated window. When windows have the same letter, the Energy Index ($\text{kWh}/\text{m}^2/\text{year}$) can be used for comparison. This gives details of the energy consumption or gain for the sample window.

Energy Window	
Energy Windows Ltd. XYZ 68/abc	
	C
Energy Index ($\text{kWh}/\text{m}^2/\text{year}$) <small>(Energy Index certified by BFRC and based on UK standard window. The actual energy consumption for a specific application will depend on the building, the local climate and the indoor temperature)</small>	-15
The climate zone is:	UK
Thermal Transmittance (U_{window})	1.5 $\text{W}/\text{m}^2\text{K}$
Solar Factor (g_{window})	0.41 $\text{W}/\text{m}^2\text{K}$
Effective Air Leakage (L_{factor})	0.02 $\text{W}/\text{m}^2\text{K}$
	Reg. No.: XXX www.bfrc.org
<small>This label is not a statutory requirement. It is a voluntary label provided as a customer service to allow consumers to make informed decisions on the energy performance of competing products.</small>	

Note : Example label only



GENERAL - PERFORMANCE

THERMAL - DOOR ENERGY RATING (DER)

• Door Energy Rating (DER)

In September 2011 the BFRC extended the current Window Energy Rating scheme to cover doorsets of various types.

Doorsets are rated by three types of energy flow:

- Solar gain (g-value) - Positive
- Thermal Transmittance (U-value) - Negative
- Air Leakage (L-value) - Negative

Each type of energy flow has an effect on the overall energy efficiency of the product.

Unlike the Window Energy Rating scheme, doors are split into different classifications for the purpose of rating them. This is due to the different requirements with regard to the inclusion of solar gain as part of the rating equation.

Classifications

1. External Pedestrian Doorsets:

These are basic entrance/exit doors. There are three categories dependant on glass area. No solar gain is applicable to this door type and so the formula & band cut-offs, for calculating the Energy Rating, are different to that for windows.

2. Sliding Patio & French Doorsets:

Both of these types of doorset will include solar gain and will use the Window Energy Rating formula and band cut-offs to calculate the Energy Rating.

3. Sliding Folding (Bi-Fold) Doorsets:

This type of doorset will include solar gain and will use the Window Energy Rating formula and band cut-offs to calculate the Energy Rating.

THERMAL - SPECTUS TYPICAL RESULTS

TRIPLE GLAZING (44mm)

Window System	Outer Frame	Spacer Bar	Outer pane glass type	Cavity fill	Inner panes glass type	Whole window U-value	Energy Rating	Energy Index	Glass centre pane value
Elite 70	Slim	Warmedge	4mm Float	90% Argon	4mm Softcoat ($E_m 0.01$)	0.8 W/m ² K	N/A	N/A	0.5 W/m ² K
Elite 70	Slim	Warmedge	4mm Low iron	90% Argon	4mm Hardcoat ($E_m 0.05$)	0.9 W/m ² K	A	22	0.6 W/m ² K
Elite 70	Intermediate	Warmedge	4mm Low iron	90% Argon	4mm Hardcoat ($E_m 0.05$)	1.0 W/m ² K	A	20	0.6 W/m ² K
Elite 70	Intermediate	Aluminium	4mm Float	Air	4mm Hardcoat	1.5 W/m ² K	C	-16	1.0 W/m ² K

DOUBLE GLAZING (28mm)

Window System	Outer Frame	Spacer Bar	Outer pane glass type	Cavity fill	Inner pane glass type	Whole window U-value	Energy Rating	Energy Index	Glass centre pane value
Elite 70	Slim	Warmedge	4mm Low iron	20mm 90% Argon	4mm Softcoat	1.4 W/m ² K	A	5	1.2 W/m ² K
Elite 70	Slim	Warmedge	4mm Low iron	20mm 90% Argon	4mm Hardcoat	1.6 W/m ² K	B	-2	1.5 W/m ² K
Elite 70	Intermediate	Warmedge	4mm Low iron	20mm 90% Argon	4mm Softcoat	1.4 W/m ² K	A	3	1.2 W/m ² K
Elite 70	Intermediate	Warmedge	4mm Low iron	20mm 90% Argon	4mm Hardcoat	1.6 W/m ² K	B	-4	1.5 W/m ² K
Elite 70	Intermediate	Aluminium	4mm Float	20mm 90% Argon	4mm Softcoat	1.6 W/m ² K	C	-15	1.2 W/m ² K

DOUBLE GLAZING (24mm)

Window System	Bottom Rail	Spacer Bar	Outer pane glass type	Cavity fill	Inner pane glass type	Whole window U-value	Energy Rating	Energy Index	Glass centre pane value
V/Slider	Standard	Warmedge	4mm Low iron	16mm 90% Argon	4mm Softcoat	1.4 W/m ² K	A	11	1.2 W/m ² K
V/Slider	Standard	Warmedge	4mm float	16mm 90% Argon	4mm Softcoat	1.4 W/m ² K	A	6	1.2 W/m ² K
V/Slider	Standard	Warmedge	4mm float	16mm 90% Argon	4mm Hardcoat	1.6 W/m ² K	A	8	1.5 W/m ² K

The information provided above is for guidance only. Due to the changeable nature of both procedure and product specifications, confirmation should be sought from Spectus Window Systems prior to its use.

Whole window U values shown are in accordance with the BFRC WER calculation method.

Elite 63 results are usually the same as for Elite 70. Confirmation should be sought from Spectus Window Systems prior to use.



GENERAL PERFORMANCE

SOUND INSULATION

Overview

Sound insulation for building interiors against external noise has now become a major design consideration, due to the rapid increase in road and air traffic and industrial activity. Sources of noise can cause inconvenience, annoyance, stress and even diagnosable illness.

The loudness of sounds is measured in decibels (dB). The table below shows typical dB levels for general locations and activities.

dB Level	Location / Activity
140	Rock music peak
130	Air raid siren, shotgun
120	Thunderclap, Rock concert
110	Pneumatic drill, power saw
100	Jet takeoff @ 500m, train horn @ 30m
90	Loud shout, lawnmower,
80	Busy traffic intersection,
70	Vacuum cleaner, roadside traffic
60	Noisy office, light traffic @ 15m
50	Quiet office, normal conversation
40	Stream, refrigerator humming
30	Soft music, public library
20	Rustling leaves, Insects
10	Soft whisper, normal breathing
0	Threshold of hearing

0 - 90dB - Noises up to 80dB can be considered annoying and intrusive.

90 - 100dB - Prolonged exposure to noises above 90 dB can cause gradual hearing loss.

Over 100dB - Regular exposure of more than 1 minute risks permanent hearing loss.

Testing

Laboratory tests have been carried out on windows manufactured using Spectus window systems profiles and various glass types and thickness.

Sound insulation tests have been carried out on Spectus Elite 70 windows (to BS EN ISO 140 Part 3 1995). The samples tested were 1000mm x 1000mm fixed light windows.

These tests achieved a weighted sound reduction index value (R_w) of 40dB and 38dB (see below).

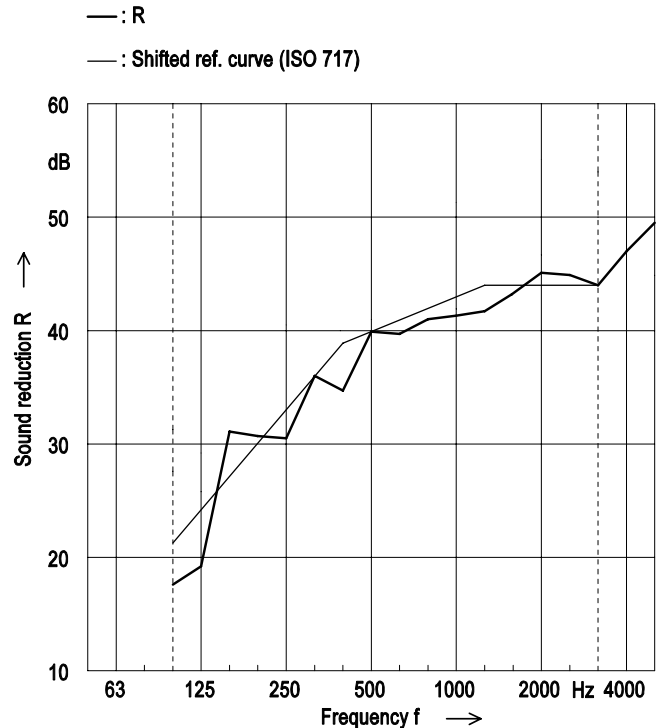

Elite 70 Casement

Glass specification 10 Planibel/20/44.2 Stratophone (38mm)
 $R_w = 40\text{dB}$

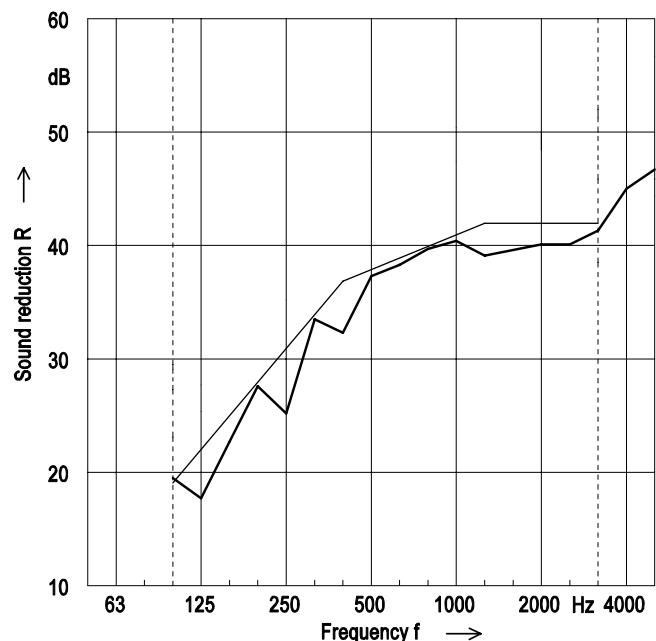

Elite 70 Casement

Glass specification 10/12/6.4 Laminated (28mm)
 $R_w = 38\text{dB}$

Note : For more information on sound insulation, please contact our commercial department.



GENERAL - PERFORMANCE

SOUND INSULATION

The results of sound insulation tests carried out on Spectus windows (to BS EN ISO 140 Part 3 1995) are shown below. The samples tested were 1200mm x 1200mm top hung opening sashes.

Rw is the weighted sound reduction index value calculated in accordance with BS EN ISO 717-1 1997.

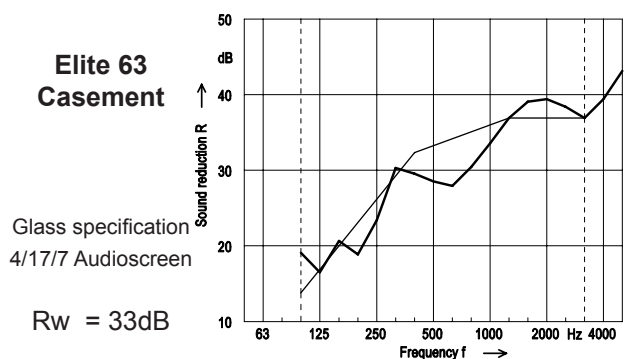
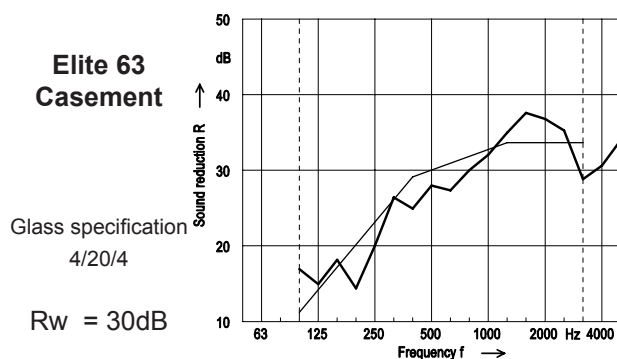
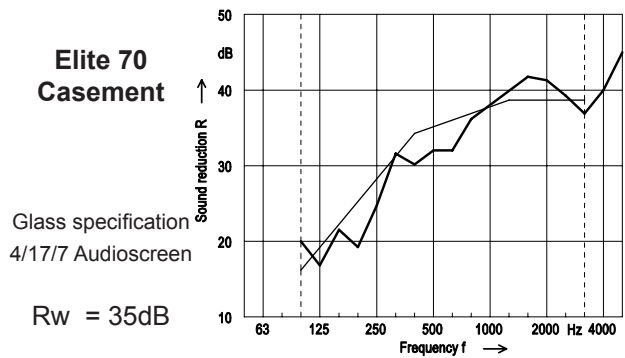
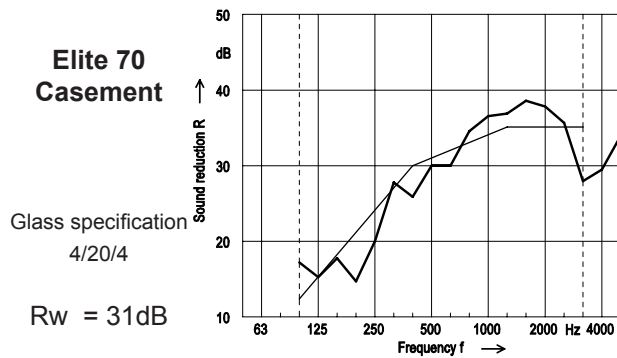
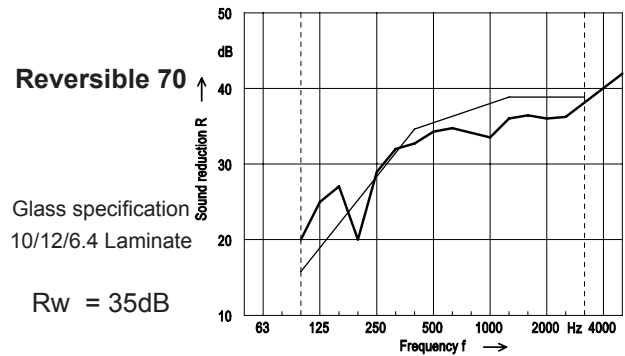
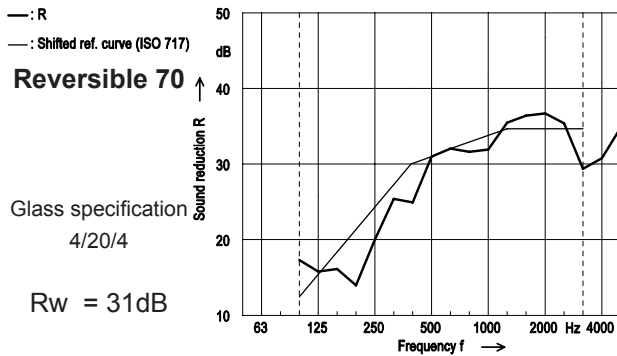

Note : For more information on sound insulation, please contact our commercial department.



GENERAL PERFORMANCE

BUILDING REGULATIONS

Approved Documents and Building Regulations publications.

Practical guidance on ways to comply with the functional requirements in the Building Regulations is outlined in a series of 'Approved Documents' published by the Department for Communities and Local Government.

Each Document contains:

- general guidance on the performance expected of materials and building work in order to comply with each of the requirements of the building regulations; and
- practical examples and solutions on how to achieve compliance for some of the more common building situations.

All of the latest 'Approved Documents' can be downloaded free on the Planning Portal at:

www.planningportal.gov.uk/approveddocuments

Due to the rate of change of the requirements of the Building Regulations it is recommended that the current version is referred to in all instances.

Relevant Approved Documents

Part B (Fire Safety)

This section covers the technical guidance contained in Part B of schedule 1 of the Building Regulations concerned with the requirements with respect to fire safety.

The main area of interest with regard to windows and doors is ensuring that there are a sufficient number of adequate escape routes suitably located to enable persons to escape to a place of safety in the event of a fire.

Part F (Ventilation)

This section covers the technical guidance contained in Part F of schedule 1 of the Building Regulations concerned with the requirements with respect to Ventilation.

Part L (Conservation of fuel and power)

This section covers the technical guidance contained in Part L of schedule 1 of the Building Regulations concerned with the requirements with respect to Conservation of fuel and power.

Approved Document is split into four parts:

Approved Document L1A:
This covers New Dwellings.

Approved Document L1B:
This covers Existing Dwellings.

Approved Document L2A:
This covers New Buildings other than Dwellings.

Approved Document L2B:
This covers Existing Buildings other than Dwellings.

The main area of interest with regard to windows and doors is the performance with regard to thermal transmittance (U value) and/or Energy Rating. The actual performance criteria required will depend on the building type and the calculation method being used.

Part M (Access to and Use of Buildings)

This section covers the technical guidance contained in Part M of schedule 1 of the Building Regulations concerned with the requirements with respect to Access to and use of buildings.

Part N (Glazing Safety)

This section covers the technical guidance contained in Part N of schedule 1 of the Building Regulations concerned with the requirements with respect to Glazing safety.

Compliance

All Spectus Window Systems products are able to meet the relevant requirements of the Building Regulations.



GENERAL - INSTALLATION

PREPARATION

The following section is designed to give guidance on the installation & maintenance of Spectus PVC-U windows & doors.

The procedures in BS 8213-4, Code of practice for the survey and installation of windows and external doorsets (or any subsequent updates), should be followed.

Pre-Start Check

Check the survey and goods

Prior to starting any work the installer should check the following :-

- The survey sheets are correct and clear
- The types of windows supplied are correct to the **customers order** and are **undamaged**.
- **Glass** type and pattern are correct.
- **Window** and **glass sizes** are compatible.
- All cills, trims and gaskets are correct.

Care of property

The **installer is responsible** for both internal and external protection.

Check for both internal and external defects in the structure. Any found should be checked with the surveyor.

Any furniture and fittings should be moved away from the working area.

Carpets and soft furnishings should be covered with clean dust sheets.

All access areas should be covered with dust sheets.

Check the windows are **not load-bearing**. Ensure there is a lintel or suitable load-transferring structure above the window.

Removal of existing windows

Flat windows

Damage will inevitably be caused to the adjacent reveals but care must be taken to keep this to a minimum.

Score around the internal perimeter to minimise damage to plaster and decorations.

Remove any trims and cover fillets.

Remove all opening lights.

Remove fixed light glass carefully to avoid injury.

Cut through and remove transoms and mullions.

Saw through the jambs and remove them taking care not to damage internal cills. Remove heads and cills in the same way.

If a new internal cill is to be fitted, remove the existing cill at the same time.

Load-bearing bays

If a replacement bay window is load-bearing, the advice of a structural engineer must be sought prior to the removal of the existing window assembly.

The spectus load bearing bay assembly may be used.

Bay windows

When removing bay windows **temporary supports will be required** e.g. Acrow Props or similar. Care must be taken on the position of the props which should support the superstructure without causing damage. Internal and external supports may be necessary.

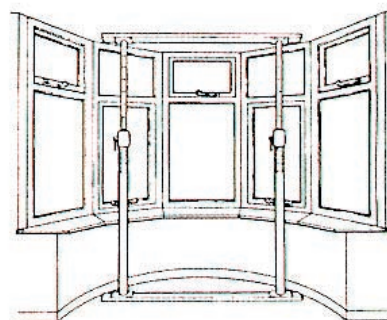

When the superstructure is supported, the window should be removed so as to cause minimum disturbance.

It is recommended that the load-bearing poles are removed one at a time and temporary supports are monitored for any movement.

Any trims removed should be replaced using the appropriate finishing trims



GENERAL - INSTALLATION

PREPARATION

Existing opening preparation

Before installing the window, the opening should be cleaned of all loose material, fillers or mastic.

Check the existing DPC is not damaged. If non-existent then one should be installed.

Damage caused by removal of windows should be repaired at the installers expense.

Defects noted during survey should be rectified as agreed at the time of survey.

New build opening preparation

The aperture should be completed before fitting the windows. Windows should not be used as a template for building. The Spectus Former may be used as a template.

Frame preparation

If frame packers are required they should be fitted before the cills.

If cills are required, there are two methods of fixing:

Cill to building first

The cill is positioned in the aperture and levelled. It is bedded on either a sealant or mortar bed.

A run of sealant is applied to the cill and across the ends before the window is fitted (see below)

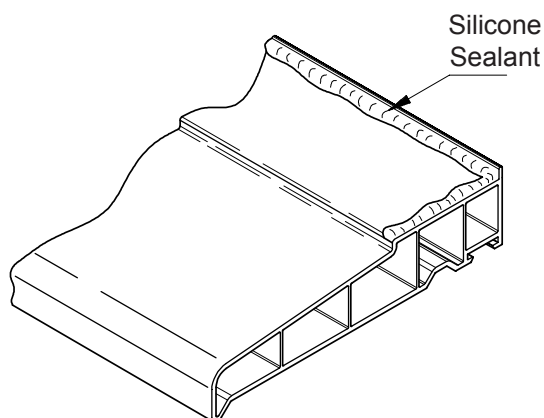

Cill to frame

The cill is cut to length (including the horns if required).

A run of sealant is applied on the frame (see below)

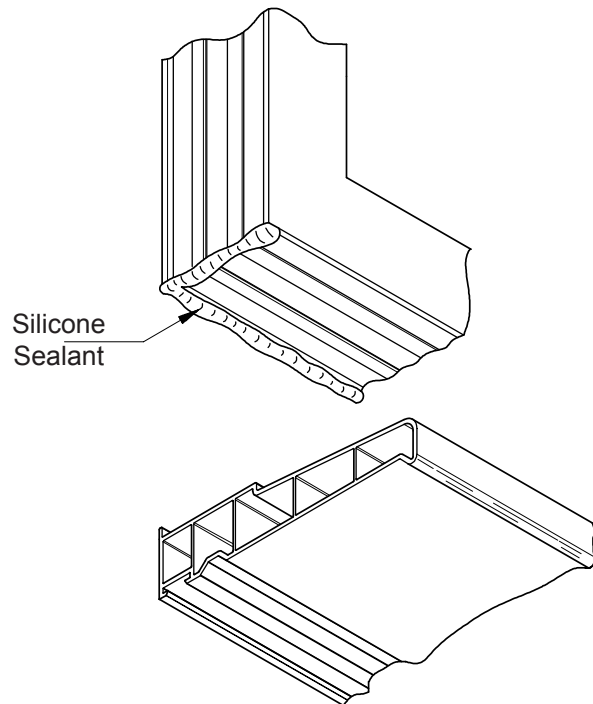

The cill is fitted using self-drilling screws (see below)

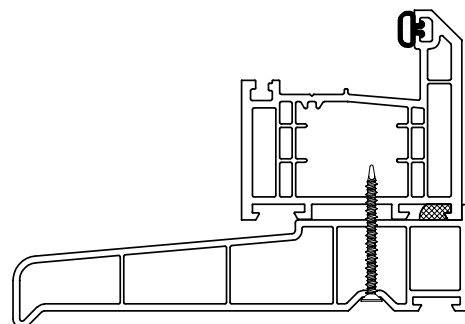

Fit the screws 150mm from the corners and at 300mm centres. Avoid screwing at the mullions.

Fit the cill end caps.



GENERAL - INSTALLATION

INSTALLATION

Position of window

On large contracts, agreement on window position should be reached before the start of any work.

The position should in general:

- bridge the cavity by a minimum of 30mm
- cover the DPC
- be set back a minimum of 10mm in the opening

When replacing narrow windows (e.g. steel windows) with PVC-U, it is necessary either to cut back the plaster or to fit odd legs to the frame to ensure the outside face of the window is set back from the building line.

Sequence

Make sure that the frame is square and true and not distorted.

Temporarily wedge the window in place.

Check the opening lights operate and do not foul the surrounds.

Methods of fixing

There are various methods of fixing available which may be used separately or in combination:

Through frame fixing

There are many types of suitable screws and plugs. The frame should be drilled and the inner face opened up to 13mm to allow cover caps to be fitted. The diagram below shows a typical woodscrew and plug fixing.

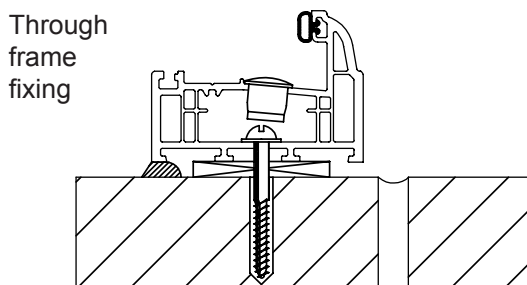

Lug fixing

Where lugs are to be bent to follow the building contours this should be carried out prior to clipping onto the frame to avoid distortion or damage. The following diagram shows a typical lug fixing.

Lug fixing

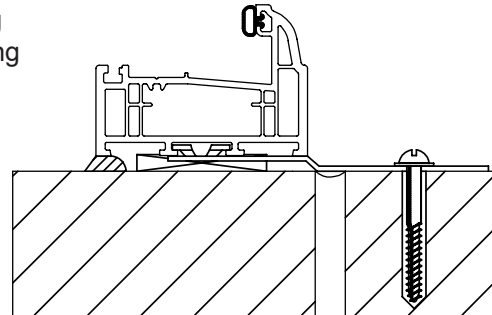

With either method of fixing, all fixings should be of a material and finish to offer high performance corrosion resistance.

Avoid distortion of the frame by using packing shims at the screw positions. The frame should be packed to ensure correct operation of opening lights and so as to not alter overlaps or clearances.

All fixings should penetrate the surrounding substrate by a minimum of 30mm.

All temporary wedges should be removed before the fixings are secured.

Fixing distance

The following general guidelines apply to fixings on all four sides of the frame:

The corner fixing should be a minimum of 150mm and a maximum of 250mm from the corner.

Intermediate fixings should be no greater than 600mm centres.

No fixing should be closer than 150mm, or further than 250mm to the centre line of mullions or transoms

There must be a minimum of 2 fixings on each jamb.

Fixing at cills

In general, fixings at the cill should be in accordance with the rules given in this section. However, when a sub cill is screwed to the cill section of the outer frame, the rules given for head fixings can be followed, providing an adequate silicone or mortar bed is provided.

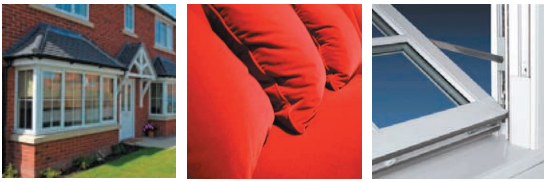

GENERAL - INSTALLATION

INSTALLATION

Special Cases

Polyurethane Foam

Experience has shown that fewer problems arise if fixings are used in accordance with page Gen.22. However, the presence of pre-cast concrete or steel lintels may make it impractical or pose severe difficulties in achieving the specified fixing distances. In these circumstances the use of polyurethane foam has proved a useful adjunct to mechanical fixings.

General Guidelines for Bow / Bay Windows

The rules for fixing and installation of flat windows also apply to bays with the following additions:

Site conditions and the size of the bay will determine if the bay is pre-assembled or assembled in situ.

Whichever method is used, checks must be made to ensure no loads are carried by individual segments.

Spacing of fixings to the bay pole or post should be as the general guidelines on page Gen.22.

Pre-assembly

If the bay is pre-assembled in the factory or on site prior to fitting, the following points should be followed:

Welded cills should be left oversize to allow for final cutting on site

All fixing centres should be as for flat windows

All joints between frames and cills should be silicone sealed.

Joints between frame packers/baypole adaptors and frames are siliconed.

Site assembly

Before final fixing of cills, windows should be positioned temporarily to check on the line of the cill and the window in relation to the structure of the building.

Typical bay assemblies

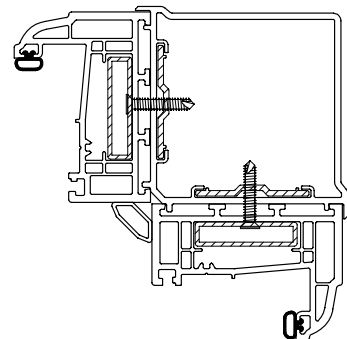
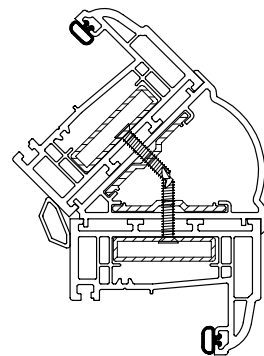
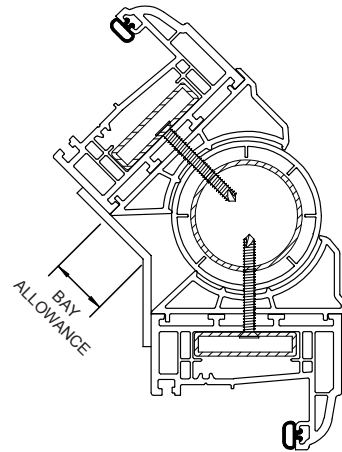



GENERAL - SAFETY

FIRE PERFORMANCE OF PVC-U WINDOW FRAMES

The following information has been supplied by the **BPF (British Plastics Federation)** and the **GGF (Glass and Glazing Federation)**:

● **Introduction**

PVC-U exhibits excellent fire behaviour and it does not burn once the source of heat or flame has been removed from it. This limited response to fire, coupled with a range of other attractive benefits (e.g. durability, toughness, rot-proof, dimensional stability, minimum maintenance) makes PVC-U an attractive material for window frames. Although the relevant UK Building Regulations and British Standards stipulate no fire performance standards for window frames, independent testing according to BS 476 Part 7: 1991 has shown that PVC-U window profiles can achieve a Class 1 rating.

● **Reaction-to-fire-hazards**

PVCu is very difficult to ignite using commonly available ignition sources (e.g. match, blow-lamp, chip-pan). Tests with a wide range of sources varying in heat intensity and impingement area on PVC-U window frames show that the product only burns whilst the source is applied. When the source is removed, there is no residual flame on the product. The table below shows that for a range of sources the PVC-U window frame only burnt within the impingement zone of the flame source.

Effect of applying flame ignition sources for 60 seconds to vertically orientated PVC-U window frame sections

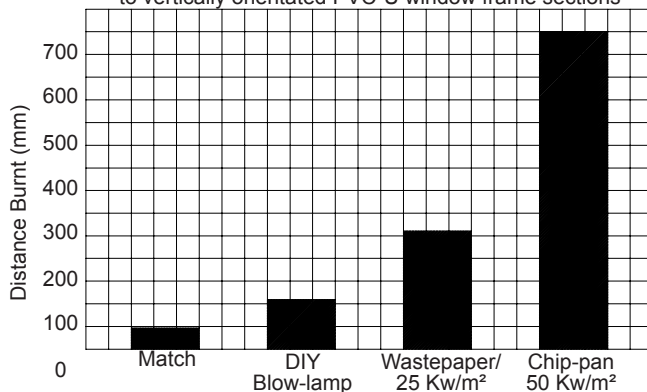

The limited burning of PVC-U is confirmed in a variety of other standard fire tests, which measure specific parameters such as rate of heat release and flame spread under different conditions.

The conclusions are:-

- (1) The rate of heat release and the total heat released by PVCu are significantly lower than most organic building materials.
- (2) When flames impinge on PVC-U, it forms a protective char which restricts the burning zone.

● **Smoke and fumes**

The rate of generation and quantity of smoke and fumes produced by a PVC-U window frame will depend on the severity of the external source of heat applied. The smoke and fumes emitted will be confined to the area of the product affected by this source and their transport away from the impingement zone will depend upon local factors such as ventilation and survival of the glazing.

● **Fire resistance**

The fire resistance of a glazed window is mainly influenced by the fracture behaviour of the glazing at high temperature. The fire resistance of glazed PVC-U window frames is generally found to be similar to that of glazed wood window frames.

● **Large-scale fire tests**

In a programme carried out at the Cardington Laboratory of the Fire Research Station, the performance of PVC-U window frames in fires has been compared to that of traditional wood frames in a room 3m x 3.3m x 2.4m high. All windows were double glazed. Two fire loads were used in the form of cribs built from wooden sticks, one weighing 30kg, the other 100kg, with low and higher ventilation conditions respectively.

The report drew the following conclusions:-

- (1) Little damage was evident to both PVC-U and wood windows until the glass panes were displaced. Glass panes failed by cracking and then falling out in a random manner.
- (2) After failure of one glass pane the increased ventilation accelerated fire growth and in most tests the other panes fell out shortly afterwards.
- (3) Wood frames burned after the displacement of glass while the PVC-U window frames softened and the casement sometimes fell out. There was some evidence of combustion of PVC-U. PVC-U windows did not show any aspects of performance which could create new hazards in fire involving buildings.
- (4) Carbon monoxide, produced mainly from the wooden crib under low ventilation conditions, was a major toxic hazard in each test and was produced in concentrations which could prove lethal in regions where ambient temperatures would allow survival.
- (5) The concentrations of carbon monoxide were noticeably lower in the fire involving only PVC-U frames; this was possibly caused by a low rate of burning in this test.
- (6) **Overall Conclusion** - PVC-U windows present a satisfactory performance in fires.



GENERAL - SAFETY

FIRE EGRESS FOR WINDOWS

Building Regulations Part B

Part B of the building regulations states any window provided for emergency egress purposes and any external door provided for escape should comply with the following conditions :-

- The window should have an unobstructed openable area that is at least 0.33m² and at least 450mm high and 450mm wide (the route through the window may be at an angle rather than straight through). The bottom of the openable area should be not more than 1100mm above the floor.

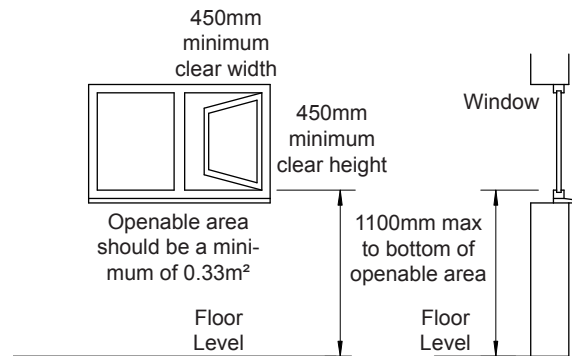

Note :- To achieve a minimum openable area of 0.33m², the minimum clear opening size is 450mm x 734mm

Fire Egress - Casement Window - Escape stay

To ensure a minimum 450mm wide opening when using Spectus profiles and fire egress escape stays the following minimum dimensions must be used :

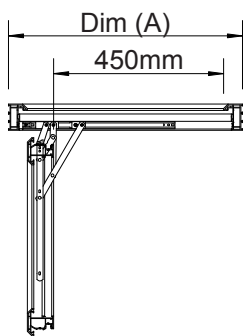

Outer frame to Outer frame

Dim (A) =
Back-edge of frame to
Back-edge of frame

Outer Frame	Dim (A)
Slim Outer	615mm
Intermediate Outer	635mm
Large Outer	655mm

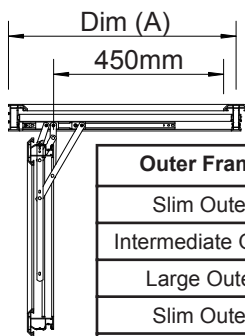

Outer frame to Mullion

Dim (A) =
Back-edge of frame to
centre line of mullion

Outer Frame	Mullion	Dim (A)
Slim Outer	Slim T/Z	600mm
Intermediate Outer	Slim T/Z	610mm
Large Outer	Slim T/Z	620mm
Slim Outer	*Intermediate T/Z	612mm
Intermediate Outer	*Intermediate T/Z	622mm
Large Outer	*Intermediate T/Z	632mm

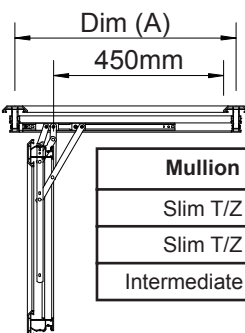

Mullion to Mullion

Dim (A) =
Centre line of mullion to
centre line of mullion

Mullion	Mullion	Dim (A)
Slim T/Z	Slim T/Z	580mm
Slim T/Z	*Intermediate T/Z	592mm
Intermediate T/Z	*Intermediate T/Z	604mm

* 90mm mullions used.

Fire Egress - Vertical Slider

To ensure a minimum 450mm height x 734mm width (0.33m²) opening when using the Spectus Vertical Slider the following minimum dimensions must be used :

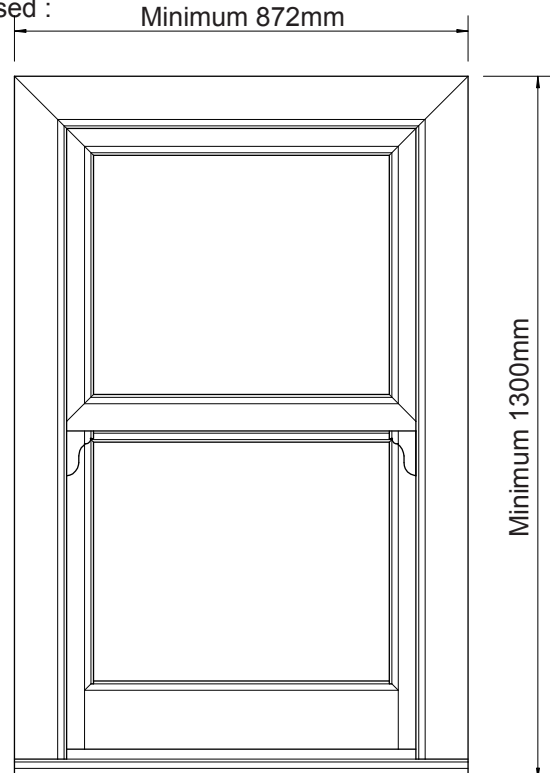

Alternatively, to achieve a minimum 734mm height x 450mm width (0.33m²) opening, the vertical slider must be a minimum of 588mm width x 1880mm height.

A vertical slider can achieve the requirements at a size of 920mm width x 1088mm height using special hardware. Specialist advice should be sought.

If a fire egress opening is necessary, this requirement must always be specified to the manufacturer.



GENERAL - SAFETY

ACCESS TO BUILDINGS

Building Regulations Part M

Effective clear width for doors

Part M of the building regulations states that entrance doors must have a minimum clear opening width of 775mm. It is important to take into account the pivoting action of the hinges.

Typically, to create a clear opening width of 775mm the outer frame width must be a minimum of 940mm.

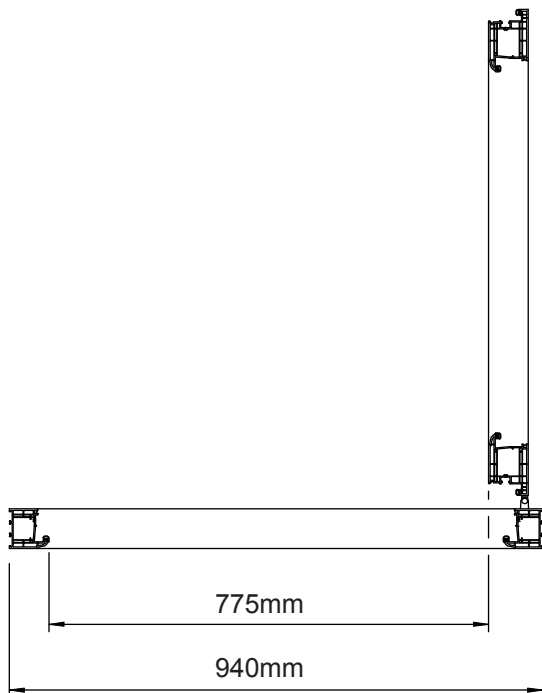

Accessible thresholds in new housing

The Part M document which gives guidance for house builders and designers states that the external leading edge of any proprietary threshold should be no higher than 15mm. The alternative is to demonstrate that the combined profile of the sill, lower threshold unit and the internal transition unit (when provided) meets the performance by suitable ergonomic testing.

Spectus has thresholds that will comply with this requirement.

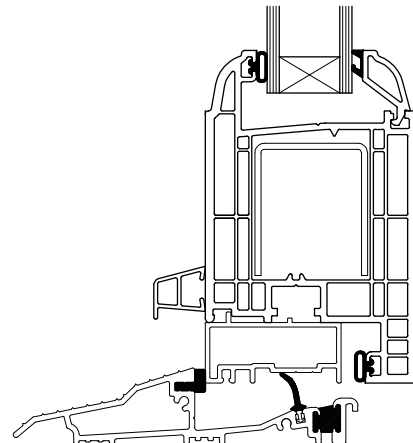



GENERAL - SAFETY

SAFETY GLASS

Building Regulations Part N1

Part N1 of the building regulations states that the following locations may be considered 'critical' in terms of safety :

- between finished floor level and 800mm above that level in the internal and external walls and partitions
- Between finished floor level and 1500mm above that level in a door or in a side panel, close to either edge of the door.

Glazing in these critical locations must either break safely, be robust or in small panes or be permanently protected.

In terms of safe breakage, a glazing material suitable for installation in a critical location would satisfy the requirements of Class C of BS 6206 or, if it is installed in a door or in a door side panel and has a pane width exceeding 900mm, the requirements of Class B of the same standard.

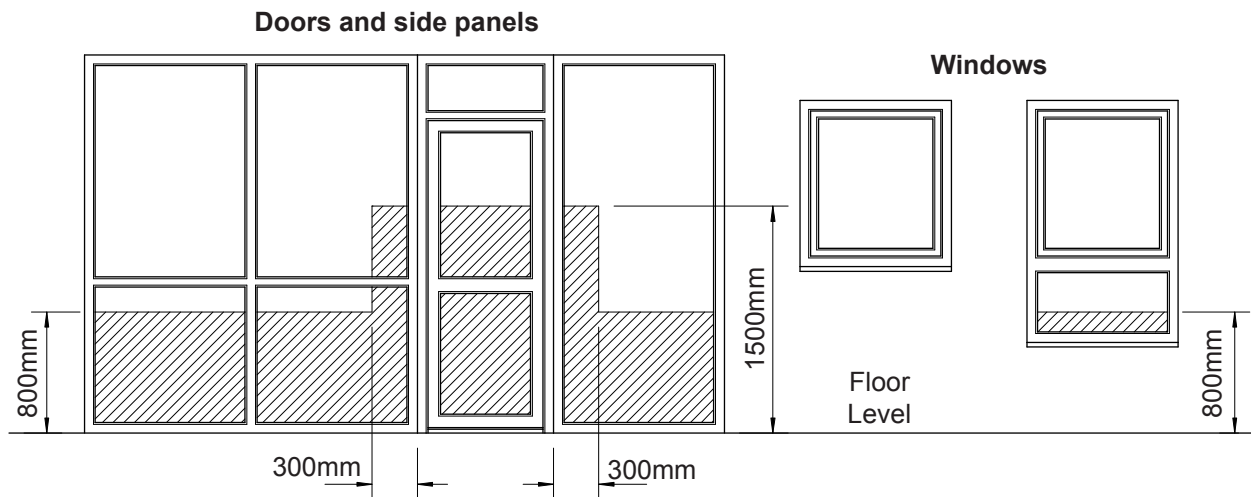



GENERAL - SAFETY

SAFE OPENING & CLOSING OF WINDOWS

Building Regulations Part N3

Part N3 of the building regulations, in accordance with Section 23(3) of the Health and Safety at Work, etc Act 1974, states that windows, skylights and ventilators which can be opened by people in or about the building shall be so constructed or equipped that they may be opened, closed or adjusted safely. This requirement does not apply to dwellings.

Location of controls

Windows will comply with building regulations if they satisfy the following requirements:-

- a. Where controls can be reached without leaning over an obstruction, they should not be more than 1.9m above the floor or other permanent stable surface provided to give access. Small recesses, such as window reveals, should be ignored.
- b. Where there is an obstruction the control should be lower, eg not more than 1.7m, where there is a 600mm deep obstruction (including any recess) not more than 900mm high.

Prevention of falls

Where there is a danger of the operator or other person falling through a window above ground floor level, suitable opening limiters should be fitted or guarding should be provided.

Location of controls

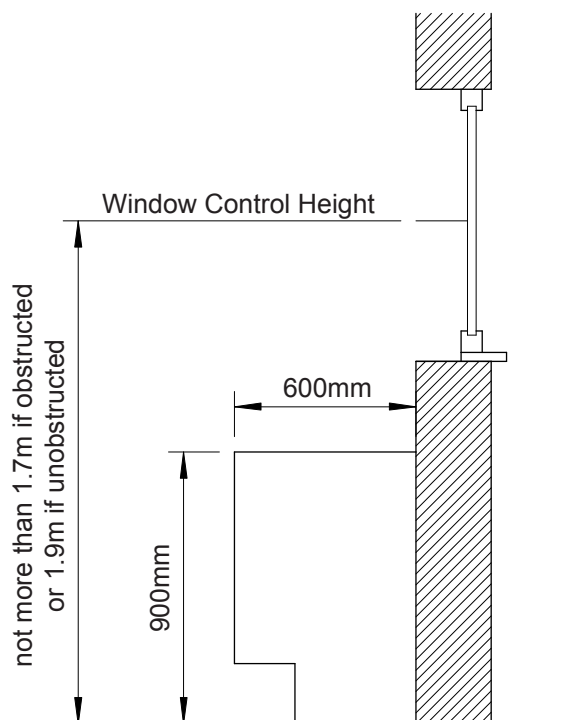



GENERAL - SAFETY

SAFE ACCESS FOR CLEANING

Building Regulations Part N4

Part N4 of the building regulations, in accordance with Section 23(3) of the Health and Safety at Work, etc Act 1974, states that provision shall be made for any windows, skylights, or any transparent or translucent walls, ceilings or roofs to be safely accessible for cleaning. This requirement does not apply to dwellings or any elements whose surfaces are not intended to be cleaned.

Complying with the regulations

Windows which cannot be cleaned safely by a person standing on the ground or a permanent stable surface will comply with building regulations as long as any of the following provisions are satisfied:-

a. provision of windows of a size and design that allow the outside surface to be cleaned safely from inside the building. Windows which reverse for cleaning should be fitted with a mechanism which holds the window in the reversed position.

b. provision of an adequate area of firm level surface, in a safe place, to allow the use of portable ladders not more than 9m long (measured from the ground to the upper support). Where ladders up to 6m long will be used, normal soil will provide a suitable standing surface. Where ladders over 6m long will be used, suitable tying or fixing points should be provided.

c. provision of walkways at least 400mm wide, either with guarding at least 1100mm high, or with anchorages for sliding safety harnesses

d. provision of access equipment such as suspended cradles or travelling ladders, with attachments for safety harnesses.

e. provision of suitable anchorage points for safety harnesses or abseiling hooks.

f. only in circumstances where other means cannot be used, space for scaffold towers should be provided, and located so that windows can be cleaned.

Safe reaches for cleaning from inside

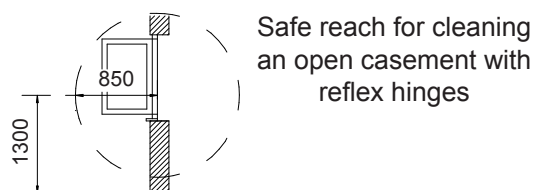
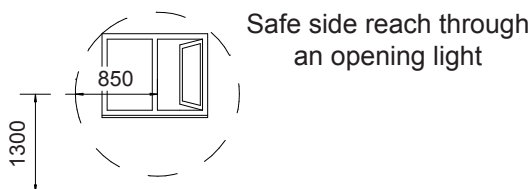
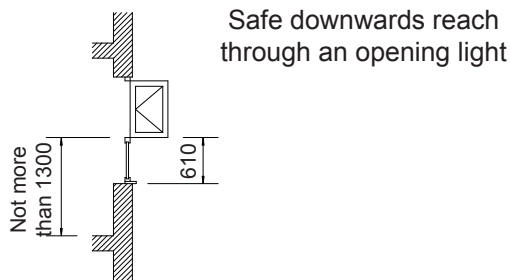

Ladders not more than 6m long

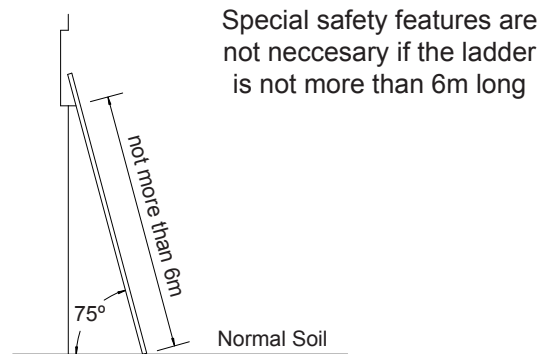

Ladders not more than 9m long

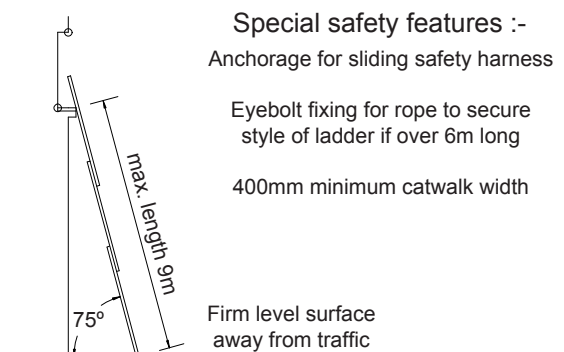



GENERAL - SAFETY

PROTECTION FROM COLLISION WITH OPEN WINDOWS

Building Regulations Part K4

Part K4 of the building regulations, in accordance with Section 23(3) of the Health and Safety at Work, etc Act 1974, states that provision shall be made to prevent people moving in or about the building from colliding with open windows, skylights or ventilators. This requirement does not apply to dwellings.

Complying with the regulations

Windows that project either internally or externally more than 100mm horizontally into spaces which are used by people moving in or about the building will comply with building regulations as long as any of the following criteria are met:-

- a. not less than 2m above the ground or floor when in any fixed position; or
- b. marked by a feature such as a barrier or rail about 1100mm high to prevent people walking into the projecting part; or
- c. marked by provision of surfaces with strong tactile differences, or by suitable landscaping features, so that people are guided away from them.

Marking by a barrier

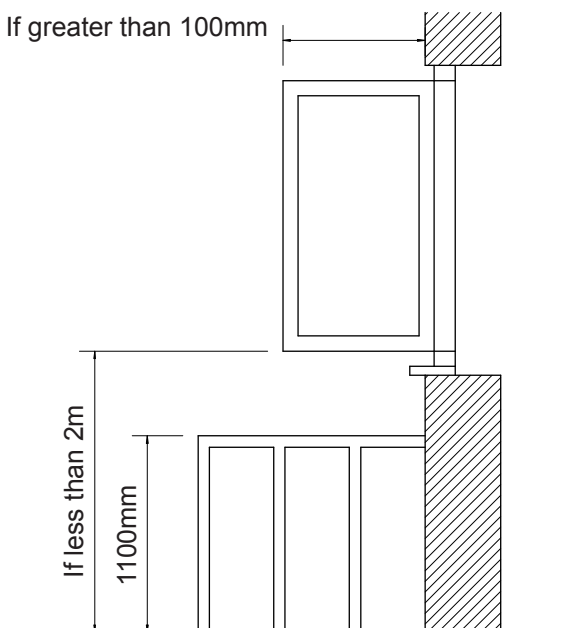

Spaces used only for maintenance

In spaces which are used infrequently, and only for the purpose of maintenance, provisions such as clear marking of the projecting part to make it easy to see will satisfy the requirement.

Marking by a surface

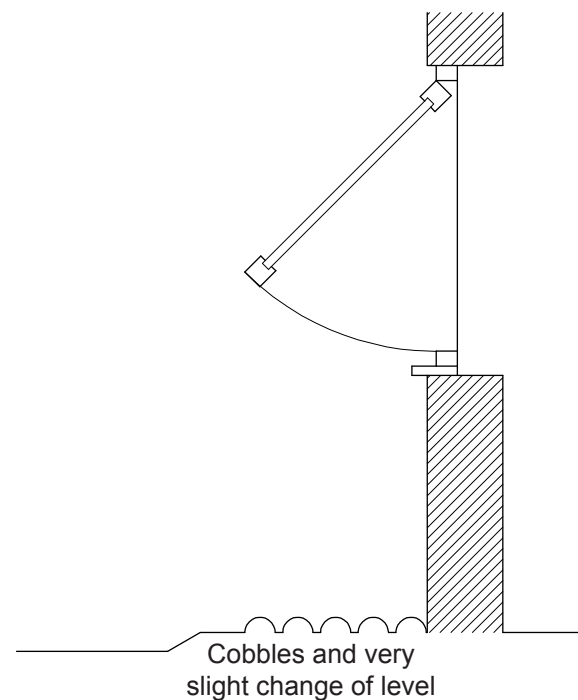



GENERAL - OPTIONS & GUARANTEE

DECORATIVE ANCILLARIES

The table below indicates which decorative ancillaries are available for each window system :-

	Elite 70	Reversible 70	Elite 63	Vertical Slider
Machined Sash Horn	•		•**	•
Face-Fix Sash Horn				•
Arched Heads	•*		•	
Clip-on Georgian Bar	•		•	
Stick-on Georgian Bar	•	•	•	•

* - Elite 70 Ovolo only

** - Elite 63 A32 Sash only

PROFILE FINISHES

The standard white colour for Spectus products is RAL No. 9016.

The table below indicates which woodgrain finishes are available from stock for each window system :-

Colour (Renolit EXOFOL MX)	Elite 70	Reversible 70	Elite 63	Vertical Slider	Ride Over Patio
Light Oak on white (2178 001-167)	•	•	•	•	•
Rosewood on white (3202 001-167)	•	•	•	•	•
White on white (9152 05-168)	•*			•	
Cream on cream (1379 05-167)	•*			•	
Light Oak on tan (2178 001-167)	•	•	•	•	•
Rosewood on brown (3202 001-167)	•	•	•	•	•

* - Elite 70 Ovolo only (Limited Range)

Non-Standard Foil Finishes

In addition to the standard range of stocked foils, that are shown above, Spectus Window Systems also offer the 'Spectrum' range of foils. This comprises a range of over 50 different coloured foils in a range of flat, timber grain and metallic effect finishes.

Any of these foils may be specified on any of Spectus Window Systems' products. They may even be specified to have different foils on the inside and outside of the windows and doors.

Advice should be sought to the effect on cost and lead time on a job by job basis.



GUARANTEE

Spectus Window Systems undertake to guarantee White & Woodgrain foil laminated PVC-U window and door profiles for a period of 10 years. This guarantee is in respect of colour stability in accordance with BS EN 12608.

This guarantee is conditional on the profiles being handled and applied in a proper way and in compliance with any instruction, specifications or guidelines that may from time to time be issued by Spectus Window Systems and provided they are maintained and installed in accordance with the BPF/GGF Trade Standard for PVC-U windows.

The guarantee period is effective from the date of extrusion.

This guarantee is only applicable when the resultant windows, doors and other fabricated products are installed in the UK, Channel Islands or Eire.

This guarantee only applies to products supplied by Spectus Window Systems and does not apply to window and door fittings or other ancillary items supplied by others.

This statement is only a brief outline of the Spectus Window Systems guarantee.



GENERAL - OPERATION & MAINTENANCE

CLEANING PVC-U PROFILES

Dirty marks on PVC-U frames can easily be removed by using the cleaning materials shown in the table below.

Cleaning cloths should be unbleached cellulose/cotton material. Do not use cloths containing synthetic fibres.

On woodgrain surfaces, care must be taken when cleaning. Any white areas showing, either through damage or cleaning, can be retouched using a woodgrain marker pen.

CONTAMINATION	CLEANING METHOD		
	Scrape off and polish with a dry cloth	Clean with water and mild detergent	Clean with non-abrasive household detergent and water
Pencil			•
Emulsion paint	•		
Felt pen			•
Organic grease			•
Inorganic grease			•
Plaster	•	•	
Woodstain		•	
Ball point pen			•
Cellulose paint	•		
Rust			•
Soot			•
Cement Mortar		•	
Wax pen		•	

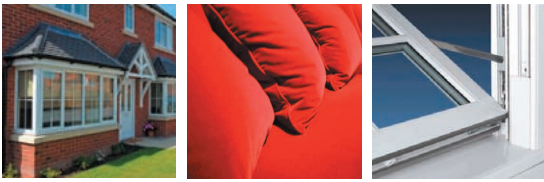

GENERAL - OPERATION & MAINTENANCE

CASEMENT WINDOWS

Friction Hinges

Maintenance is important but straightforward. Keep the friction stay track free from dirt and grime and keep the hinge mechanism clean. Lubricate the metal parts, regularly, with light oil, concentrating on the pivot points.

Friction can be increased or decreased by adjustment of the turning screw. Turn in a clockwise direction to increase friction. Take care not to over tighten.

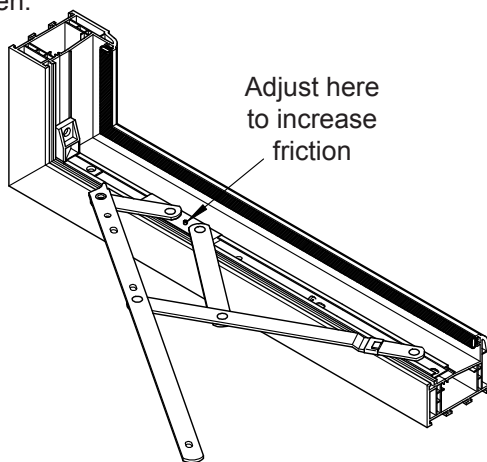

Egress Friction Hinges

In order to facilitate a maximum clear opening, egress hinges may be fitted. In most cases this will be an upstairs window and allows the window to be opened to 90°.

Some egress hinges combine the opening facility with an easy clean system, whereby the vent can be slid sideways to allow external cleaning to be carried out from inside.

To utilise the easy clean facility, open the window normally, then press and hold down the button on both hinges to release the restrictor hinge. Slide the sash across to allow egress.

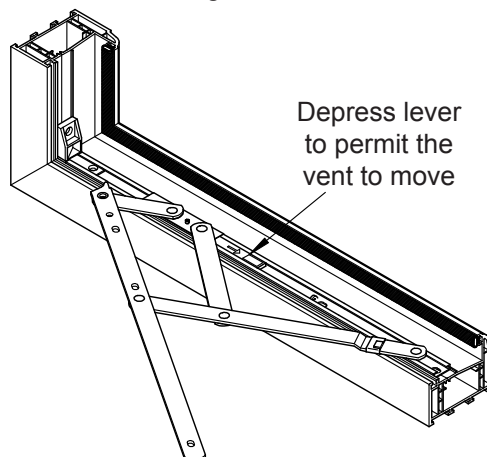

Window Locking Mechanisms

Windows fitted with either an Espagnolette or Shoot Bolt locking system will allow the window to remain partly open at night to facilitate ventilation.

To engage the window in its night vent position, open the window to approximately 15mm and then return the handle to its locking position. You may feel slight resistance so do not try to force the handle, simply move the window slightly until you find a point where there is no resistance, and close. Check the window is held securely in the night vent position by pushing gently on the vent - if held securely it should not move.

Maintenance of locking systems is simple: apply light oil to the moving parts, once a year. Similarly, a little grease should be applied to the locking slots to facilitate smooth running.

Ventilation Control

Windows can be fitted with a trickle ventilation unit, located at the top of the frame. This is designed so that you can control ventilation and minimise any build up of condensation. Simply open or close the ventilator by pushing the finger recess to the left or right. No maintenance is required.

Handles

Windows can be fitted with key locking, push to open handles. An easy to use system, yet secure and long lasting. To operate, simply press the thumb button, turn through 90° and push the window to the desired angle. To close, reverse the procedure by pulling the window closed and turning the handle back to the upright position, thus engaging it automatically. Handles can be deadlocked by using the key provided.

Note : Hardware should be operated and maintained strictly in accordance with manufacturers instructions



GENERAL - OPERATION & MAINTENANCE

RESIDENTIAL & FRENCH DOORS

Door Locking Mechanisms

Doors can be equipped with a hook or cam lock mechanism. In some cases there may be a split spindle lock - this means you cannot enter the house without using a key to open the door.

Locking

To operate the lock, insert the key into the cylinder. Rotate the handle upwards, turn the key for one complete revolution, to activate the deadbolt, which locks the whole mechanism. Release the handle.

Unlocking

Insert the key into the cylinder lock and disengage the deadbolt by turning one complete revolution. Depress the handle and open the door. Where a split spindle is fitted in addition, after you have depressed the handle, turn the key a further quarter revolution to release the latch.

Handle Options

Traditional front doors can be fitted with an external pull-pad operated handle with a lever operated internal handle. Back doors are usually fitted with a lever operated handle both internally and externally. Maintenance of the locking systems is simple: apply light oil to the moving parts, once a year. Similarly, a little grease should be applied to the locking slots to facilitate smooth running.

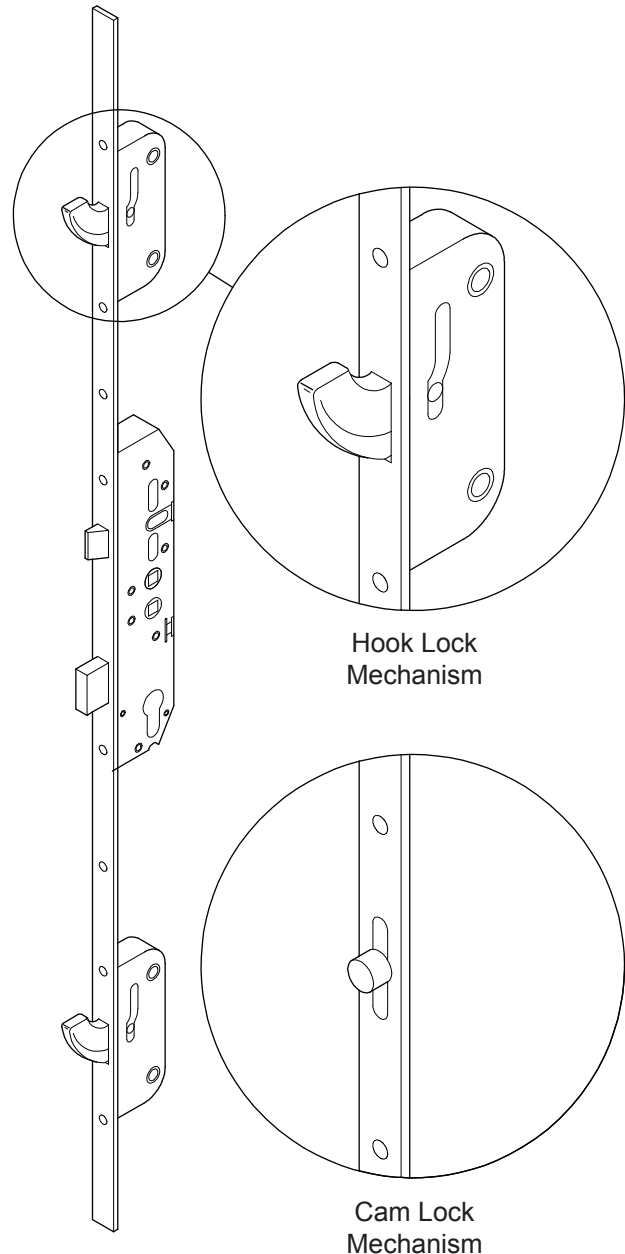

Note : Hardware should be operated and maintained strictly in accordance with manufacturers instructions



GENERAL - OPERATION & MAINTENANCE

TILT & TURN WINDOWS

Tilt & Turn Mechanism

Maintenance is important but straightforward. Keep the locking mechanism clean and free from dirt and grime. Lubricate all locking points and strikers regularly with light oil to facilitate smooth running.

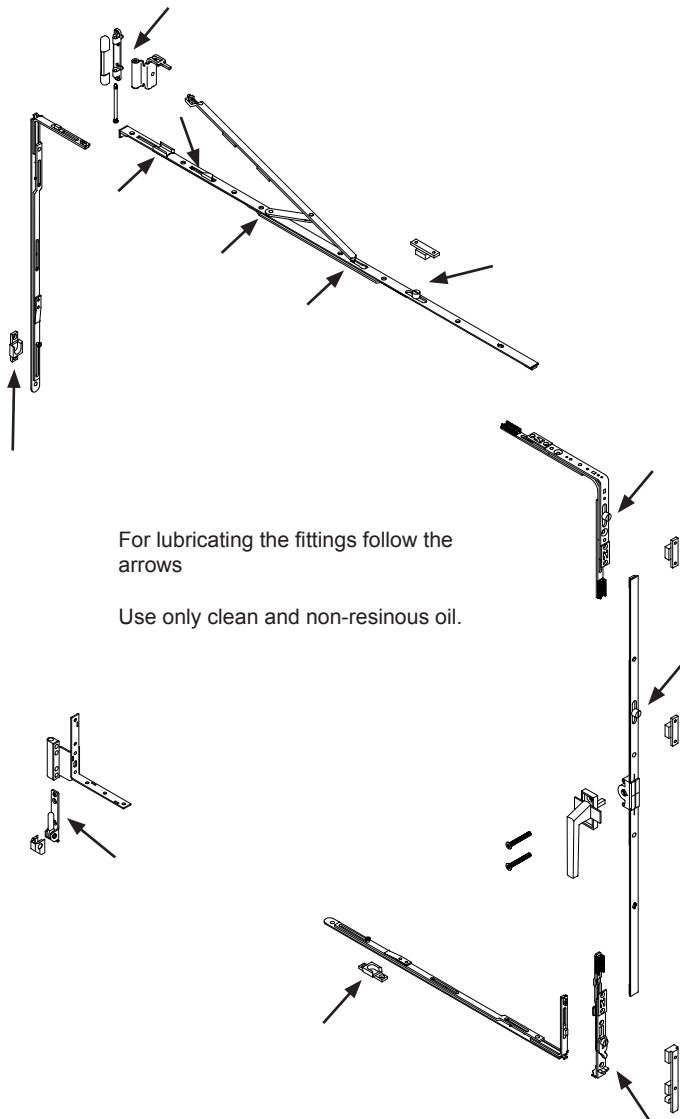

For lubricating the fittings follow the arrows

Use only clean and non-resinous oil.

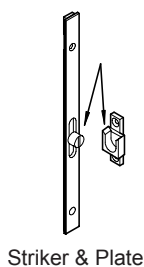

Striker & Plate

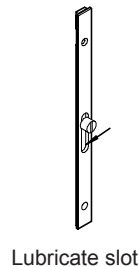

Lubricate slot

Window Operation

The window is taken into the tilt position for ventilation by unlocking the handle (if required) and moving it, through 90°, to the first position. The window is then pulled gently inwards tilting on its lower edge. Any slight resistance felt at this stage is caused by the anti-slam device that prevents the window being blown shut when subjected to higher wind pressures.

To close the window it is pushed shut and then secured by turning the handle back to the closed position.

The window is taken into the turn position for cleaning. This is done as above but the handle continues to turn through 180° to the upright position. The window can then be hinged in to allow cleaning of the window from inside.

To close the window reverse the above procedure. It must be stressed that this position is for cleaning only and should not be used for ventilation.

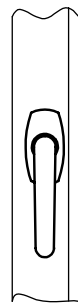

Closed Position

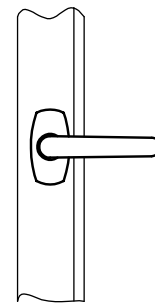

Tilt Position



Turn Position

NOTE:

The above operation is for "Tilt before Turn" or "Tilt First" gear. "Turn before Tilt" or "Turn First" gear is also available although less common. If this is fitted the handle position shown above for the tilt position & turn position would be reversed.

Ventilation Control

Windows can be fitted with a trickle ventilation unit, located at the top of the frame. This is designed so that you can control ventilation and minimise any build up of condensation. Simply open or close the ventilator by pushing the finger recess to the left or right. No maintenance is required.

Note : Hardware should be operated and maintained strictly in accordance with manufacturers instructions



GENERAL - OPERATION & MAINTENANCE

REVERSIBLE WINDOWS

Reversible Mechanism

The hinge side rails are to be kept clean and free from dirt & grit. Do not paint these rails. Apply light oil to the pivot points approximately twice a year.

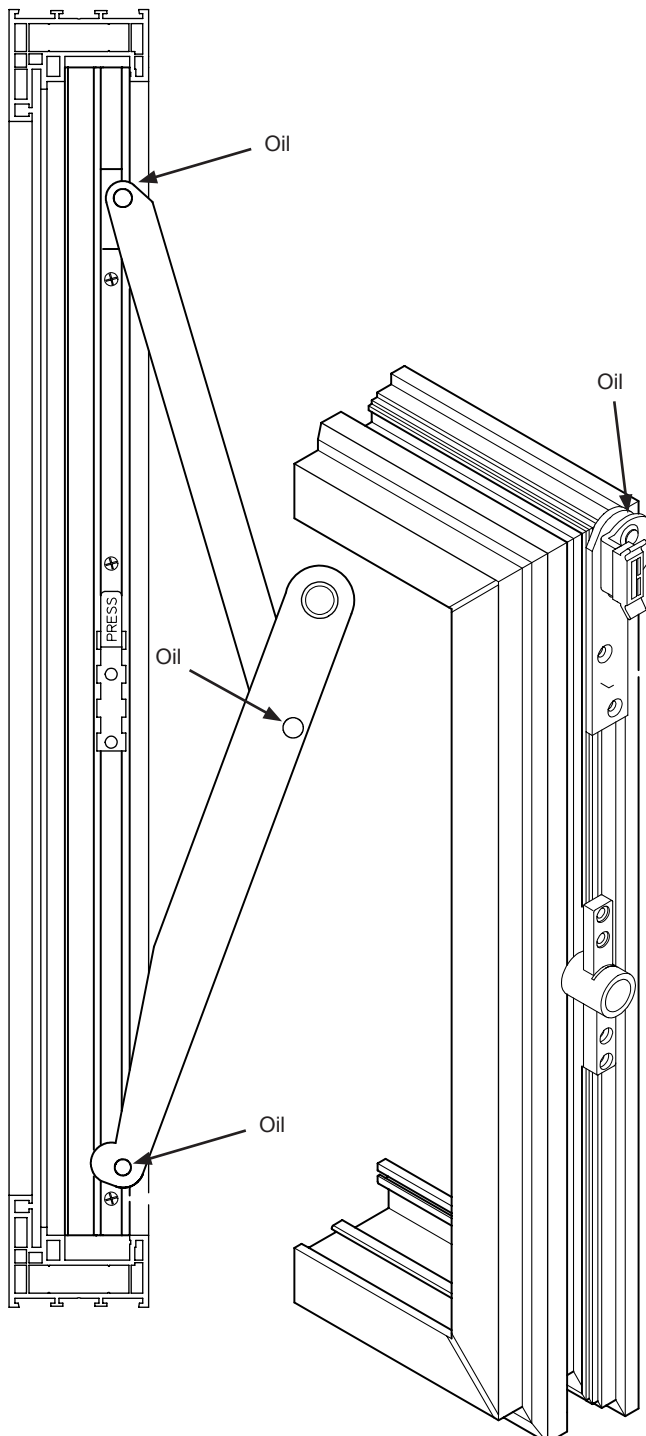

Window Operation

The window is opened by unlocking the handle and moving it, through 90°. The window is then pushed outwards and will stop in the first ventilation position. If more ventilation is required, the button on the left hand side is depressed allowing the window to be pushed further open into the next position.

If just background ventilation is required, this can be achieved by engaging the “night vent” position. This is done by opening the handle, pushing the window open approximately 20mm, and re-closing the handle.

To close the window it is pulled shut and then secured by turning the handle back to the closed position. It is necessary to depress the button on the left hand side to close the window.

The window is taken into the reversed position for cleaning. This is done by opening as above for ventilation but at the second position depress the button again and push the window further open. The head of the window can now be gripped and pulled down to fully reverse the window. It should click into place in this position to provide safe cleaning from inside the building. Do not attempt to clean the window in the reverse position until the safety catch is engaged.

To close the window after cleaning, press the button and push the top of the window out. The bottom can now be gripped and the window pulled into the ventilation position.

Ventilation Control

Windows can be fitted with a trickle ventilation unit, located at the top of the frame. This is designed so that you can control ventilation and minimise any build up of condensation. Simply open or close the ventilator by pushing the finger recess to the left or right. No maintenance is required.

Note : Hardware should be operated and maintained strictly in accordance with manufacturers instructions



GENERAL - OPERATION & MAINTENANCE

VERTICAL SLIDER

Vertical Slider Mechanism

The hardware requires simple lubrication. An application of light oil will keep the locking mechanisms and keeps in good working order.

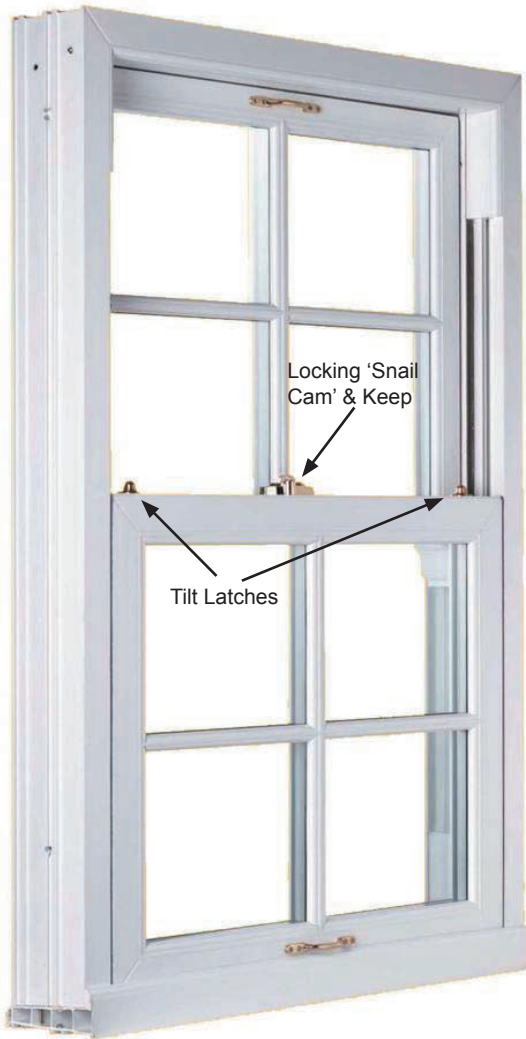

Window Operation

The window is opened for ventilation by unlocking the snail cam(s) located on the top face of the bottom sash using the key provided (if key locking versions are fitted). Turn the cam(s) until released from the keep(s).

The bottom sash may now be slid upwards and/or the top sash may be slid downwards.

To close the window slide both sashes fully closed and re-engage the snail cam(s).

Window Operation (continued)

The window is opened into the cleaning position by opening the bottom sash to approximately 100mm (as previously described). Both tilt catches are then slid inwards releasing the top of the sash. This can then be pulled inwards and rested on its restrictor to allow safe cleaning of the glass from inside the building.



The top sash can now be slid down. Both of its tilt catches are then slid inwards releasing the top of this sash. This can then be pulled inwards and rested on its restrictor to allow safe cleaning of the glass from inside the building.

Ventilation Control

Windows can be fitted with a trickle ventilation unit. This is designed so that you can control ventilation and minimise any build up of condensation. Simply open or close the ventilator by pushing the finger recess to the left or right. No maintenance is required.

Note : Hardware should be operated and maintained strictly in accordance with manufacturers instructions



GENERAL - ENVIRONMENT

ENVIRONMENTAL POLICY

The following statement represents Spectus Window systems environmental policy:

Spectus Environmental Policy

Spectus Window Systems aims to promote and maintain an Environmental Policy to ensure that any impact of our business upon the environment is reduced to as low a level as possible.

The awareness of our environmental impact is a responsibility of all our employees at every level within the company. All personnel will have an obligation to apply operating procedures and practices that will ensure the protection of the environment and the health and safety of their selves and their colleagues.

In the event of an environmental incident, all details will be correctly reported and investigated, with prompt actions taken to remedy the situation and to avoid recurrence.

Objectives

Spectus Windows Systems objectives are to be achieved using the best available practices:-

- To comply with national/international legislation, local regulatory controls and any relevant industry standards.
- To prevent pollution and react swiftly to any incidents, to minimise any threat to the environment.
- To reduce levels of waste produced and to dispose of any waste in a safe and responsible way.
- To develop and maintain an Environmental Management System, maintained by regular audits and reviews of the objectives and targets.
- To continually improve the measures to prevent pollution and waste.

Spectus Window Systems will aim to adopt best available practices for the reduction of emissions to Air, Water and Land, and for the conservation of Water and Energy.

GENERAL ENVIRONMENTAL

General Environmental Information

Steel reinforced PVC-U windows achieve an A rating for domestic use and an A+ rating for commercial use in the Building Research Establishment (BRE) Green Guide to Specification.

Couple these ratings with a reference service Life of at least 35 years and it can be seen that PVC-U windows have impressive sustainability credentials.

PVC-U windows are recyclable up to ten times and a growing infrastructure of recyclers is able to handle used PVC quite easily.

The PVC industry's Voluntary Commitment, Vinyl 2010, and its successor project VinylPlus have firmly established the recycling of PVC building products in the UK.

In 2010, at the end of the Vinyl 2010 project, almost 25,000 tonnes of PVC-U window frames were recycled in the UK.

Additionally, many PVC-U windows are not only light in weight, they are manufactured locally to the installation site, therefore minimising transport costs and vehicle emissions.

Spectus commitment

Spectus is fully committed to ISO 14001, which covers the full spread of environmental issues including waste water, noise, fuel use, refuse, air quality, disposal and recycling.