

CODE	DESCRIPTION
01	DESIGN AND CONSTRUCTION (NOT FOR CONSTRUCTION)
02	SUITABLE FOR COORDINATION
03	SUITABLE FOR INFORMATION
04	SUITABLE FOR REVIEW AND COMMENT
05	SUITABLE FOR STAGE REVIEW AND APPROVAL
06	SUITABLE FOR STAGE REVIEW AND ACCEPTANCE
07	FOR CONSTRUCTION
A1	STAGE 1 AUTHORIZED (NOT FOR CONSTRUCTION)
A2	STAGE 2 AUTHORIZED (NOT FOR CONSTRUCTION)
A3	STAGE 3 AUTHORIZED (NOT FOR CONSTRUCTION)
A4	STAGE 4 AUTHORIZED (NOT FOR CONSTRUCTION)
A5	STAGE 5 AUTHORIZED (NOT FOR CONSTRUCTION)
A6	STAGE 6 AUTHORIZED (FINAL DESIGN RECORD)

NOTES

- THIS DRAWING IS FOR INFORMATION AND MAY NOT BE REPRODUCED WITHOUT THE PERMISSION OF MANN WILLIAMS
- ALL DCG (DESIGN CHECK) TAGS SHALL BE COMPLETED OUT IN ACCORDANCE WITH THE DESIGN CHECK STANDARD AND CODES OF PRACTICE
- ANY DISCREPANCIES OR INCONSISTENCIES BETWEEN THIS DRAWING AND ANY OTHER DRAWINGS SHALL BE REPORTED TO THE DESIGNER BEFORE ANY COMMENCEMENT OF WORK
- ALL DIMENSIONS SHALL BE IN METERS UNLESS OTHERWISE SPECIFIED
- ONLY MATERIALS AND METHODS SPECIFIED SHOULD BE USED AND NO SUBSTITUTIONS OR OMISSIONS SHOULD BE MADE

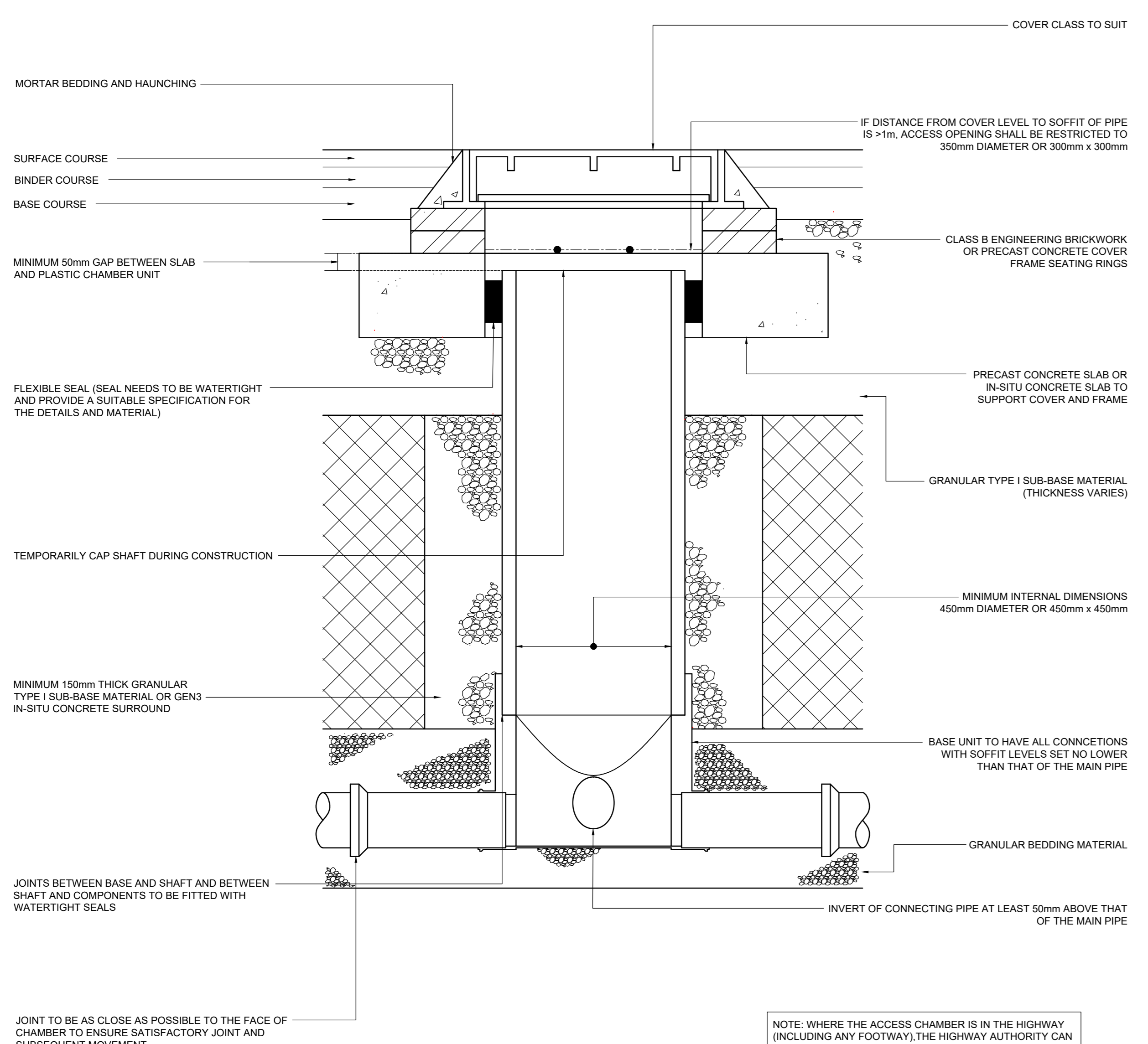

SECTION 01A TYPICAL INSP. CHAMBER ROADWAY
1:10

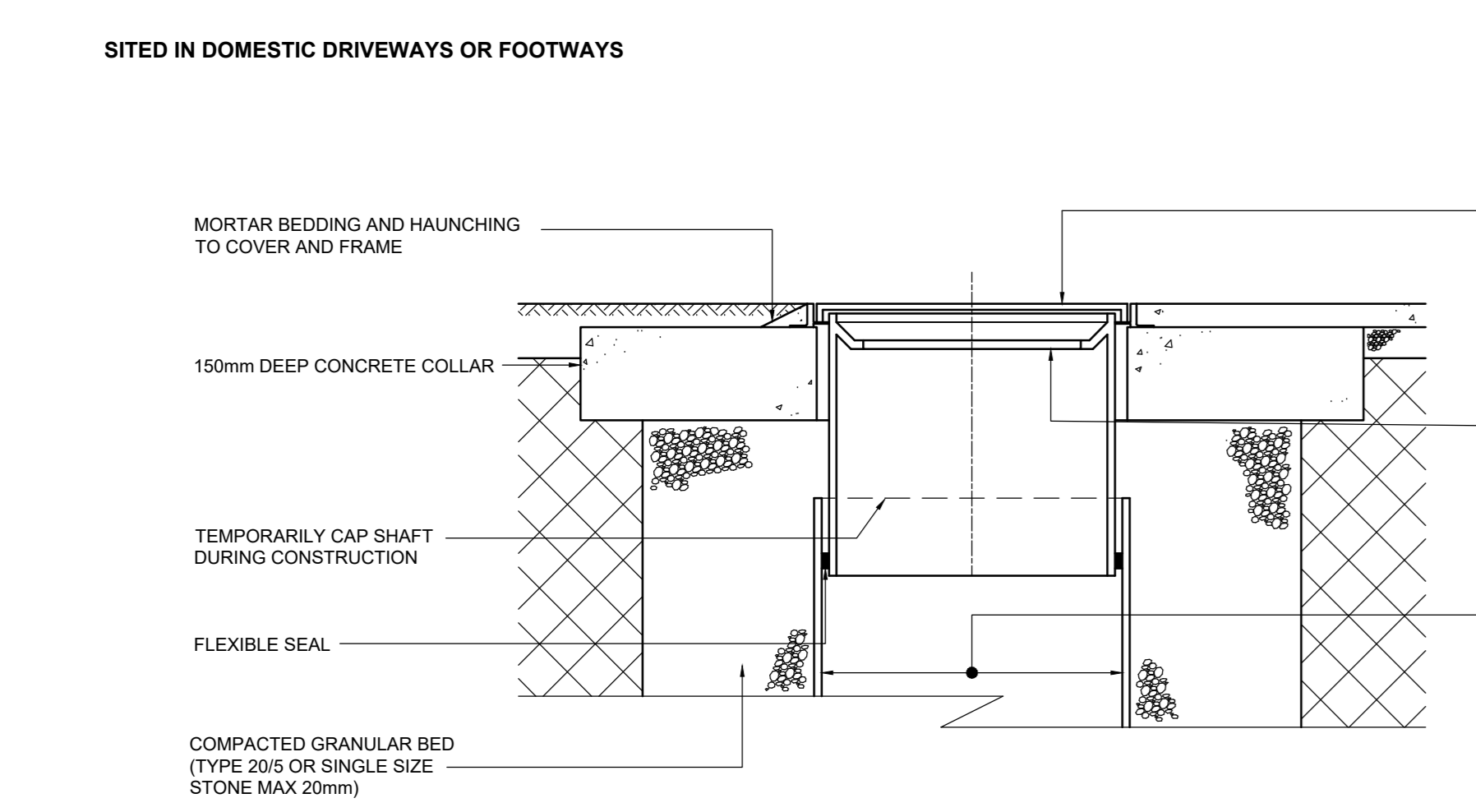

SECTION 01B TYPICAL INSP. CHAMBER DRIVEWAY/FOOTPATH
1:10

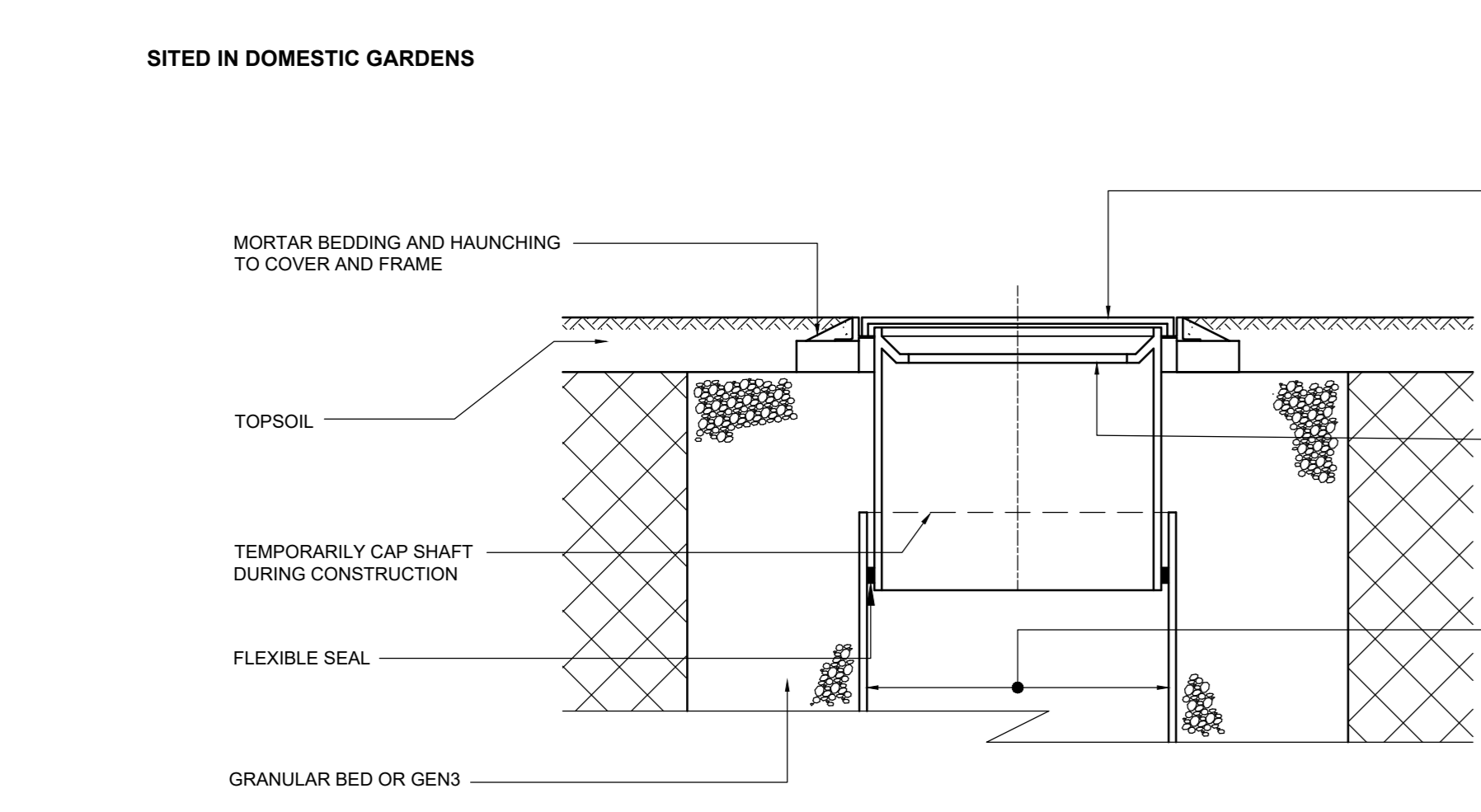

SECTION 01C TYPICAL INSP. CHAMBER LANDSCAPED AREAS
1:10

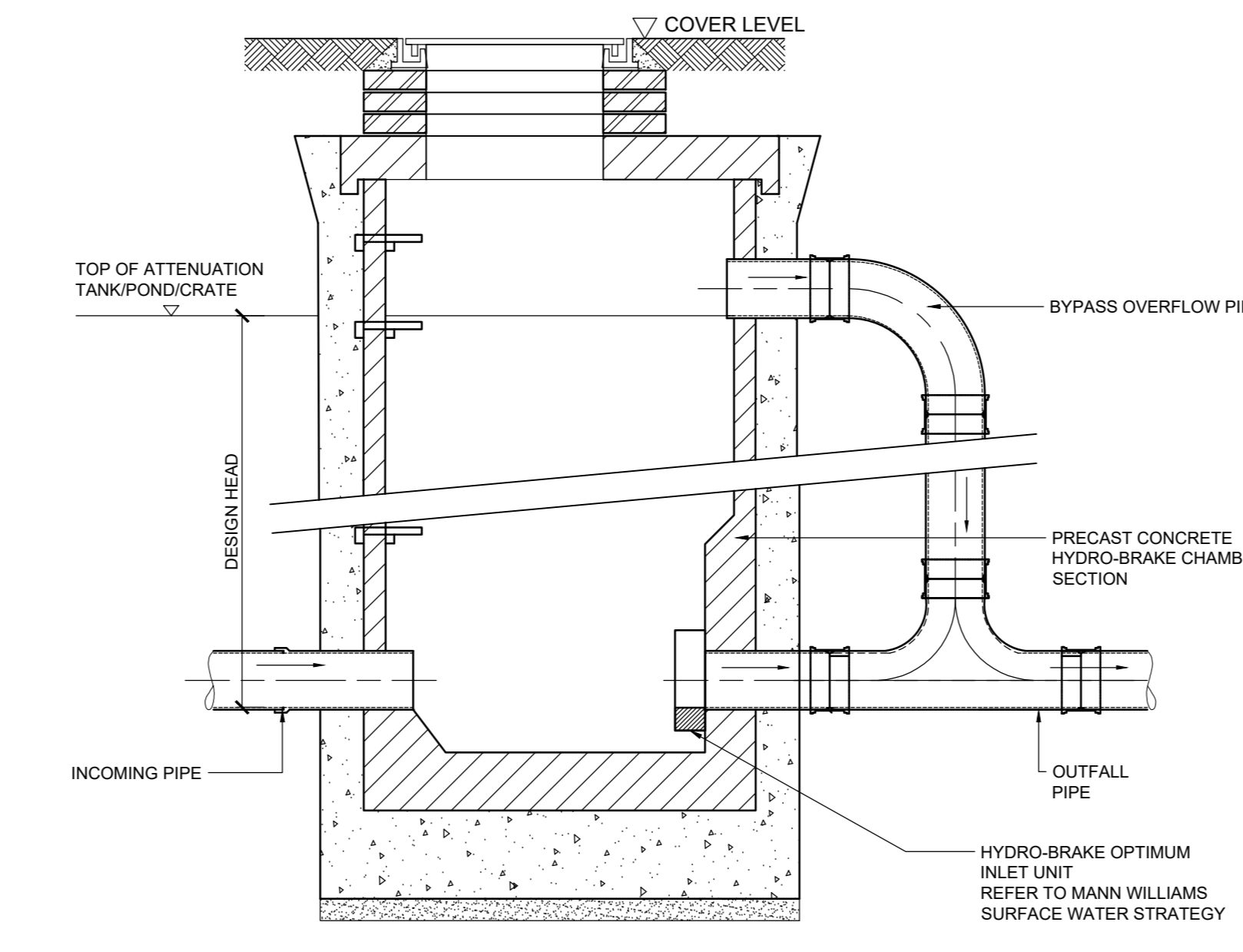

DETAIL 02 FLOW CONTROL MANHOLE TYPICAL DETAIL
1:20

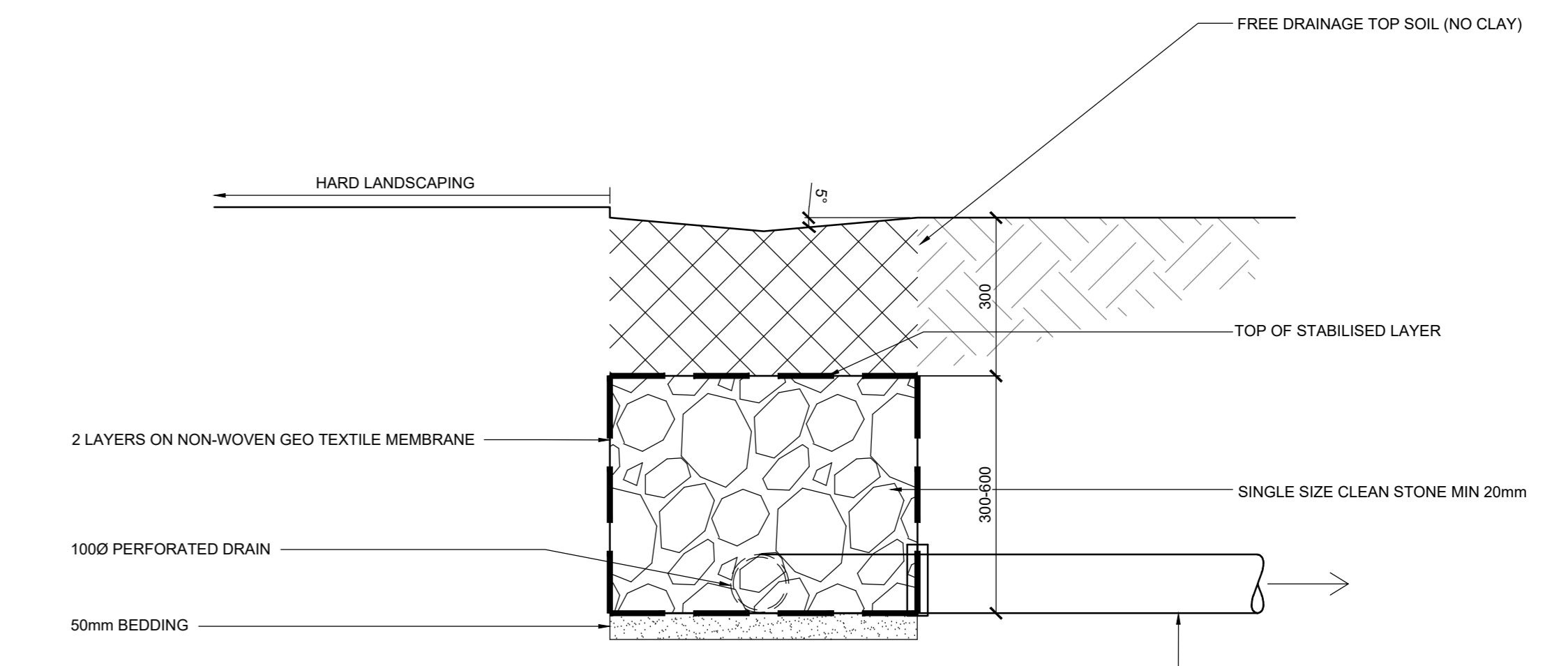

SECTION 03 BURIED FRENCH DRAIN
1:10

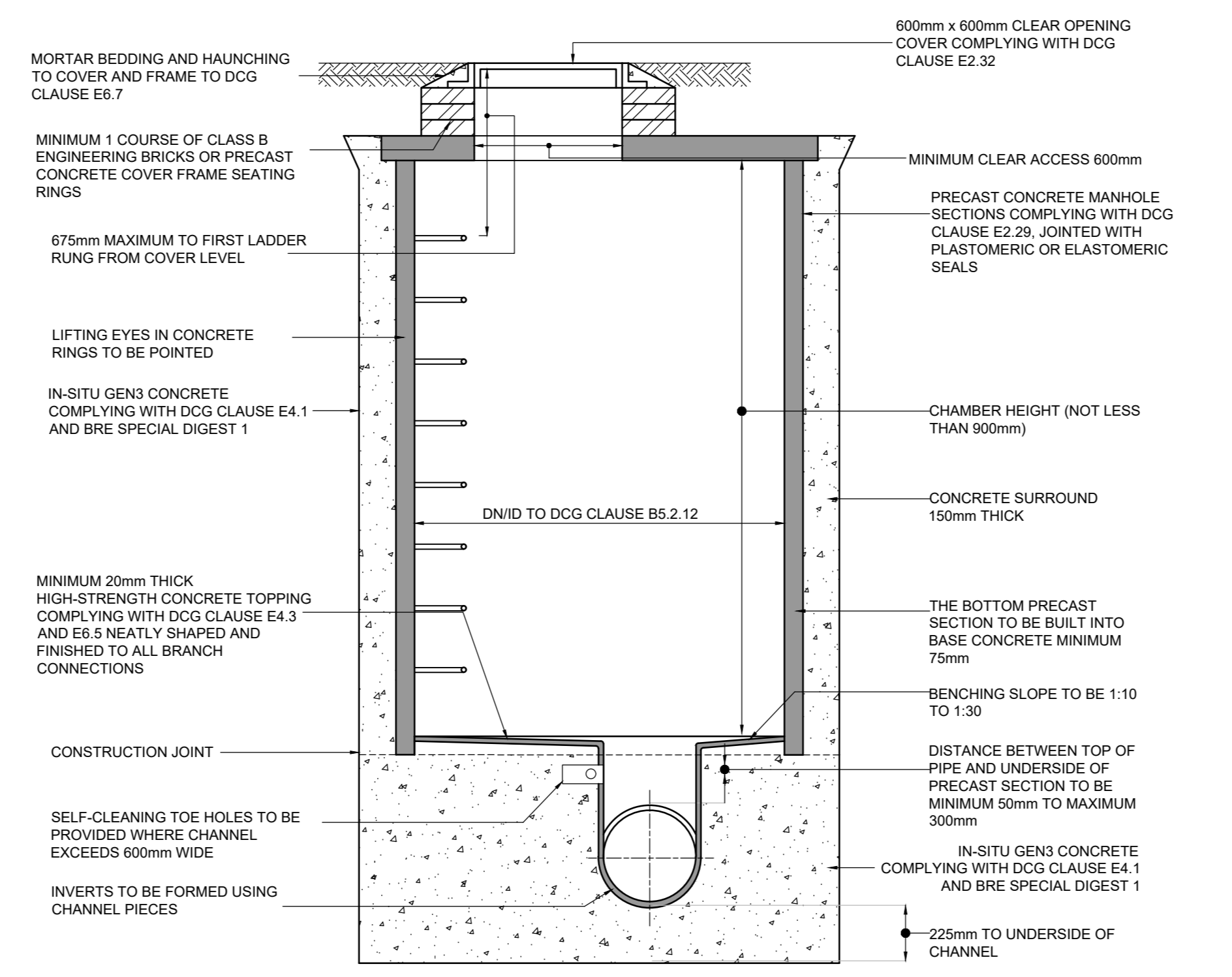

SECTION 04 ADOPTABLE MANHOLE
1:20

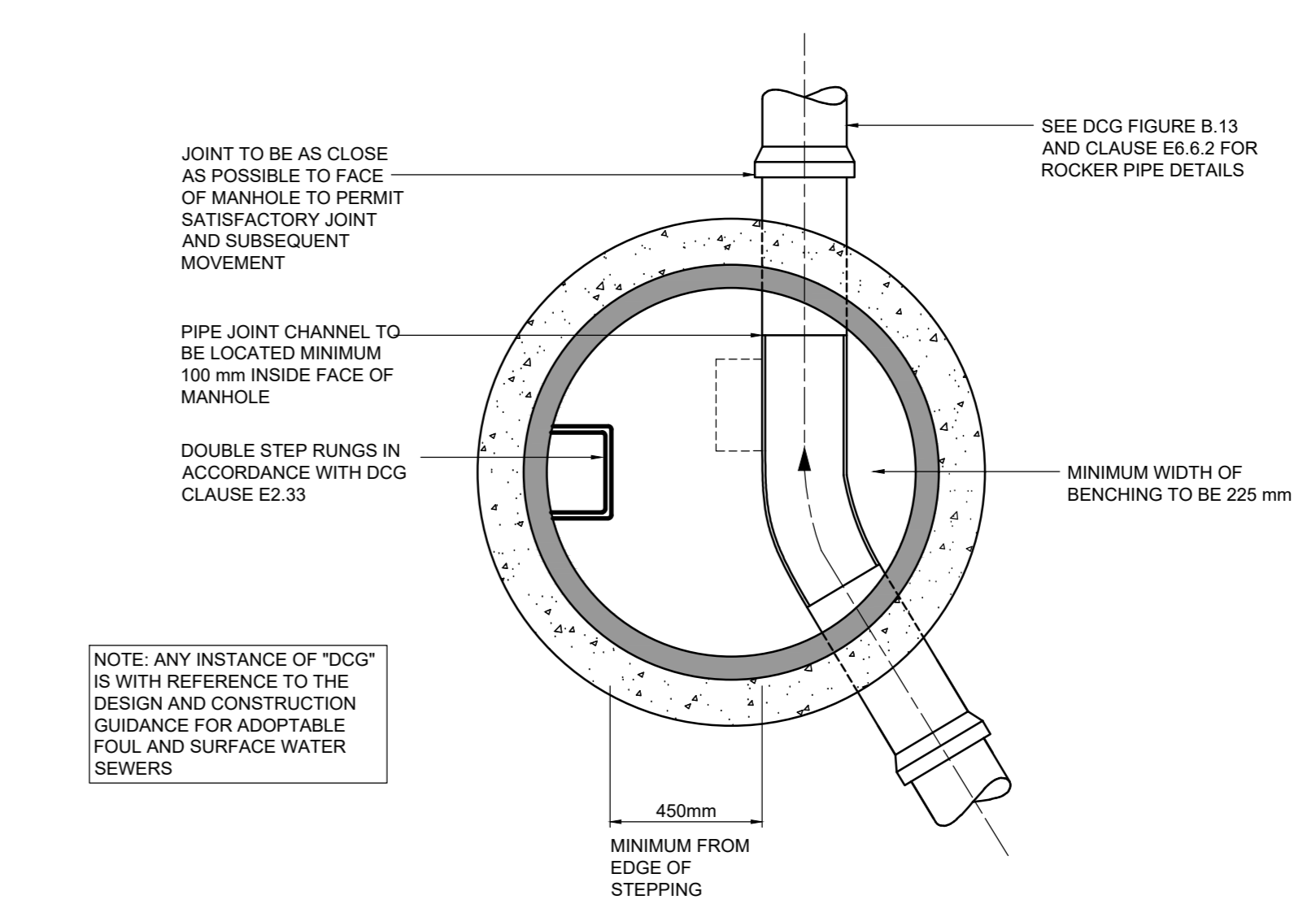

PLAN 05 ADOPTABLE MANHOLE
1:20

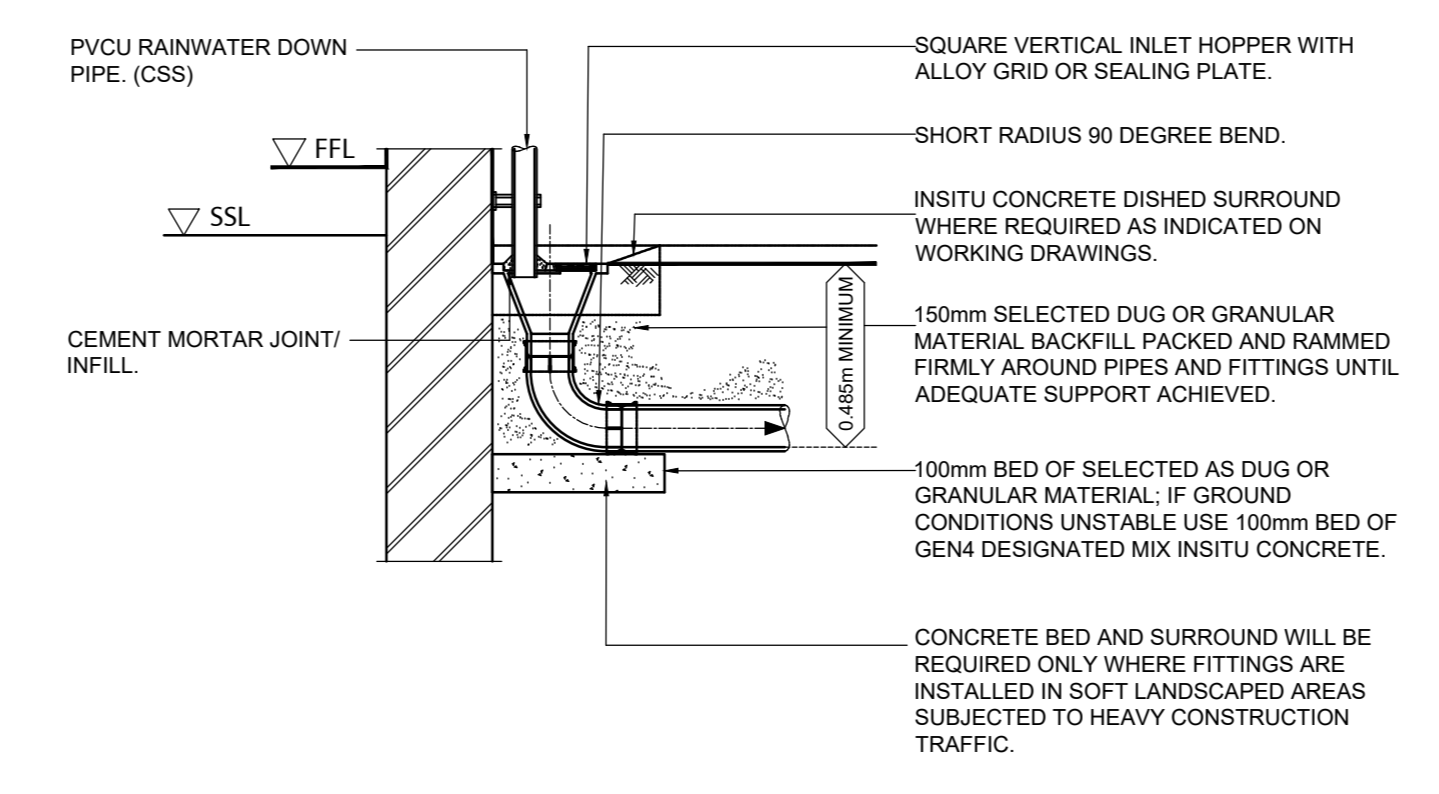

DETAIL 06 DIRECT RAINWATER CONNECTION THROUGH GULLY
1:20

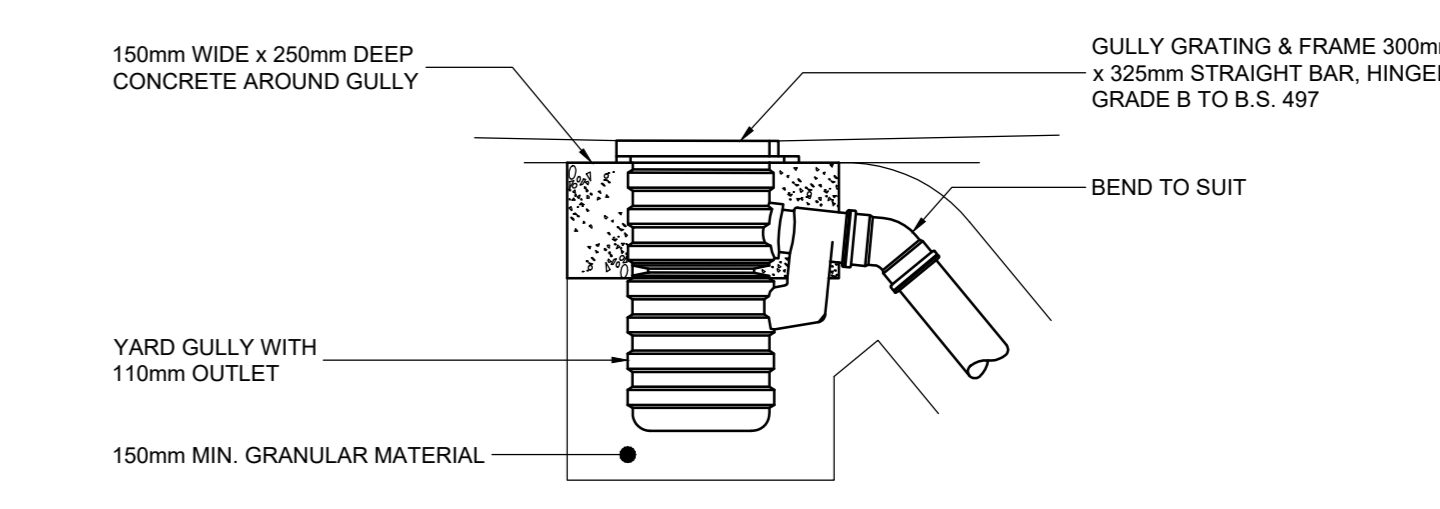

DETAIL 07 YARD GULLY
1:20

DRAWING TO BE READ IN COLOUR

REV	DESCRIPTION	DATE
P1	PRELIMINARY ISSUE	JL 15.09.23
T1	TENDER ISSUE	JL 20.10.23
T2	TENDER ISSUE	JL 08.11.23
T3	TENDER ISSUE	JL 20.11.23
T4	TENDER ISSUE	JL 21.11.23

PROJECT
THE SHOEMAKERS MUSEUM
THE GRANGE

TYPE
DETAILS DRAINAGE
SHEET 1

MANN WILLIAMS CONSULTING CIVIL AND STRUCTURAL ENGINEERS
7 OLD KING STREET
QUEEN'S SQUARE
BATH BA1 2JW
T 01225 464419
E bath@mwmlliams.co.uk
W www.mwmlliams.co.uk

DATE	SCALE	NO.	REV.	DATE
JL	MRP A0			SEPT 2023 11439

A4 TENDER				
DESIGNER	CHK	DR	APP	DATE
GRA	XX	DR	D	MNW
REVISED				