

CODE	DESCRIPTION
01A	EXISTING MASONRY WALL
01B	EXISTING ASPHALT BUILD UP
01C	NEW BUILDING

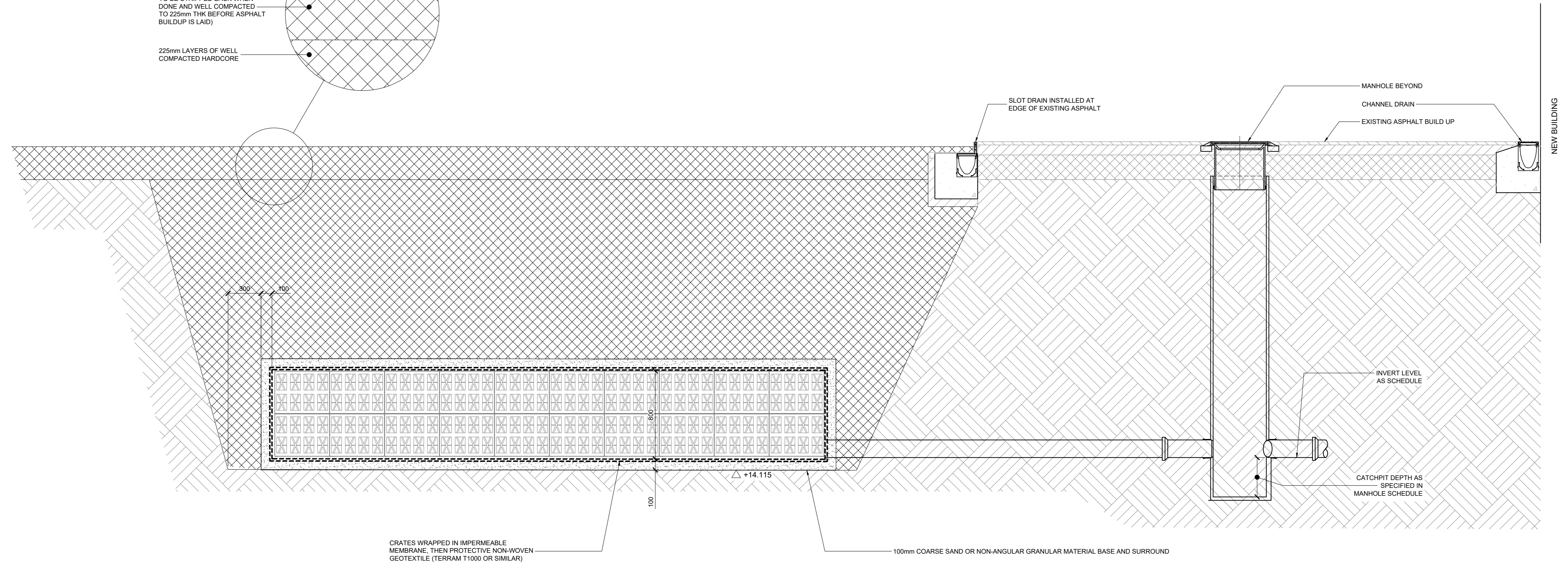

- NOTES**
- THIS DRAWING IS COPYRIGHT AND MAY NOT BE REPRODUCED WITHOUT THE PERMISSION OF MANN WILLIAMS
 - ALL DRAWINGS ARE TO BE READ IN CONJUNCTION WITH THE SPECIFICATION AND THE CONTRACT DOCUMENTS AND CONDITIONS OF CONTRACT
 - ANY DISCREPANCIES OR INCONSISTENCIES BETWEEN THIS DRAWING AND ANY OTHER CONTRACT DOCUMENTS SHALL BE REFERRED TO MANN WILLIAMS FOR CLARIFICATION BEFORE WORK COMMENCES
 - ALL DIMENSIONS TO BE CHECKED AND VERIFIED BEFORE WORK COMMENCES
 - ONLY MATERIALS AND METHODS SPECIFIED SHOULD BE USED AND APPROVED BY MANN WILLIAMS BEFORE USE

SECTION 01A THROUGH ATTENUATION TANK TO NEW BUILDING - EXISTING
1:20

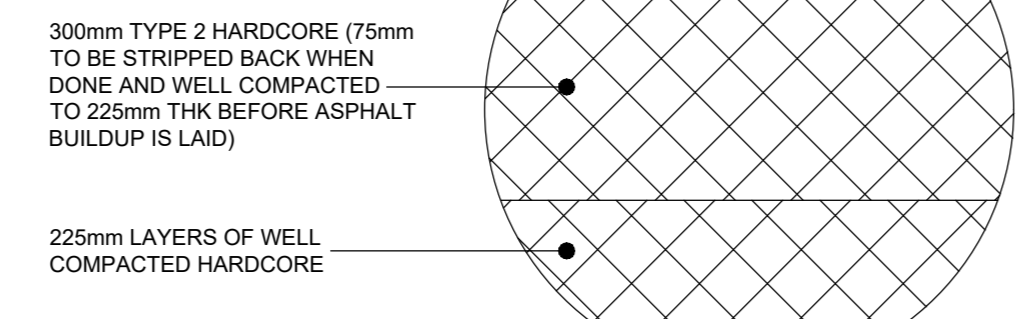

SECTION 01B THROUGH ATTENUATION TANK TO NEW BUILDING - SITE
1:20

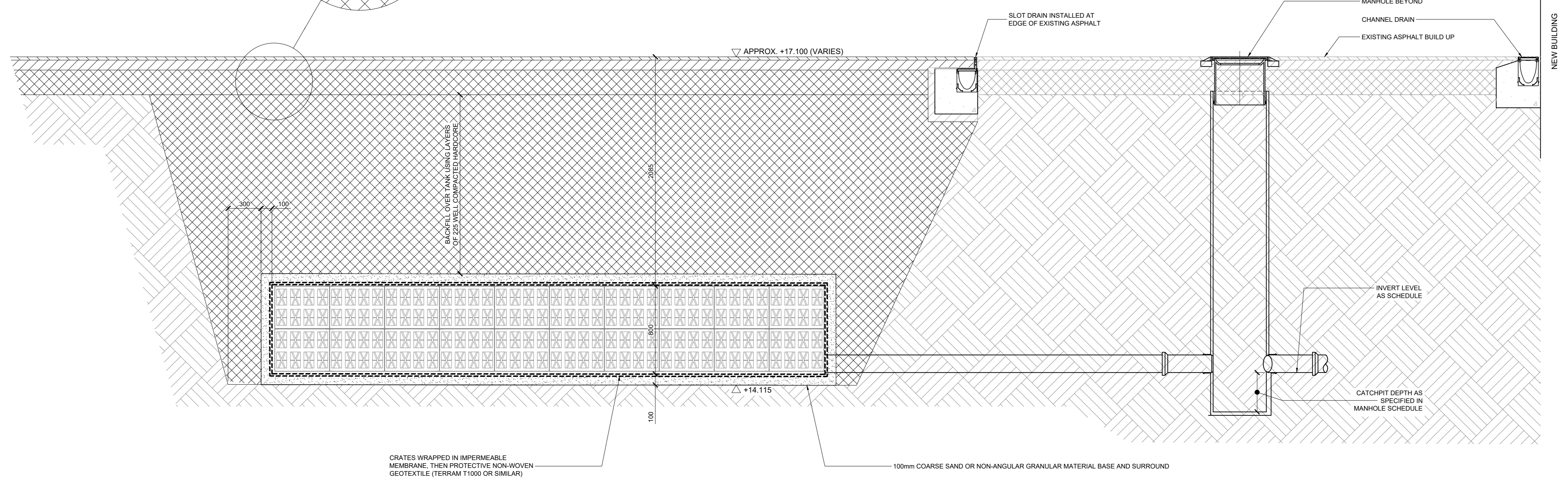
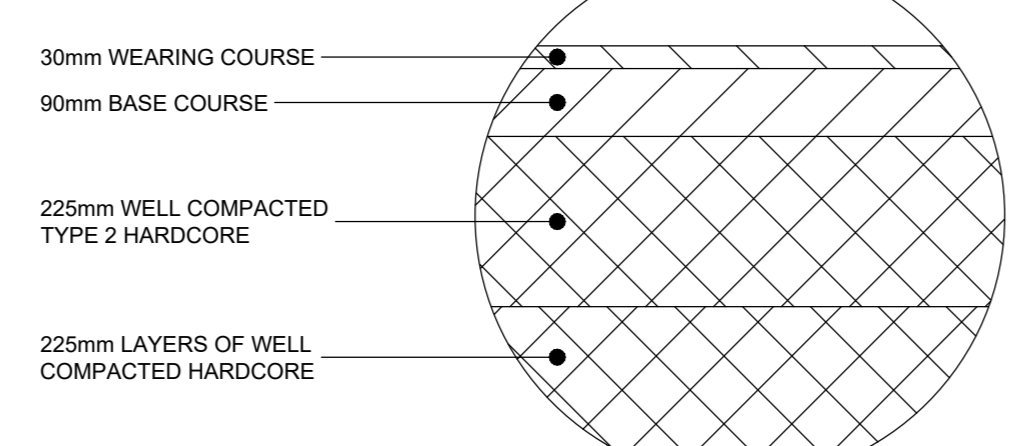

SECTION 01C THROUGH ATTENUATION TANK TO NEW BUILDING - COMPLETE
1:20

NO.	DESCRIPTION	BY	DATE
T1	TENDER ISSUE	JL	08.11.23

PROJECT
THE SHOEMAKERS MUSEUM
THE GRANGE

TYPE
DETAILS DRAINAGE
SHEET 2

MANN WILLIAMS CONSULTING CIVIL AND STRUCTURAL ENGINEERS 7 OLD KING STREET QUEN'S SQUARE BATH BA1 2JW T 01225 464419 E bath@mwmlliams.co.uk W www.mwmlliams.co.uk	
DATE: 08.11.23	NOV 2023 11439

NO.	DATE	BY	ROLE	OPERATION
XX	XX	DR	D	MNW
GRA	0552	T1		