

REFUSE & STORAGE FRONT ELEVATION

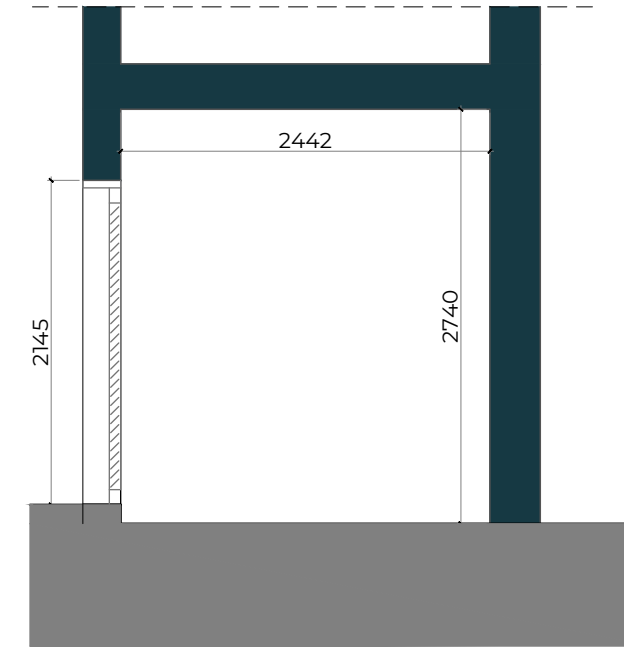

REFUSE & STORAGE SECTION



REFUSE & CYCLE STORAGE DOOR REFERENCE
- STEEL DOORS WITH LOUVERS & SAFETY LOCK



CYCLE STORAGE REFERENCE
- SHEFFIELD STANDS FOR No.8 CYCLES

- CYCLE STORE**
- 4x Sheffield Stands for no.8 Cycles
- RESIDENTIAL BIN STORE**
- 1100 I Bins for Refuse
- 1100 I Bins for Recycling
- COMMERCIAL BIN STORE**

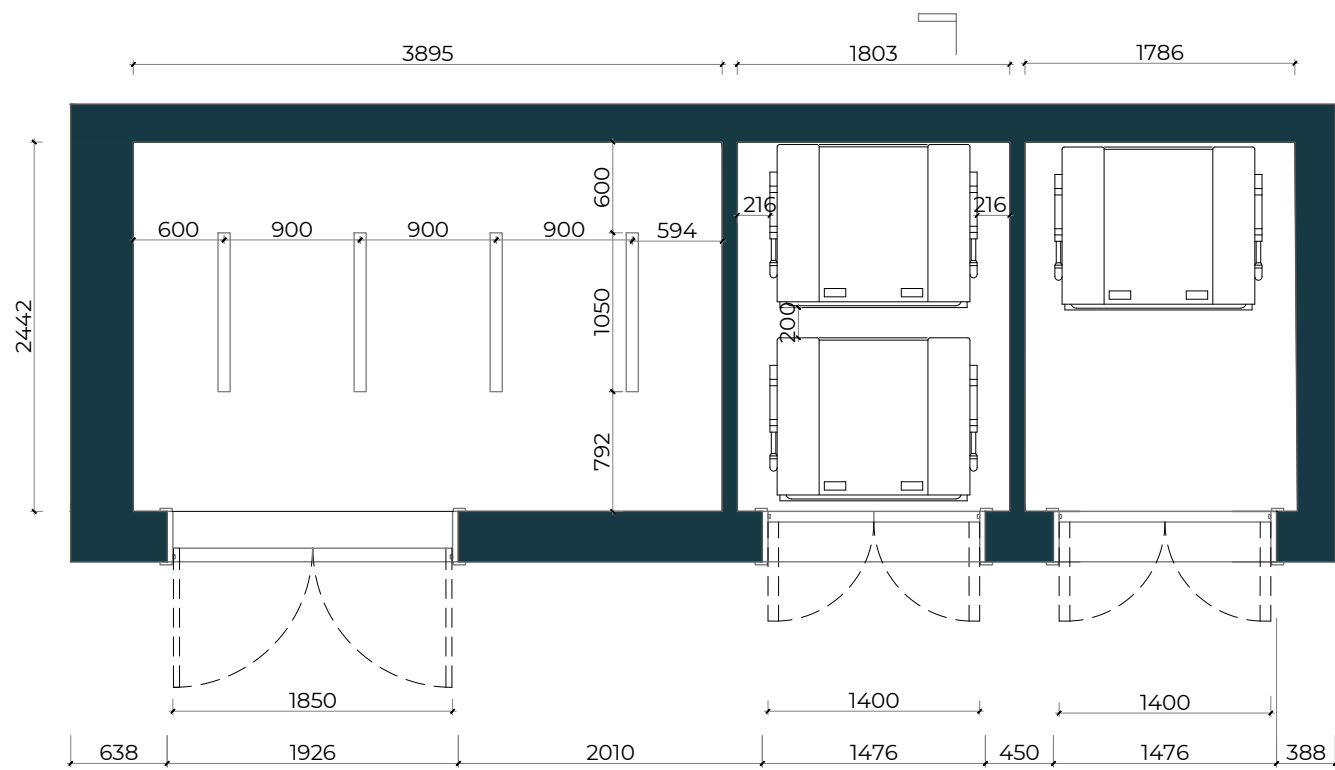

REFUSE & STORAGE FLOOR PLAN

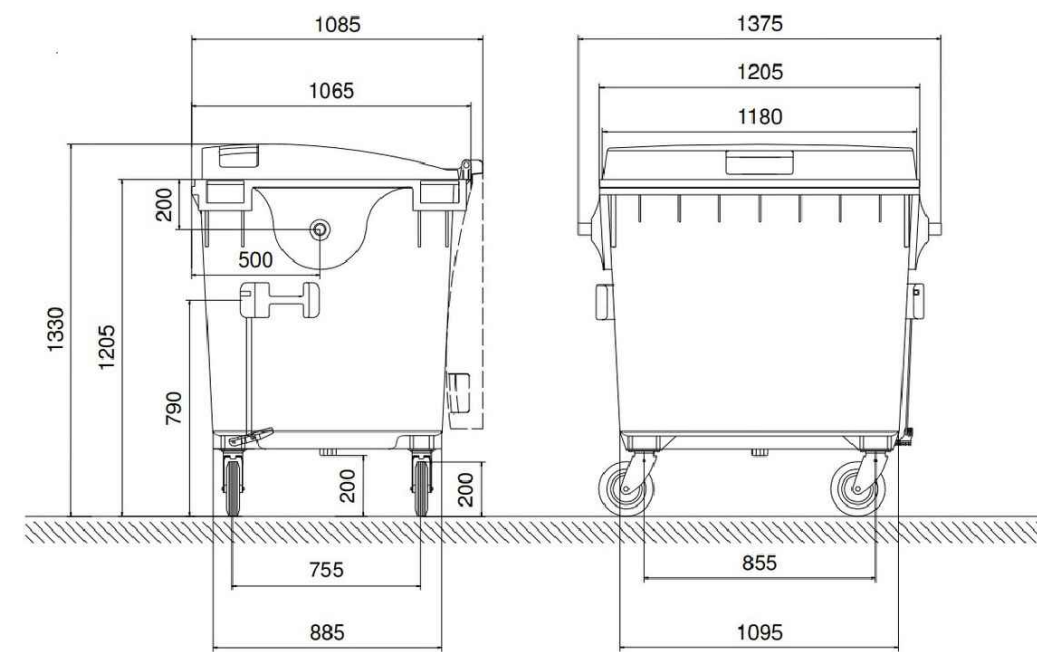

1100 I BIN DIMENSIONS

Rev No.	Date	Description
---------	------	-------------

Notes:
Any inaccuracies or errors to be reported to the architect/surveyor immediately and prior to any work commencing. All dimensions to be verified on site. All work to comply with British Standards Code of practice. All external surfaces and materials to match existing. This drawing and all information provided within it is the copyright of UPP Consultants Ltd. and reproduction without prior consent is strictly forbidden.

Dwg No	141-143DH-A-20-101	Drawn	DR
Scale	1:50 @ A3	Checked	UPP
Issue Date	23.11.2023		
Project Address	141-143 Dollis Road, London, NW7 1JX		
Client	Purple Fox Enterprises Ltd	Status	For Planning